

Peter, please make each next START diff. lines 0.5cm longer then the former ones. e.g. if A\_START and A\_STARTb have 35 mm then B\_START and B\_STARTb should have 40mm

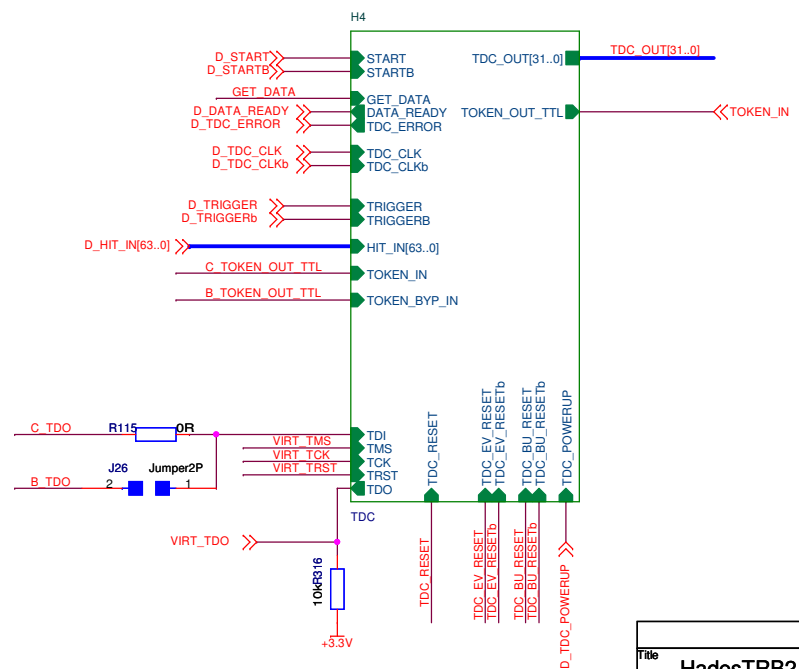

Title		
HadesTRB2 - TIME		
Size	Document Number	Rev
A3	<Doc>	<RevCode>
Date:	Tuesday, November 07, 2006	Sheet 2 of 22

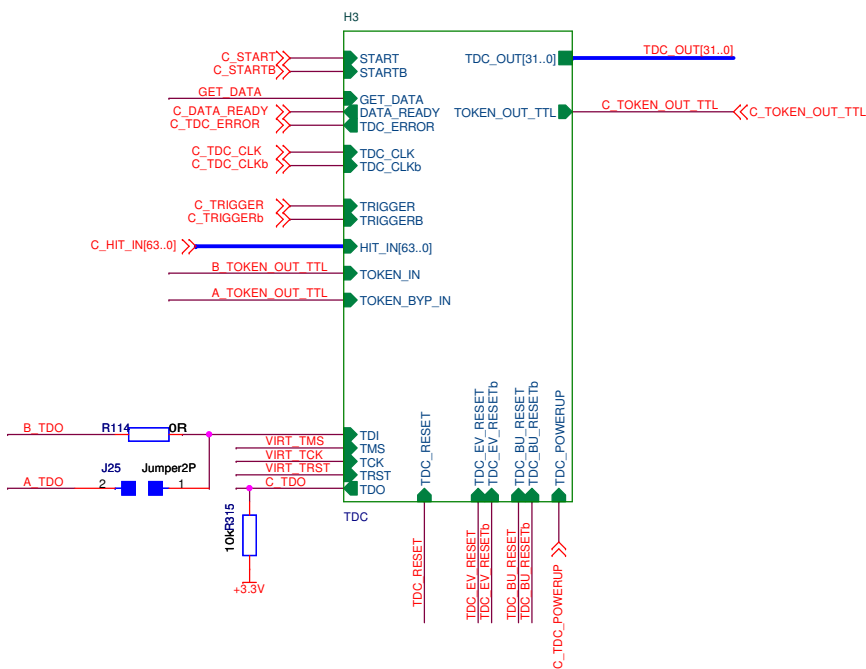

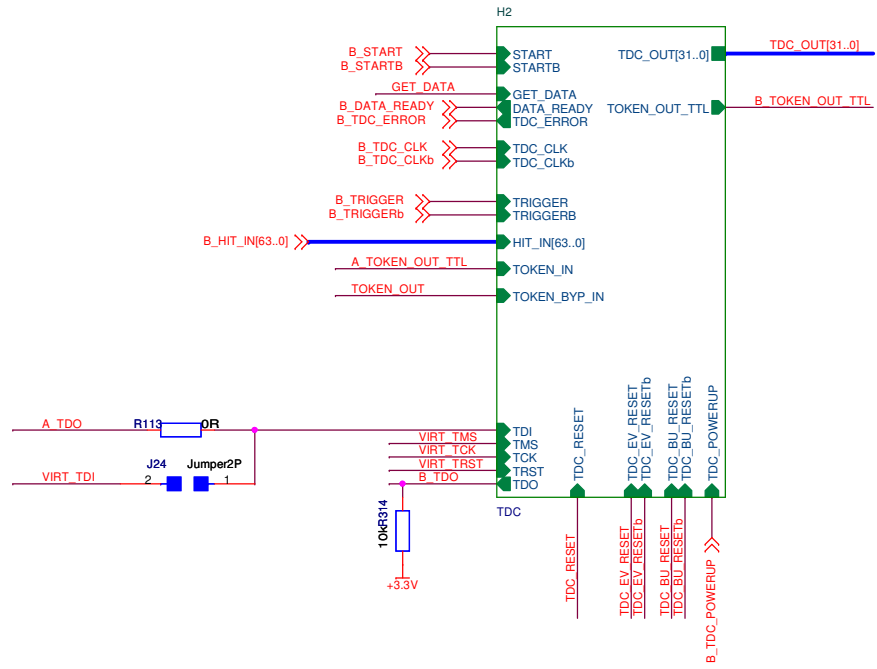
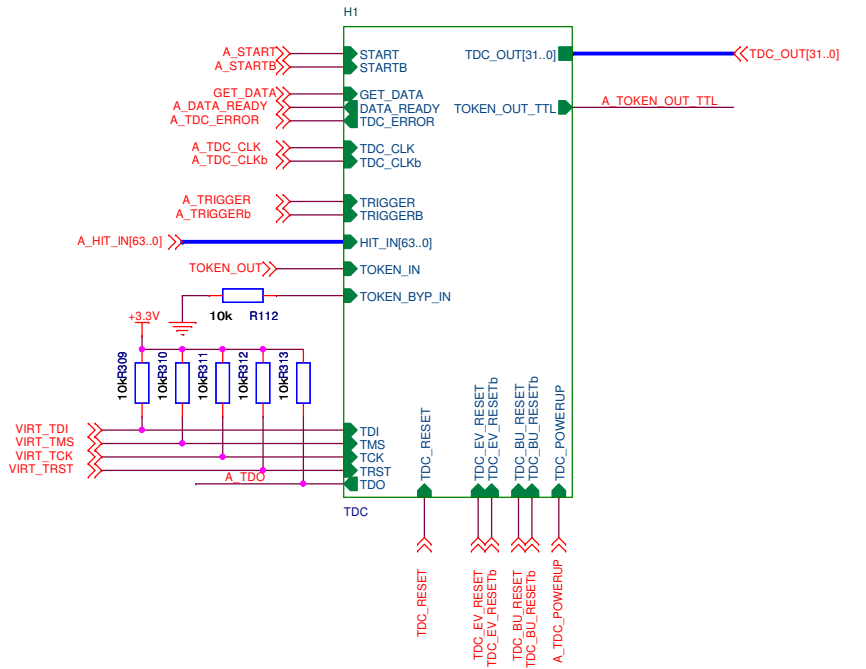
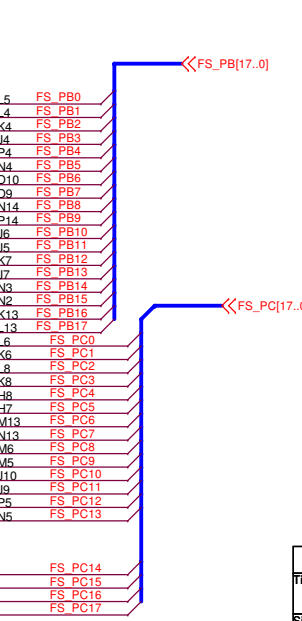
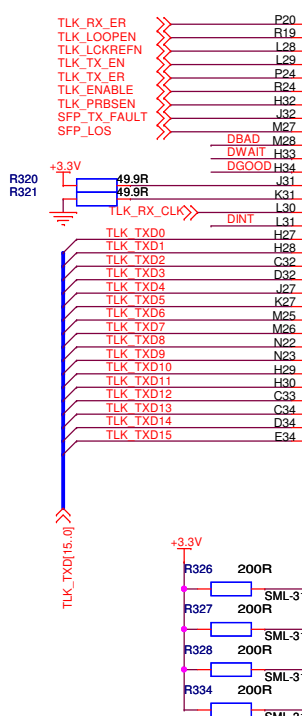
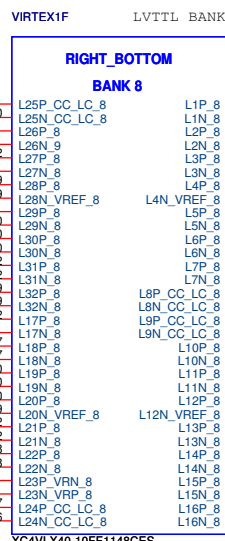
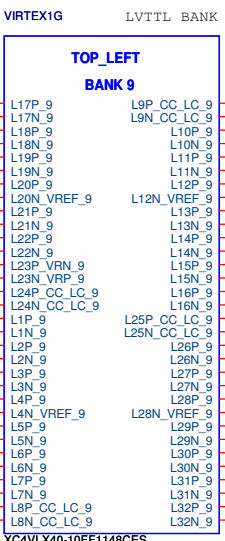
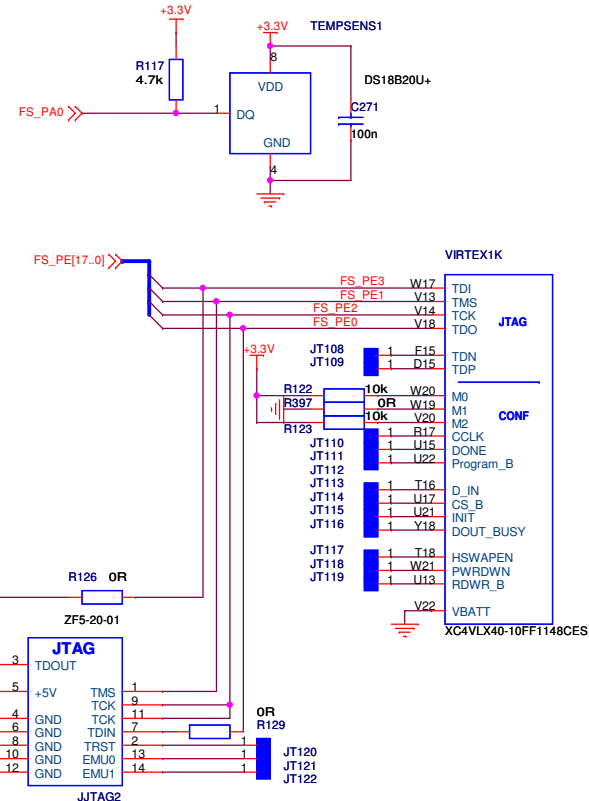
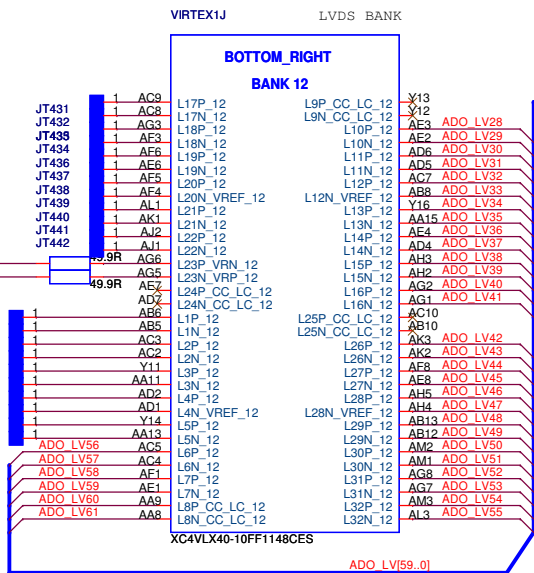
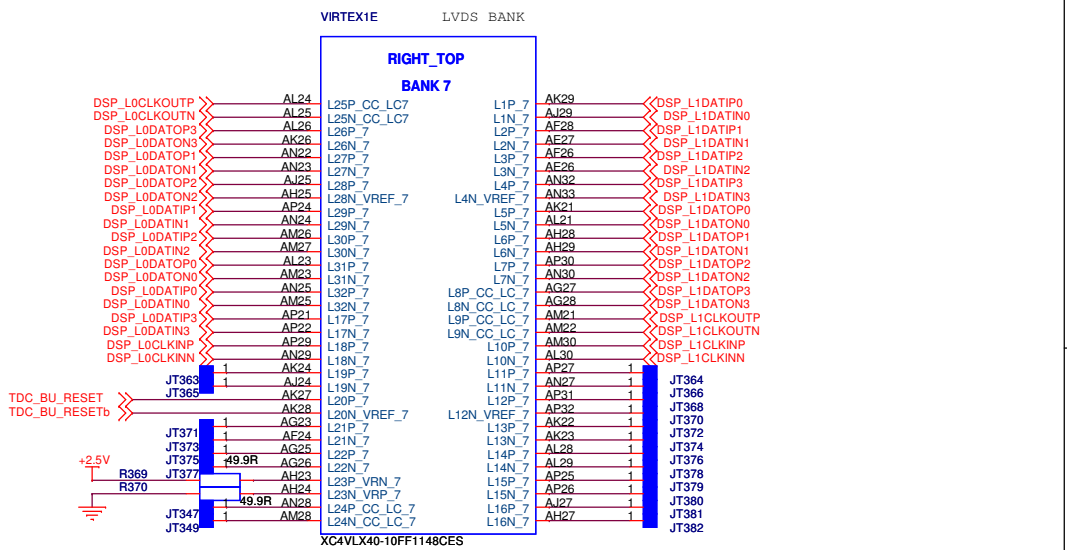
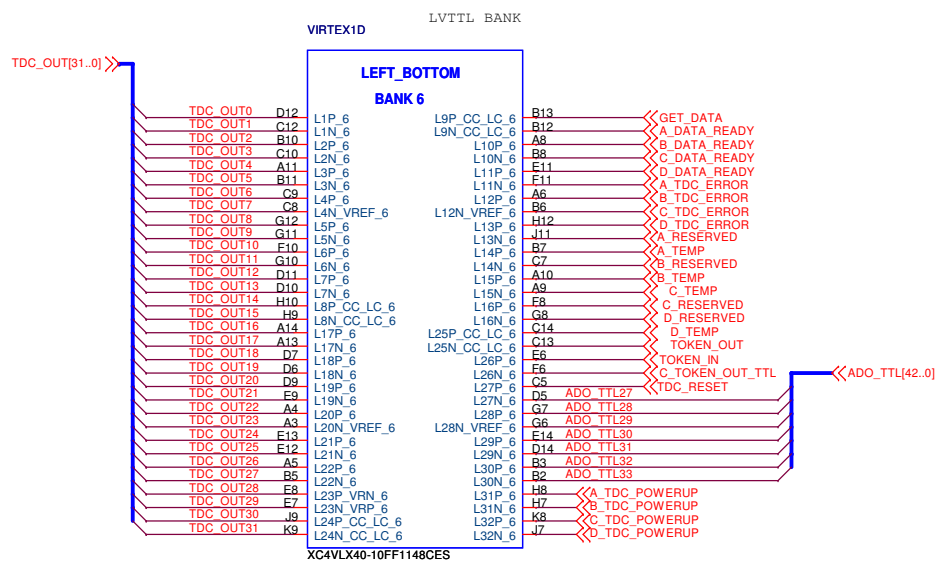
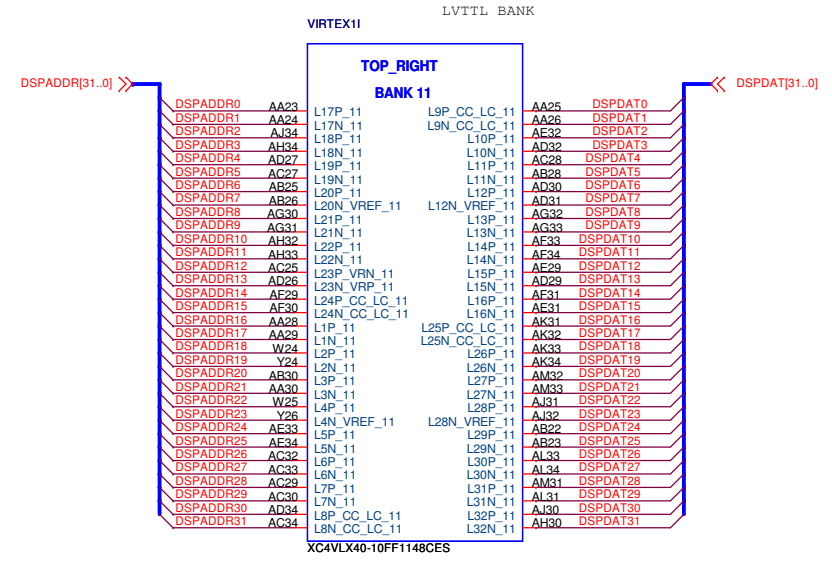
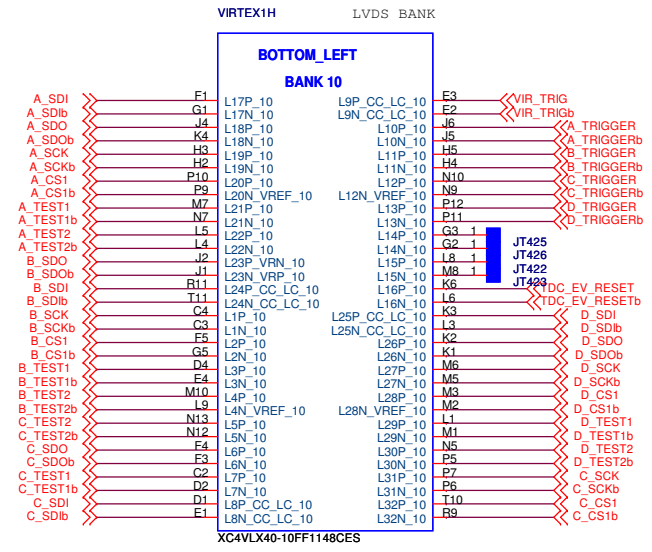

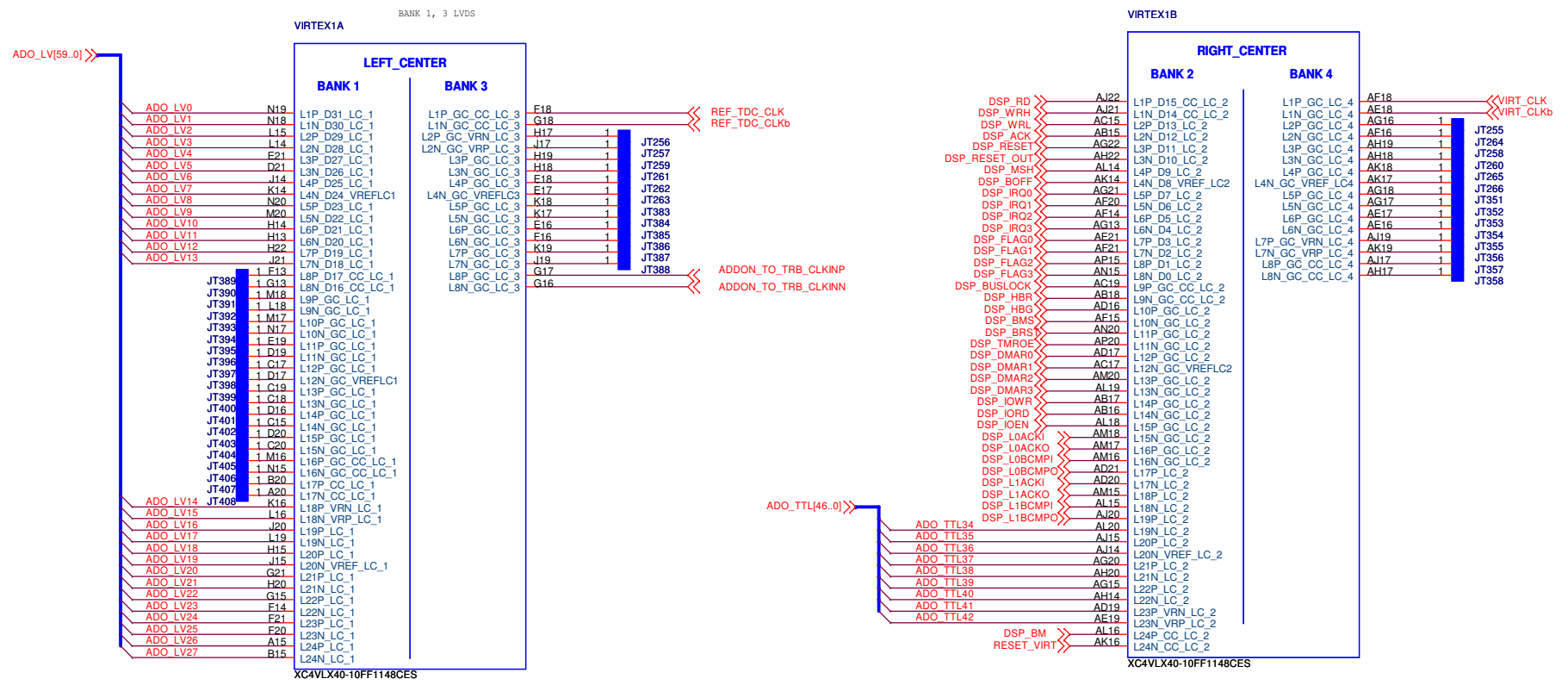

DSP control - banks 2, 7, 11

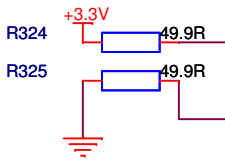
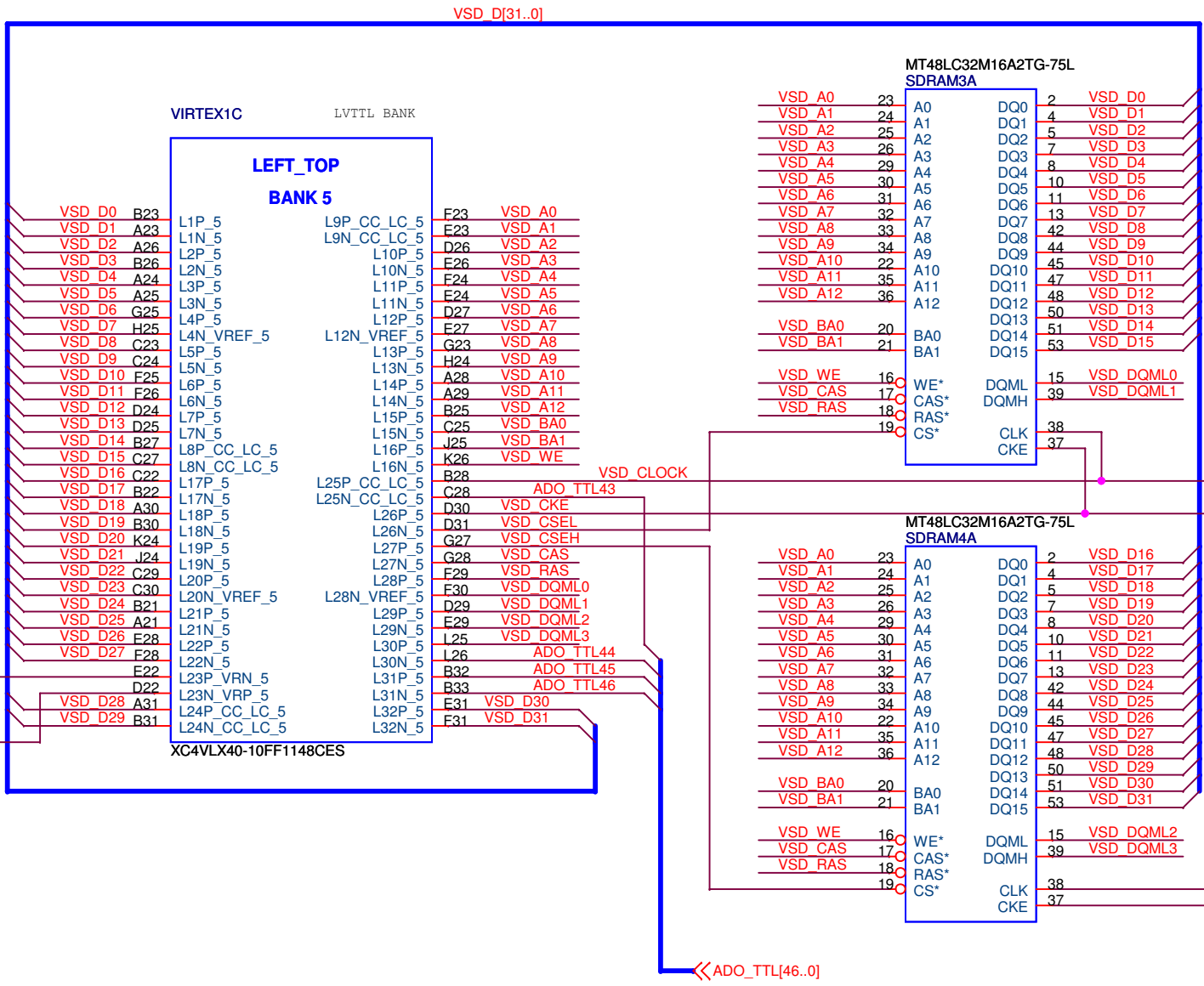

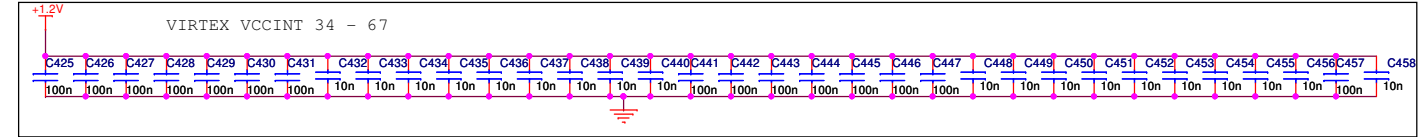
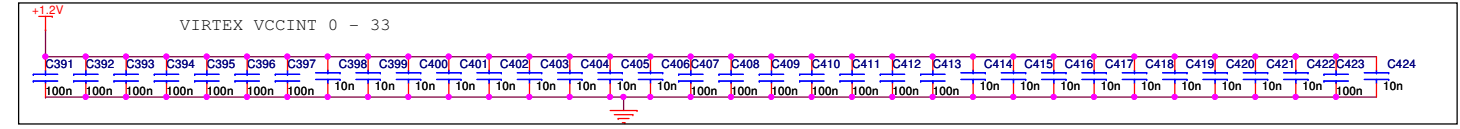
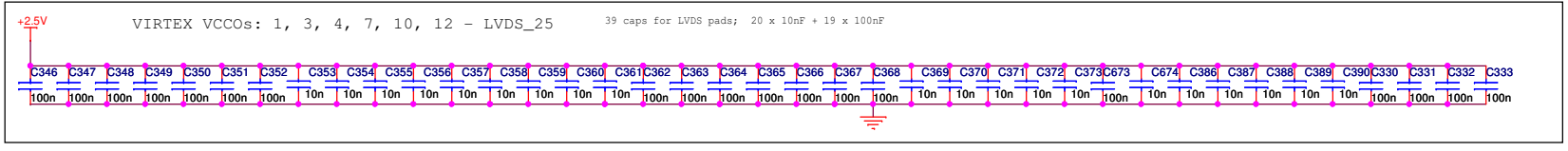
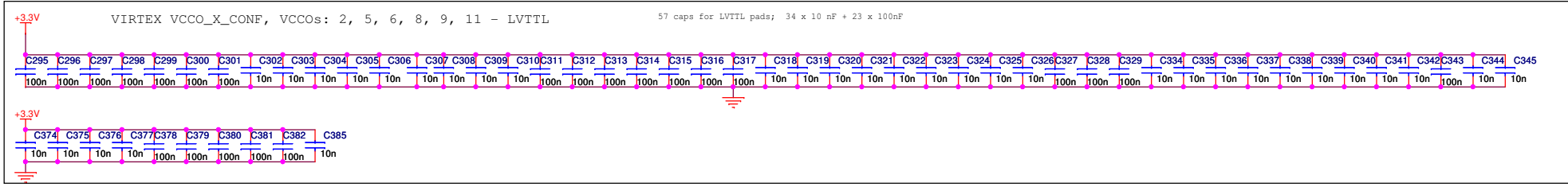
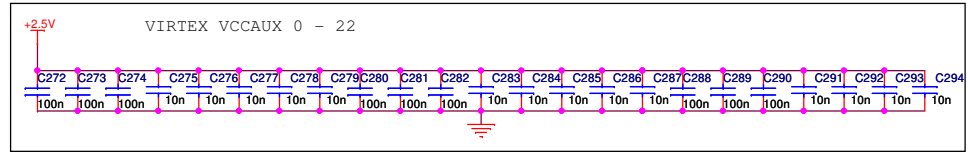
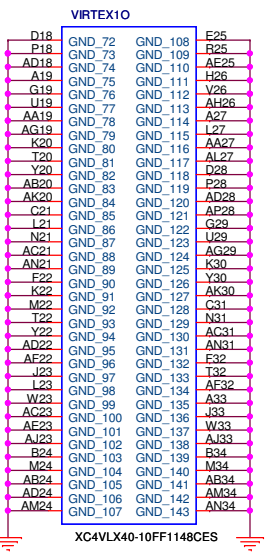
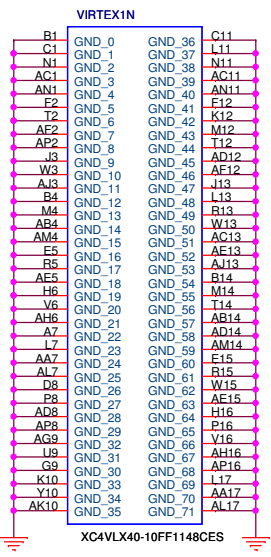
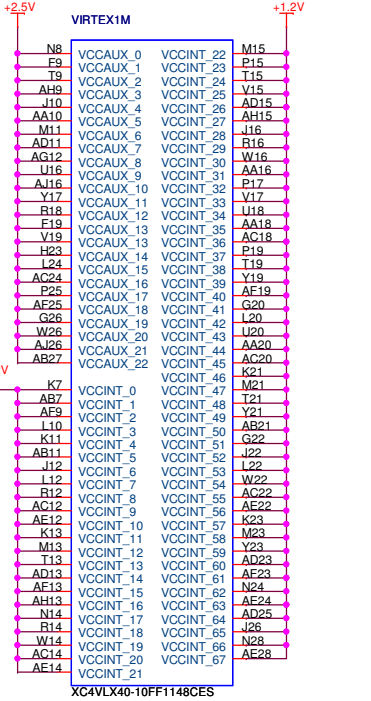
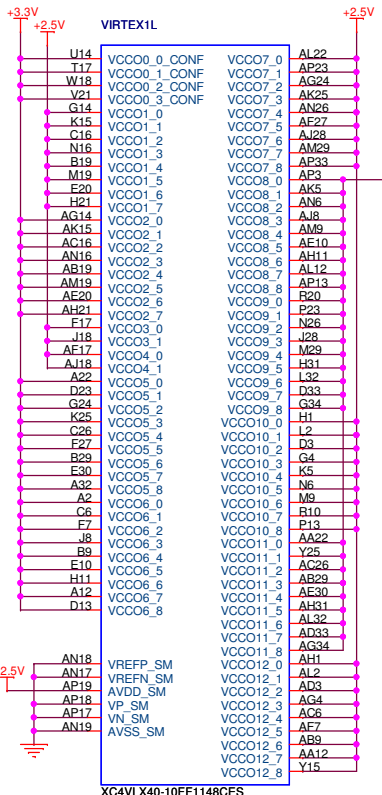

Title			HadesTRB2 - VIRTEX SUPPLY		
Size	Document Number				Rev
A3	<Doc>				<Rev Code>
Date:	Tuesday, November 07, 2006	Sheet	7	of	22



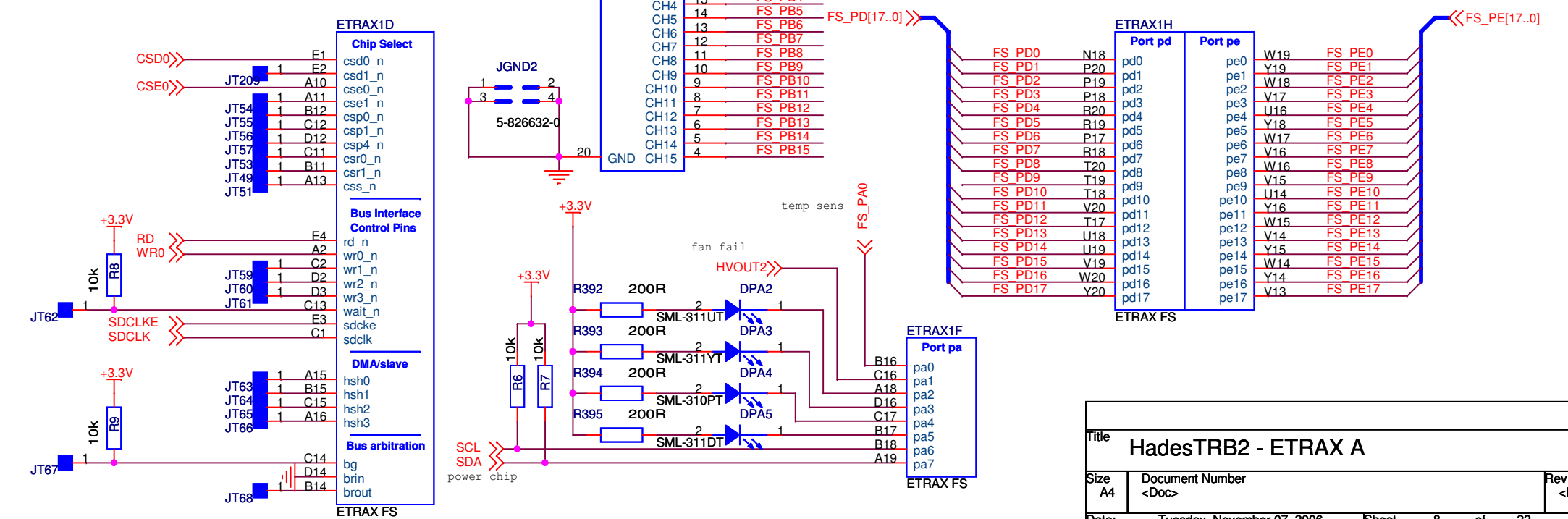
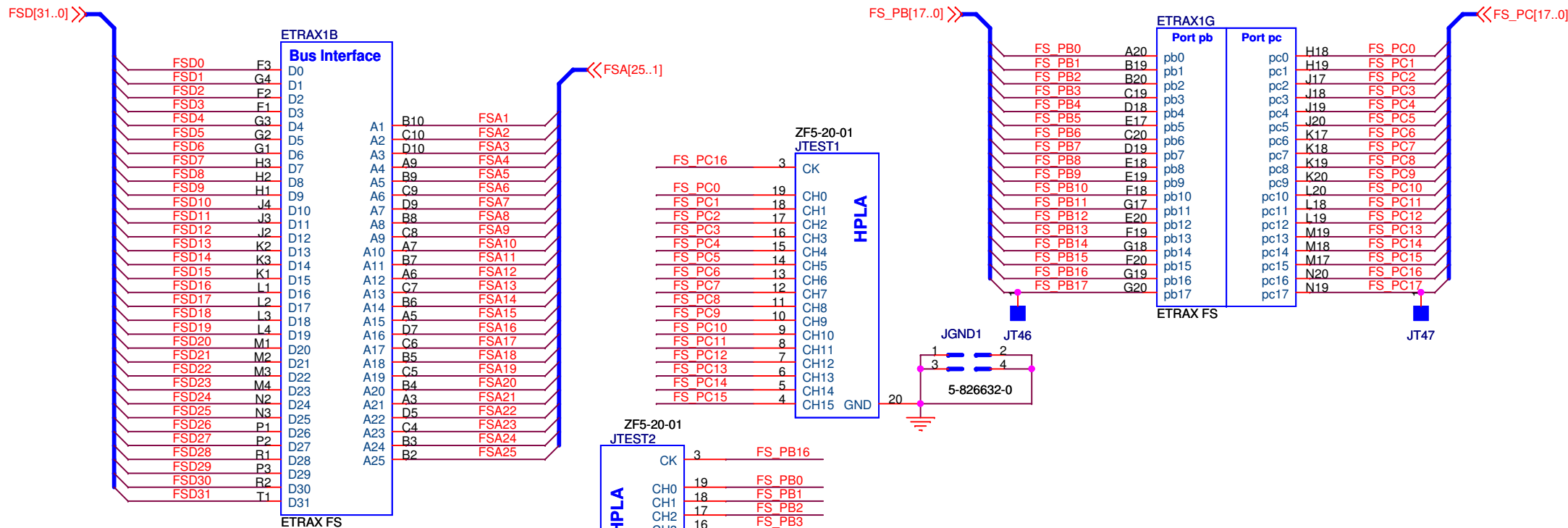



Place the termination network and RJ45 connector close to the BCM5221

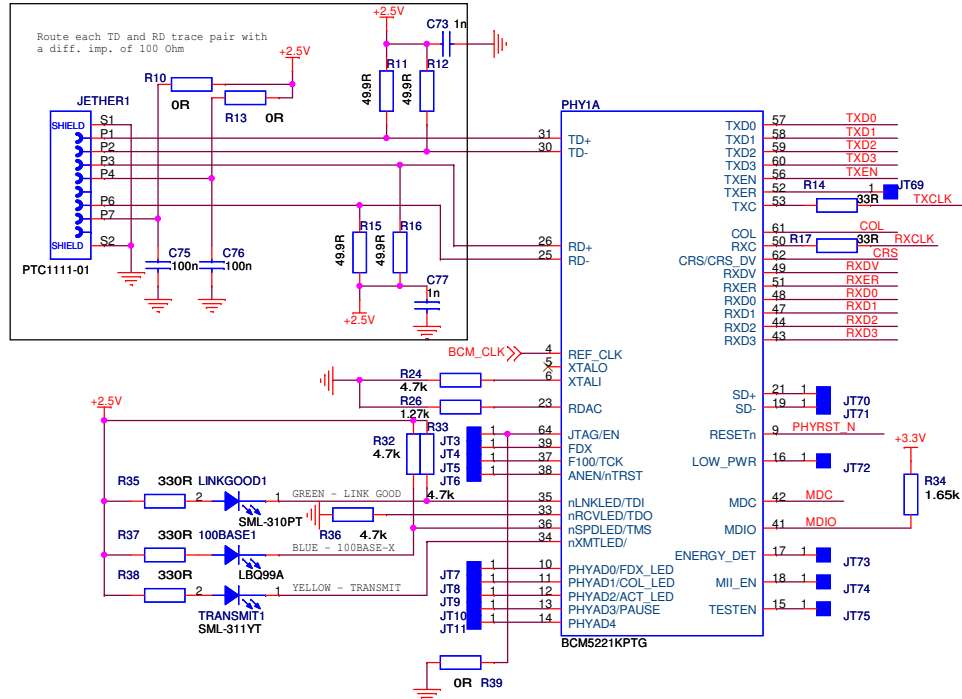

BS3	BS2	BS1	BS0	
-	0	0	1	NOR Flash
-	0	0	1	Network RX only
-	0	1	0	Network RX/TX
-	0	1	1	NAND Flash
-	1	0	0	Serial
-	1	0	1	Master boot
-	1	1	0	Slave boot
-	1	1	1	No boot
0	-	-	-	Ethernet Halv-Duplex
1	-	-	-	Ethernet Full-Duplex

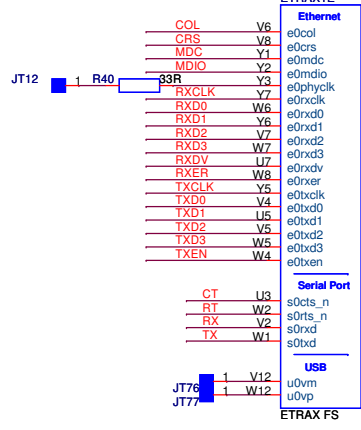
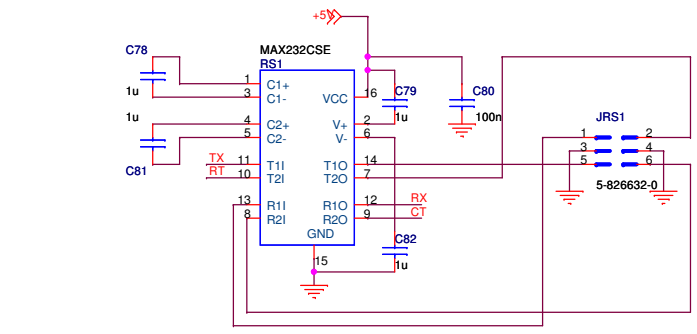
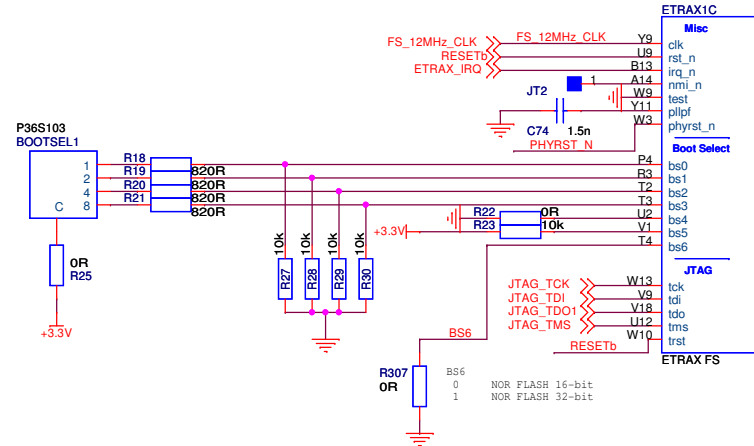

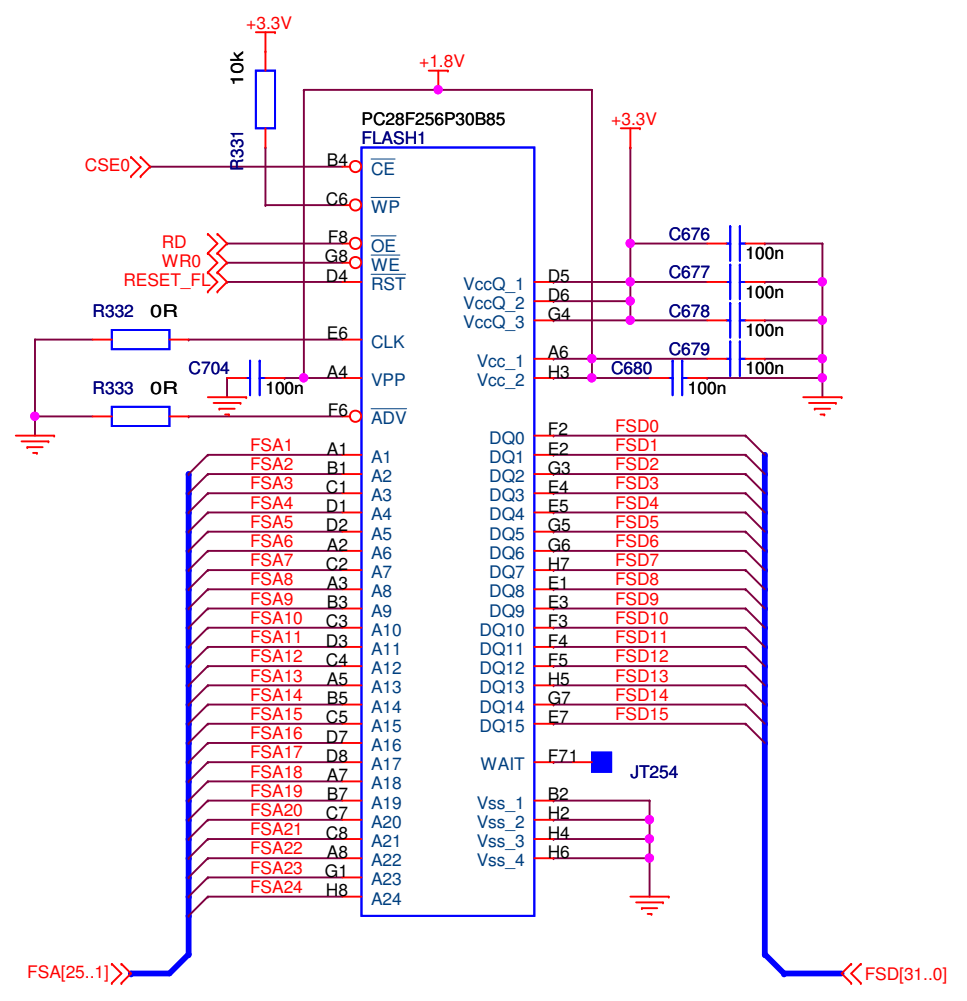

Title		
HadesTRB2 - FLASH MEMORY		
Size	Document Number	Rev
A4	<Doc>	<Rev C>
Date:	Tuesday, November 07, 2006	Sheet 10 of 22

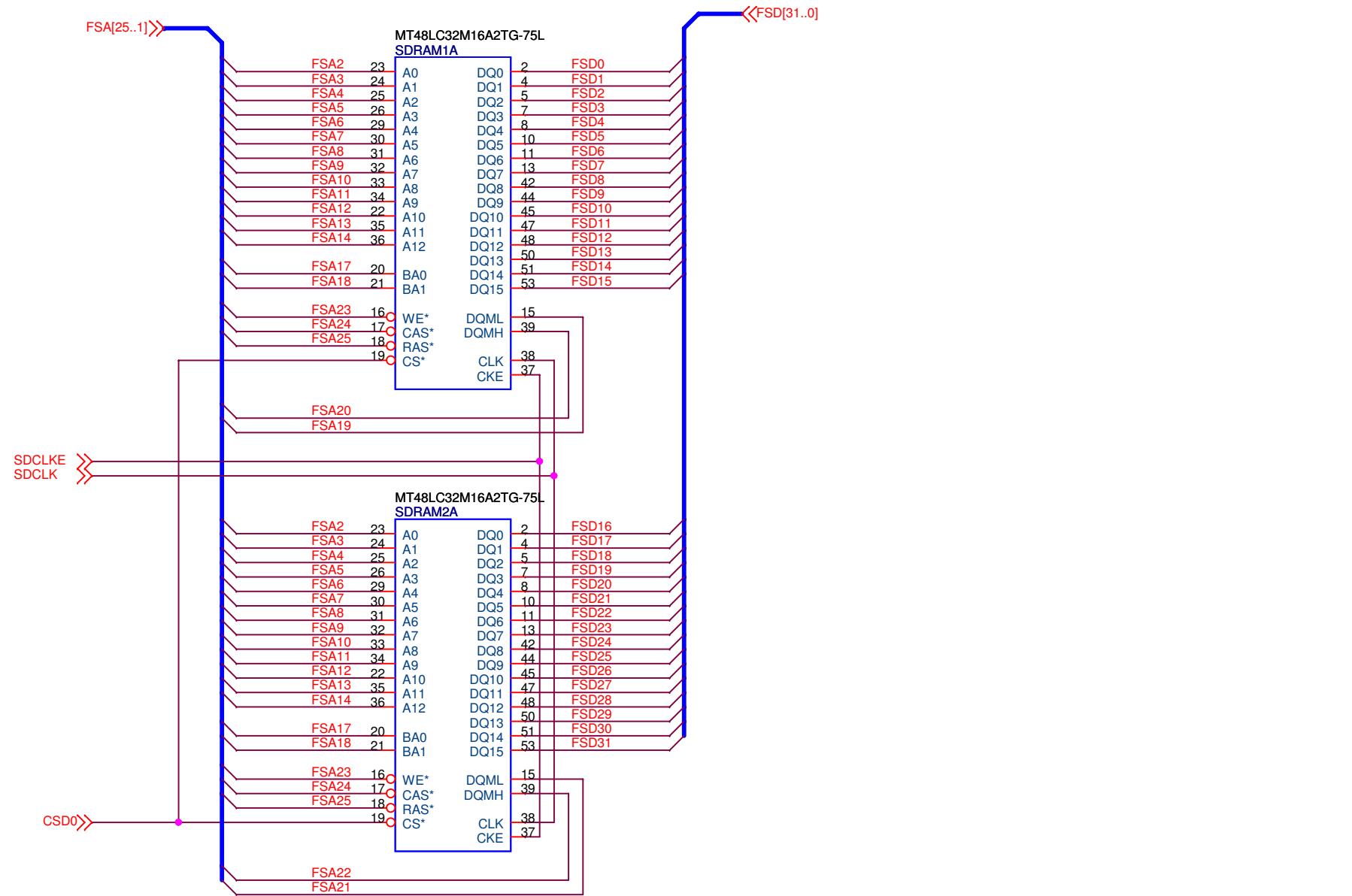

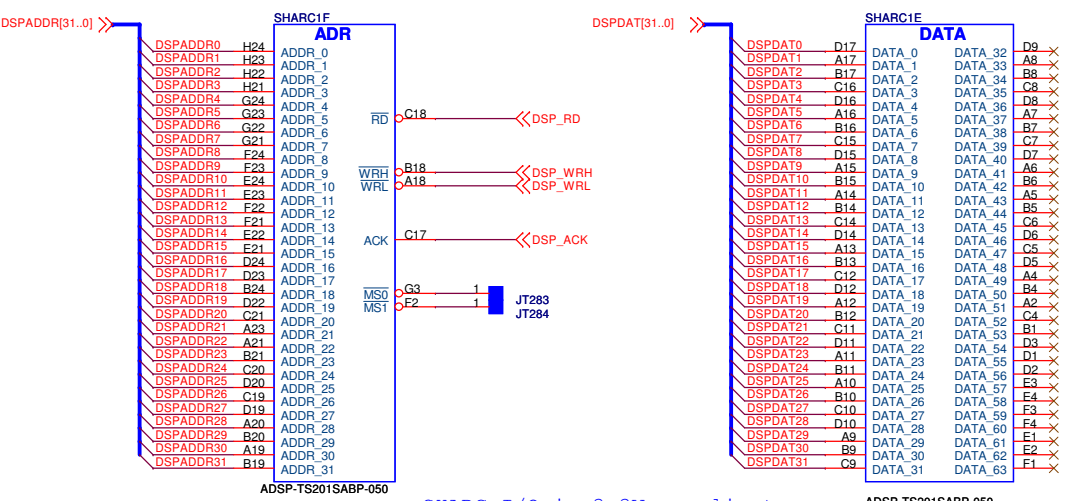

SHARC I/O is 3.3V compliant

Routing:  
 order should be: DAT0, DAT1, CLK, DAT2, DAT3,  
 no via in between those signals,  
 only 45° turns (no 90°),  
 length should be matched for one direction and one port  
 (they are full duplex)  
 Peter, please read EE-179 System Design Guidelines.

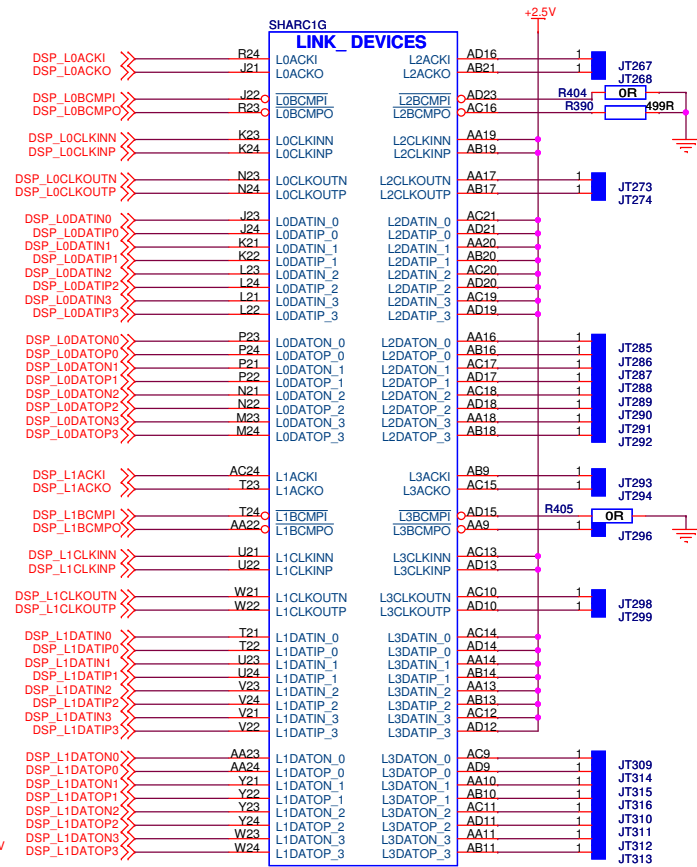

DS - drive strength  
 default 101

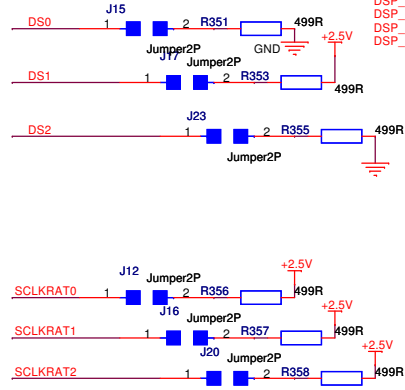

Signal	Ratio	Frequency
SCLKRAT[2..0]	ratio (CCLK=ratio * SCLK)	
0 0 0 (default)	4	CCLK = 600 MHz
0 1 0	6	CCLK = 500 MHz

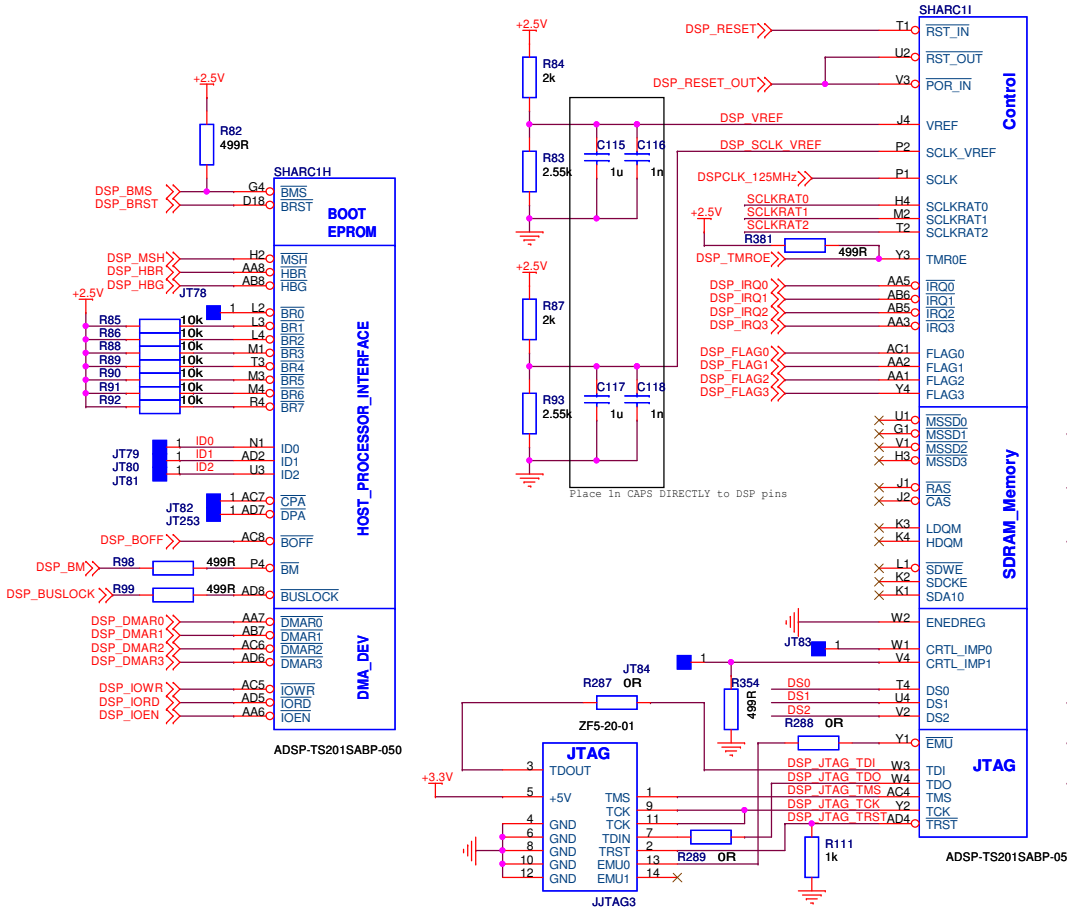



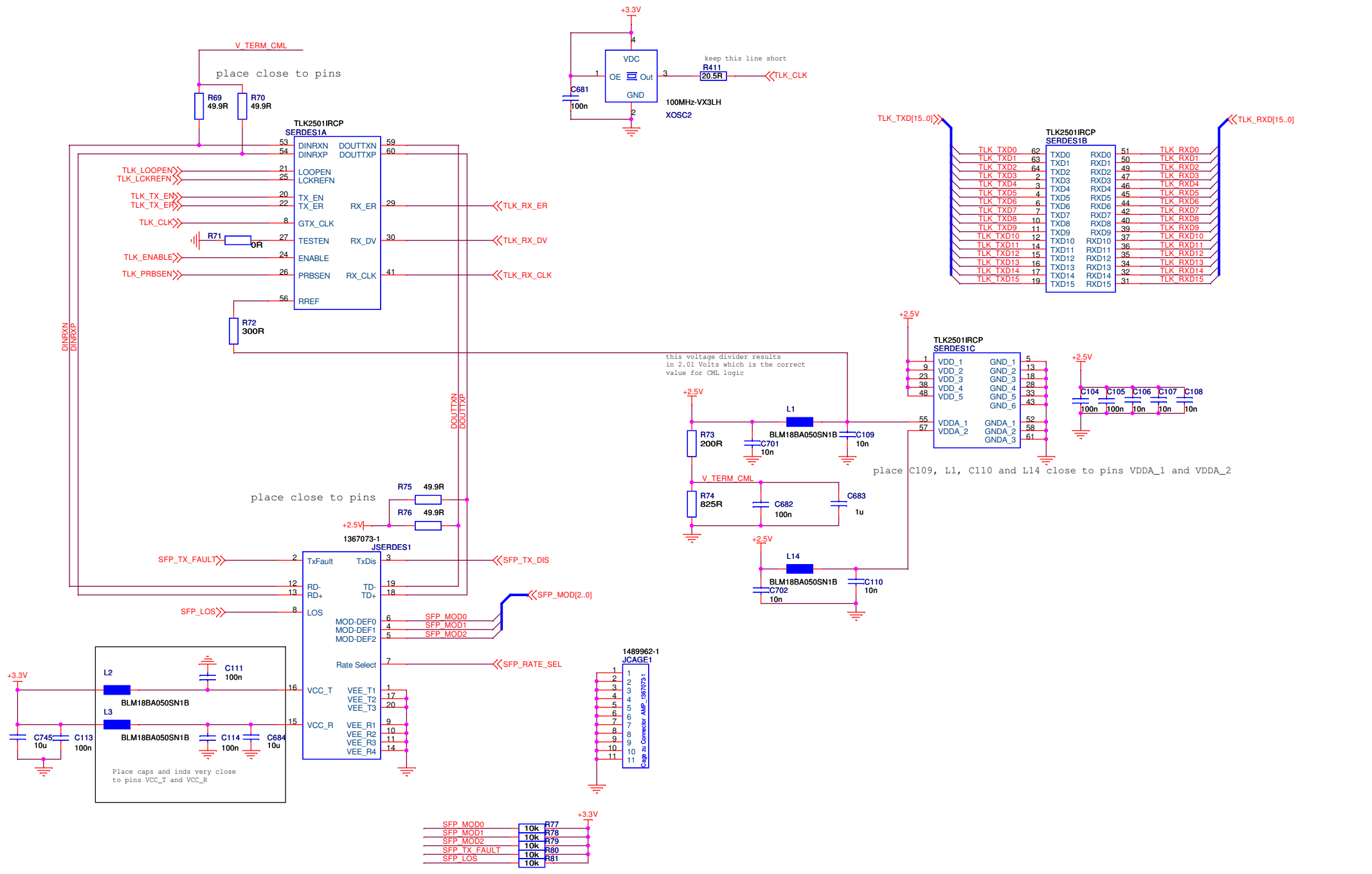

MODDEF0 is grounded by module when inserted

Title		
<b>HadesTRB2 - SERDES</b>		
Size	Document Number	Rev
A3	<Doc>	<Rev Code>
Date:	Tuesday, November 07, 2006	Sheet 14 of 22

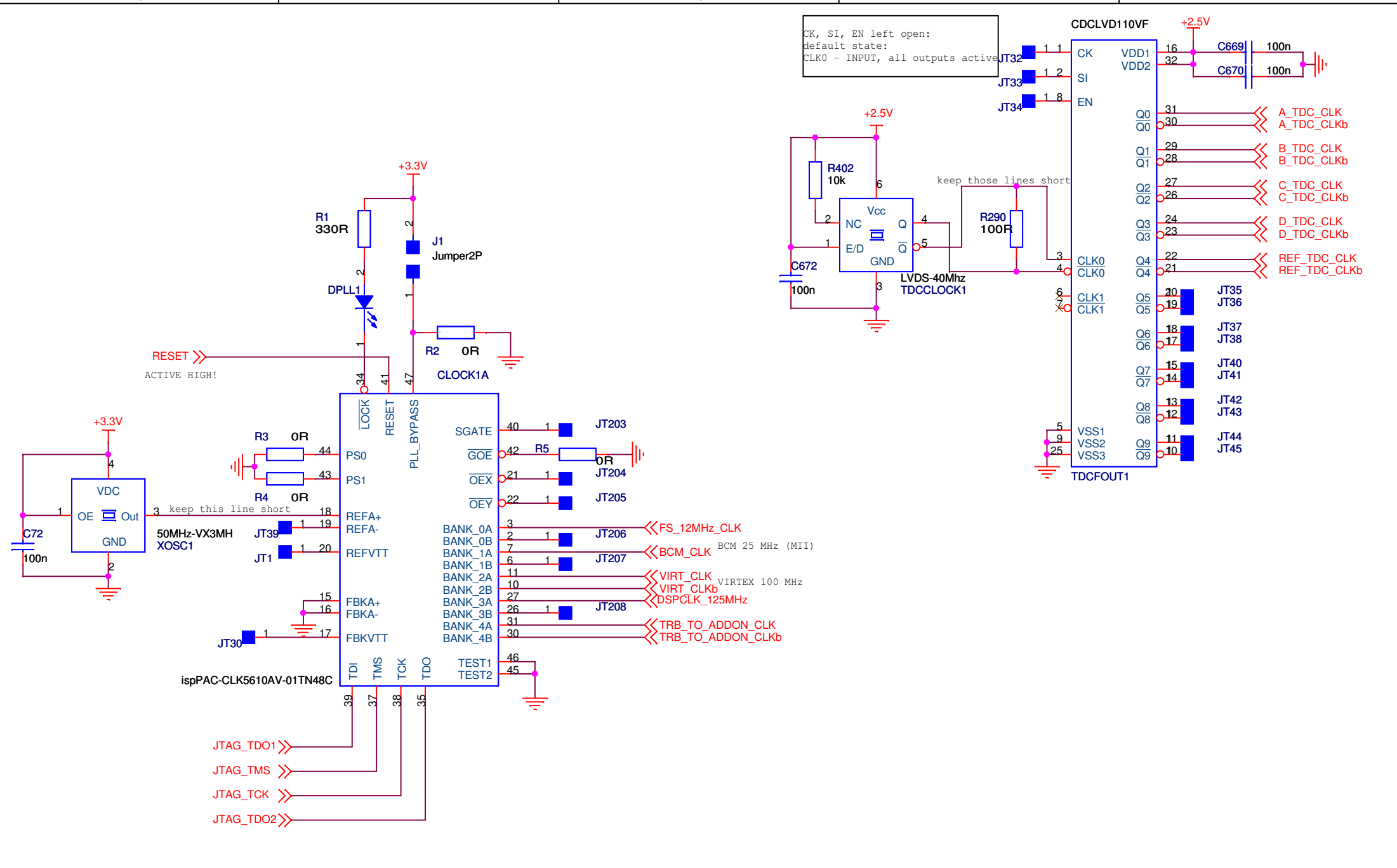



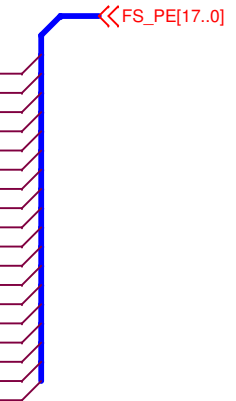
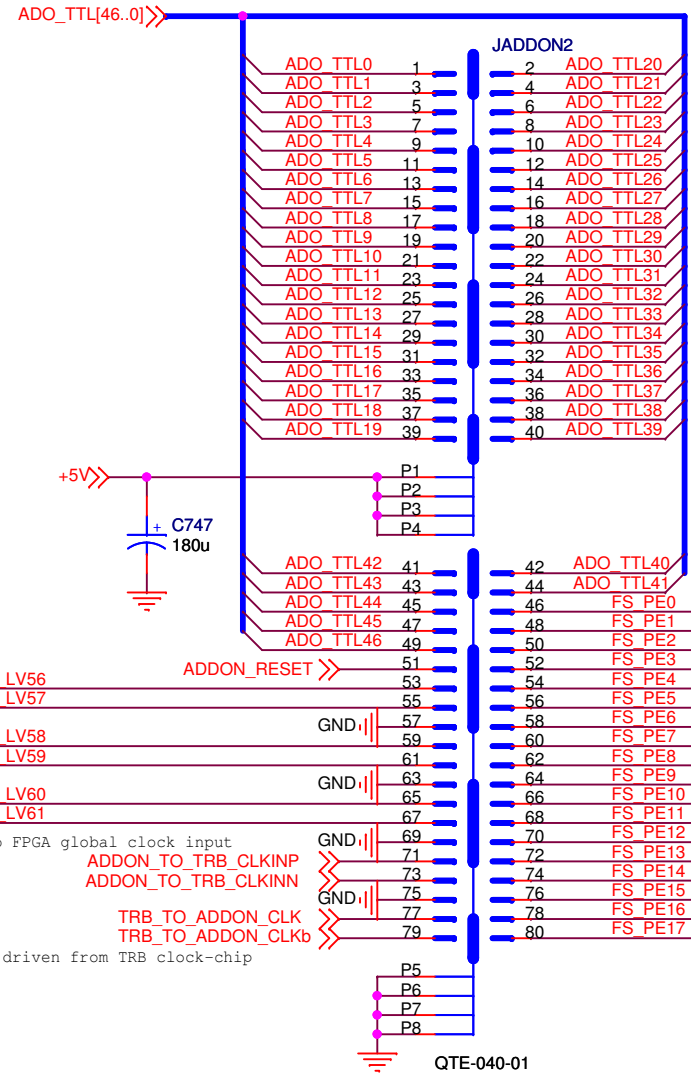
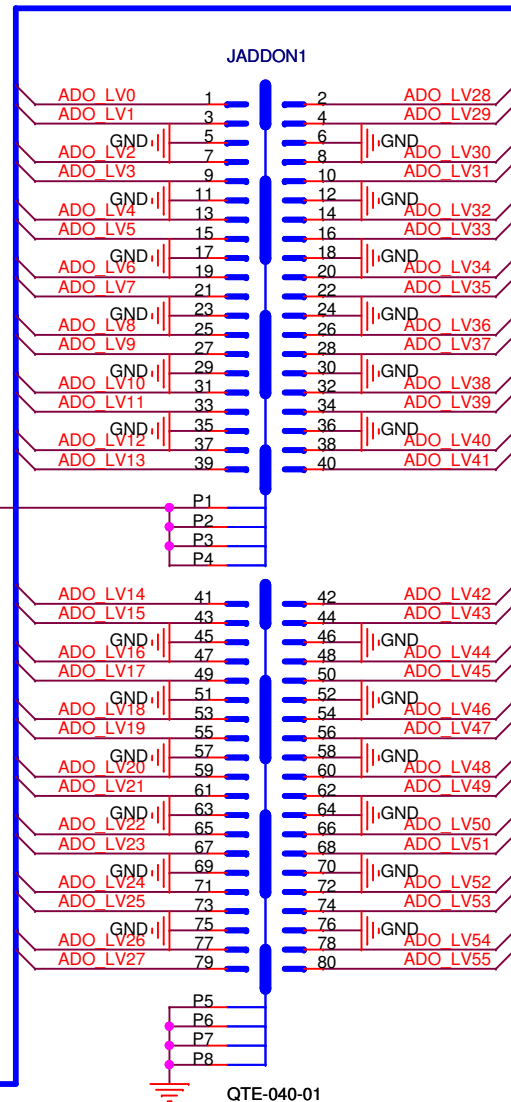
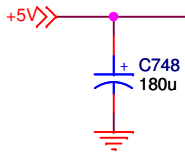
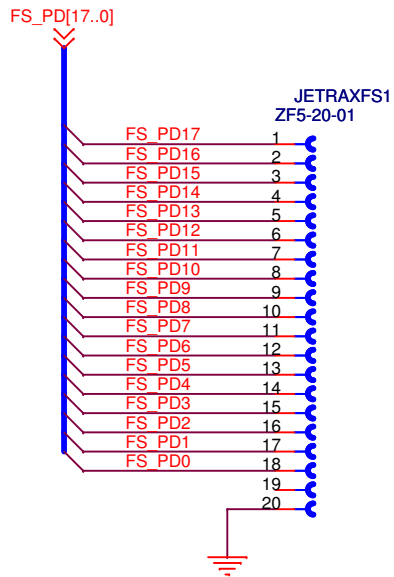

Title		
HadesTRB2 - CONNECTORS		
Size	Document Number	Rev
A4	<Doc>	<Rev C>
Date:	Tuesday, November 07, 2006	Sheet 16 of 22

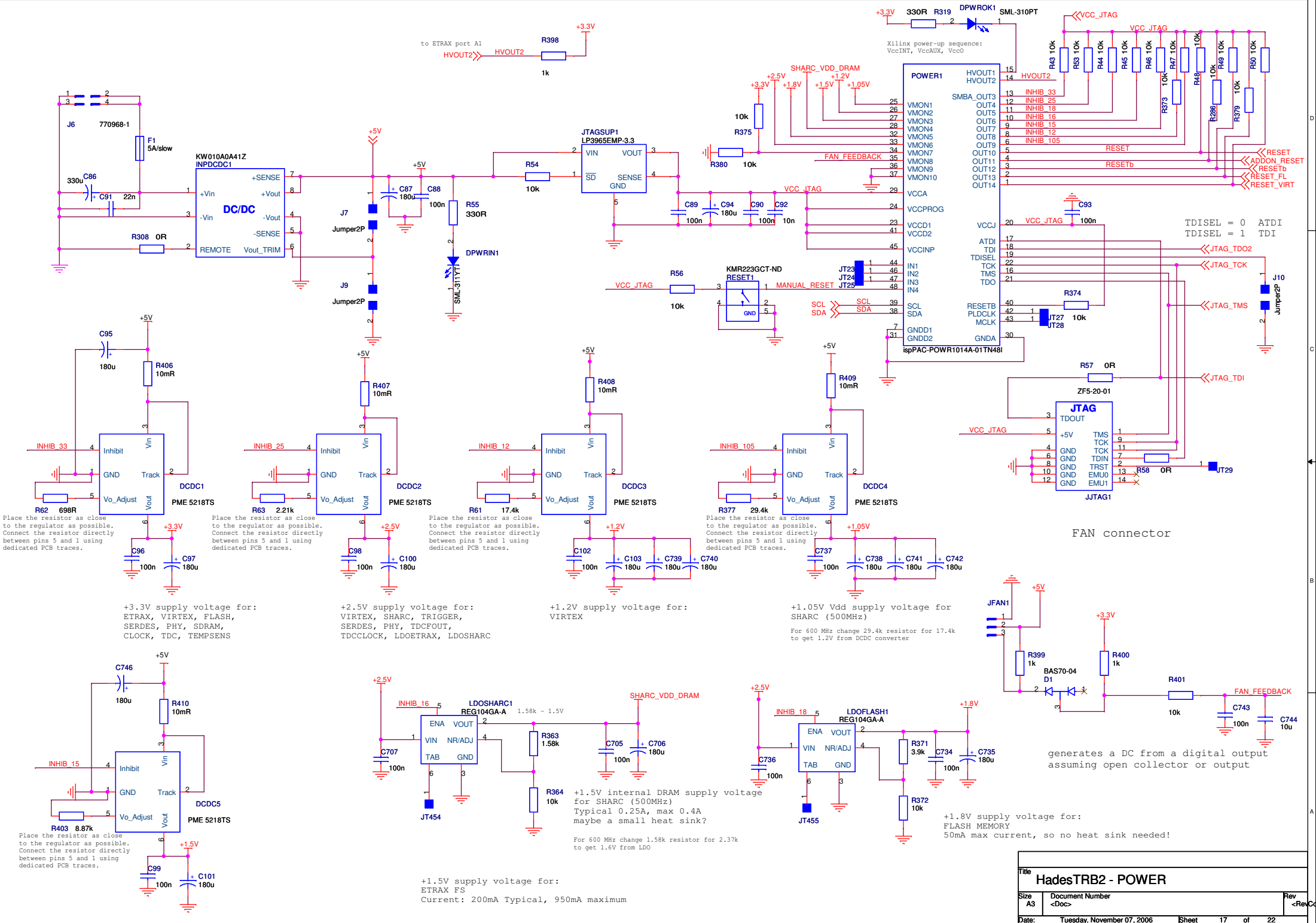

Title		
HadesTRB2 - POWER		
Size	Document Number	Rev
A3	<Doc>	<Rev Code>
Date:	Tuesday, November 07, 2006	Sheet 17 of 22

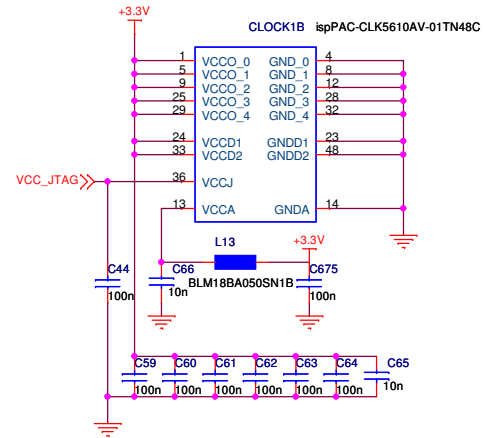
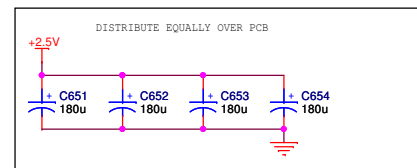
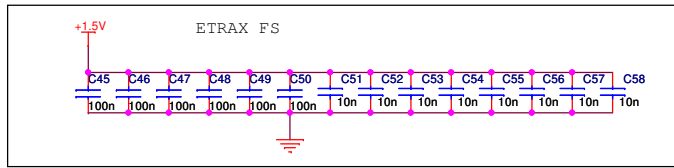
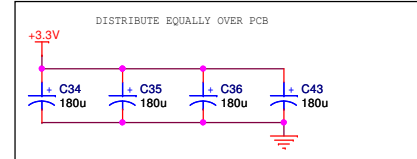
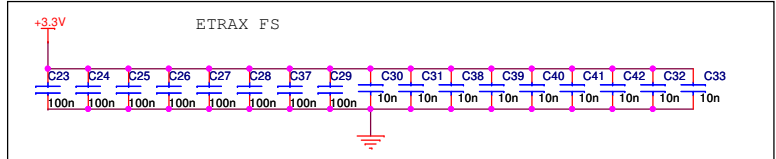
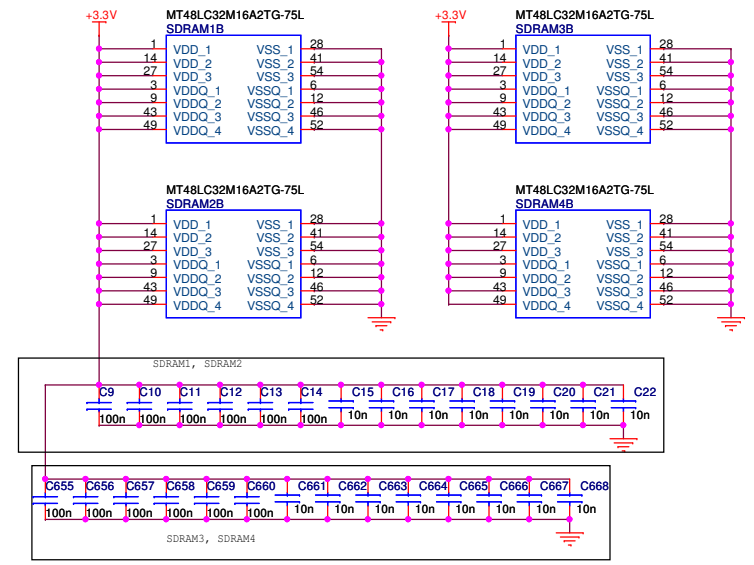
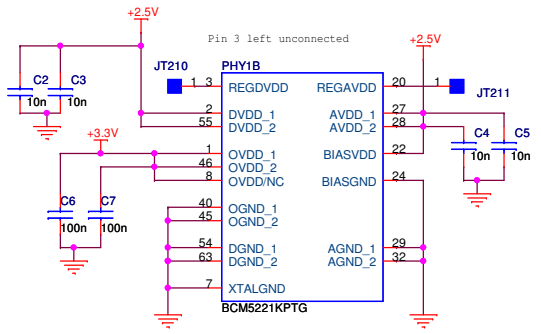
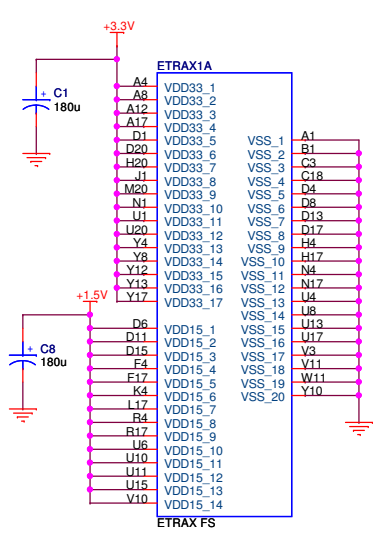

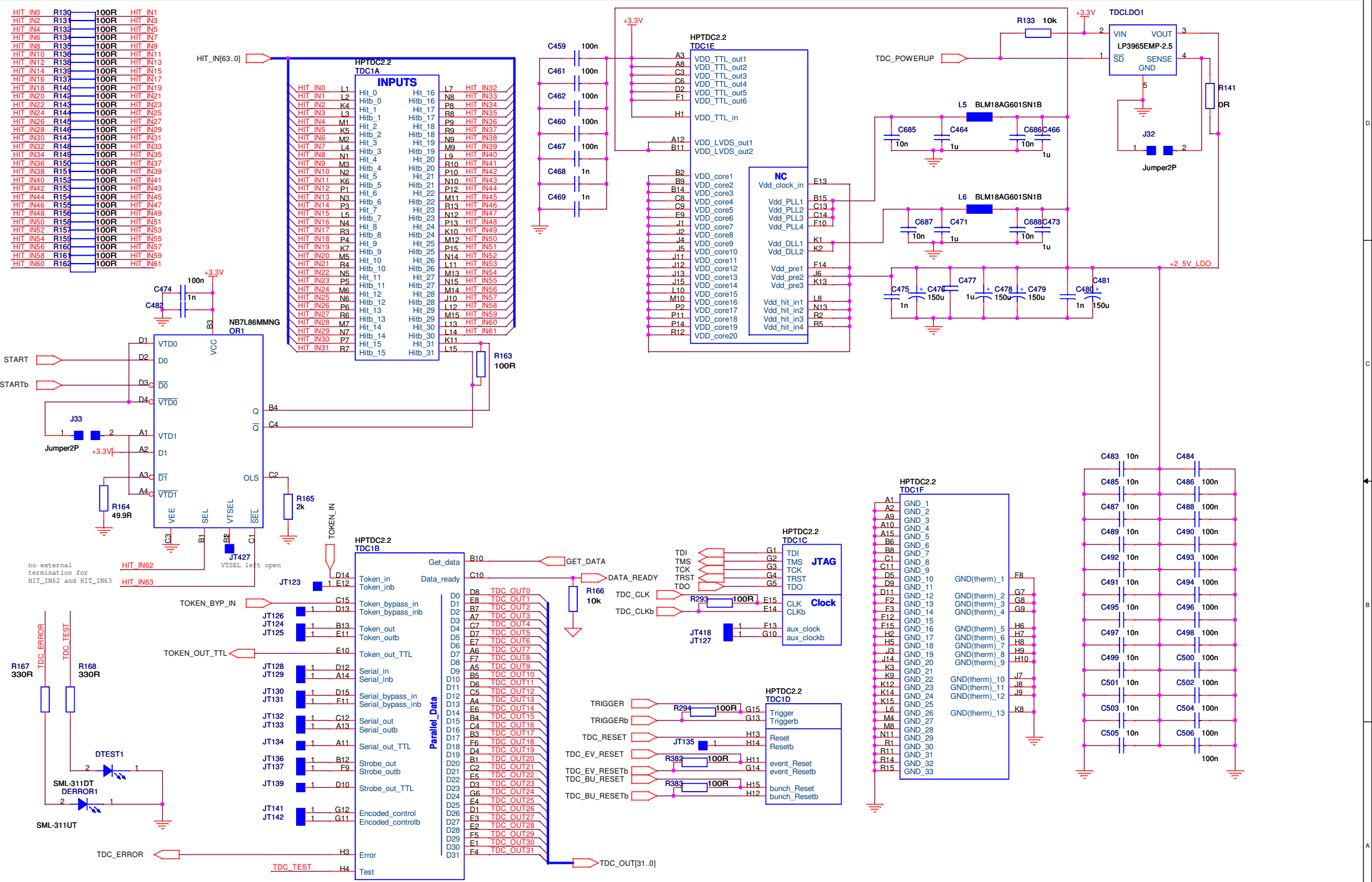

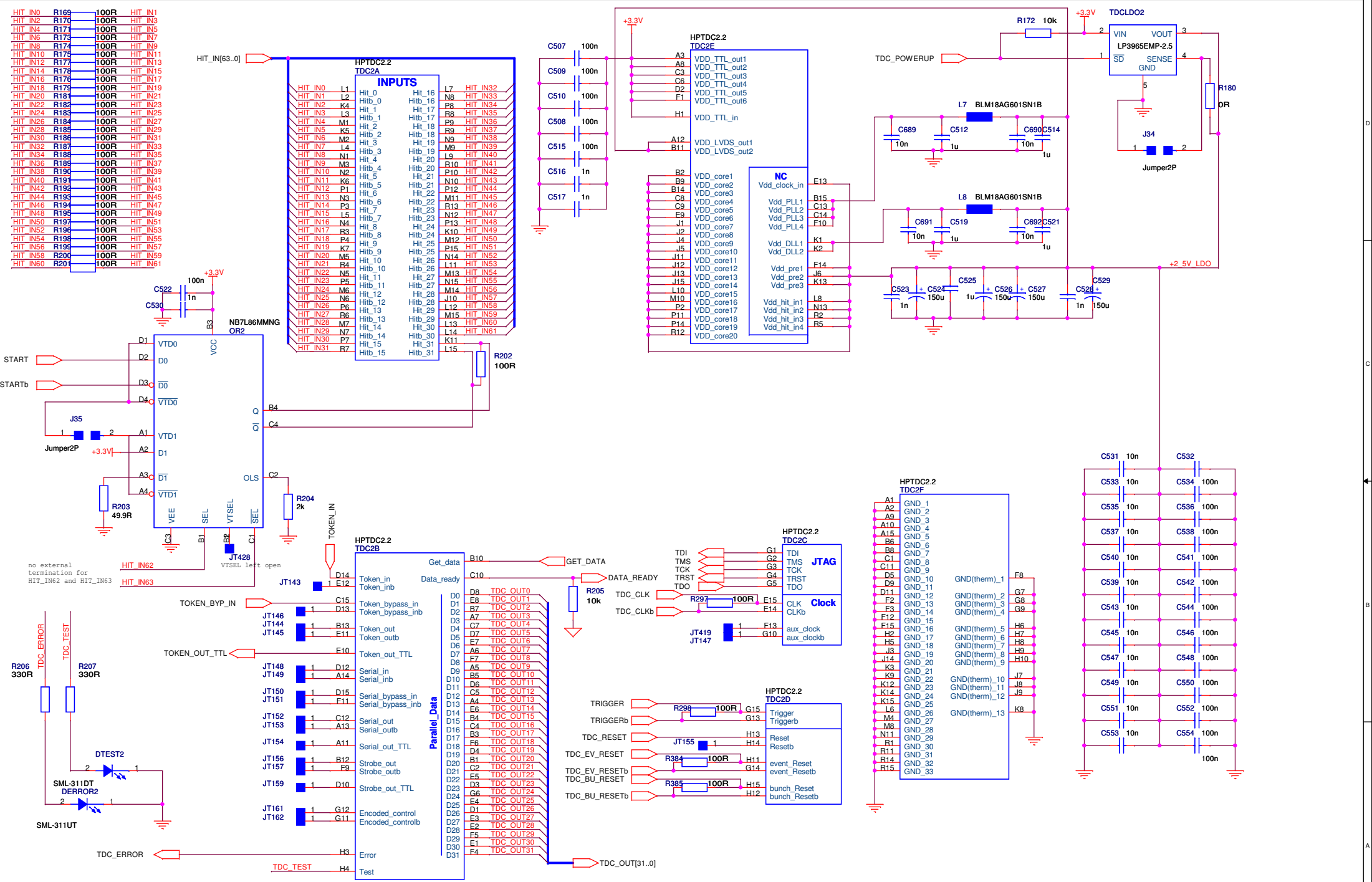

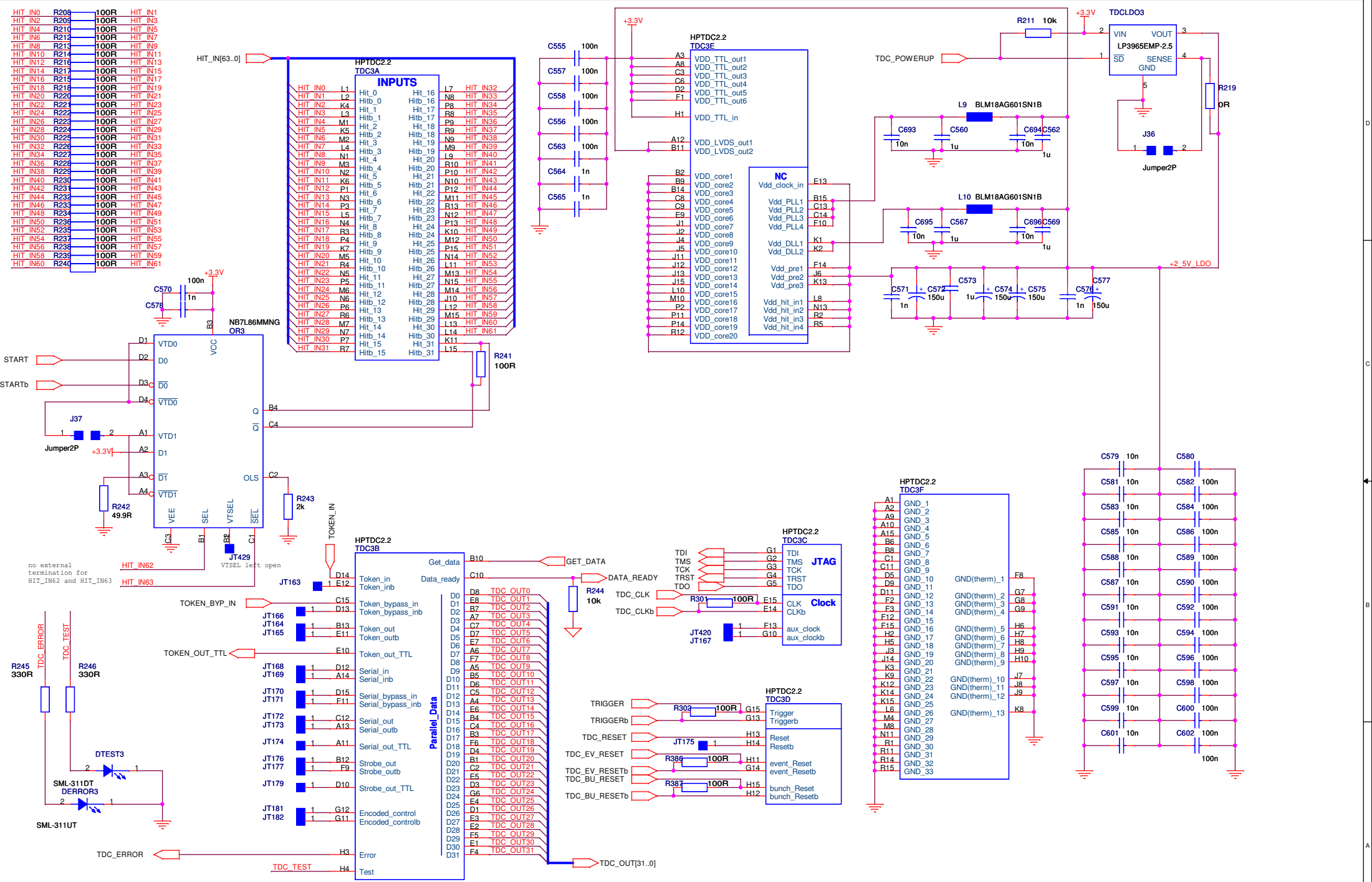

Title		<b>TDC</b>	
Size	A3	Document Number	<Doc>
Date:	Tuesday, November 07, 2006	Sheet	21 of 22



