

TDC A

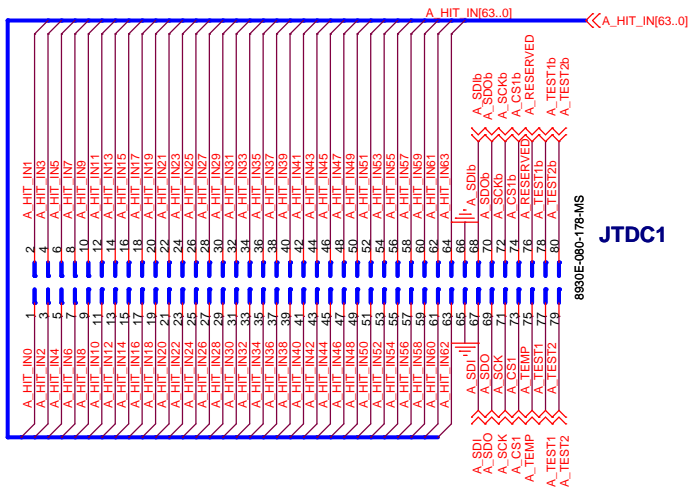

JTDC1

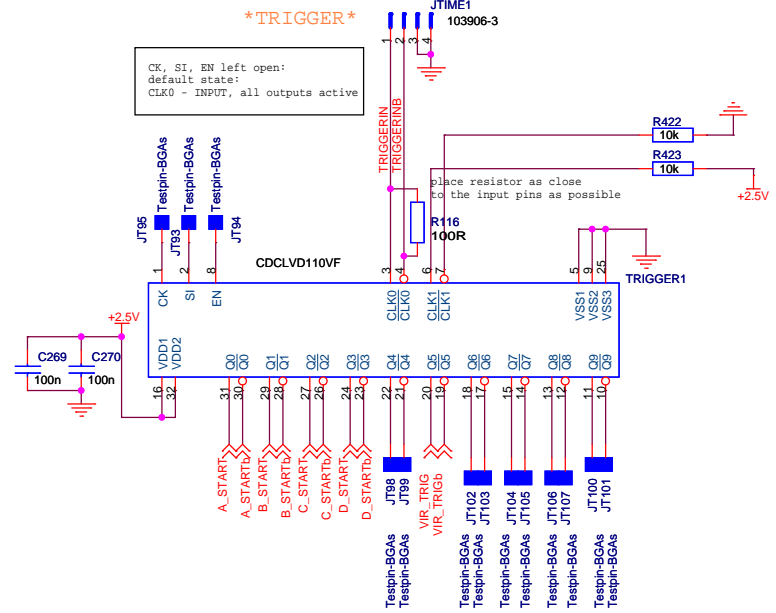

Peter, please make each next START diff. lines 0.5cm longer then the former ones. e.g. if A\_START and A\_STARTb have 35 mm then B\_START and B\_STARTb should have 40mm

TDC B

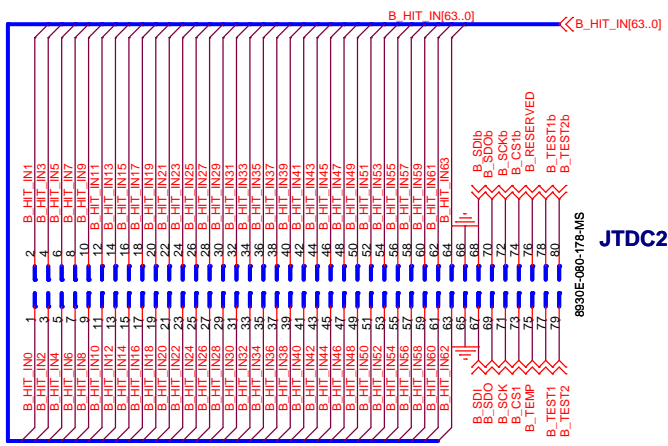

JTDC2

TDC C

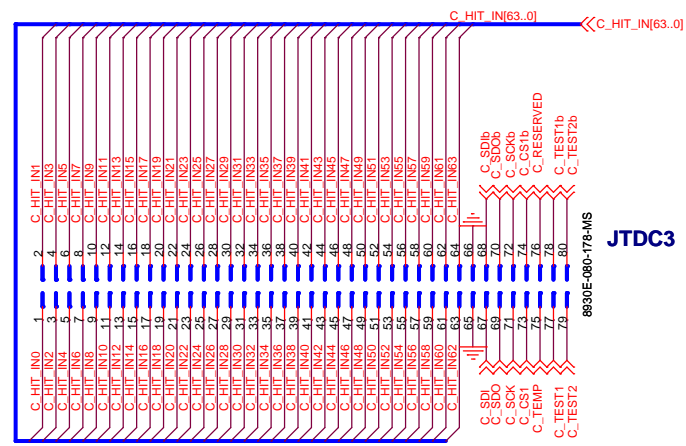

JTDC3

TDC D

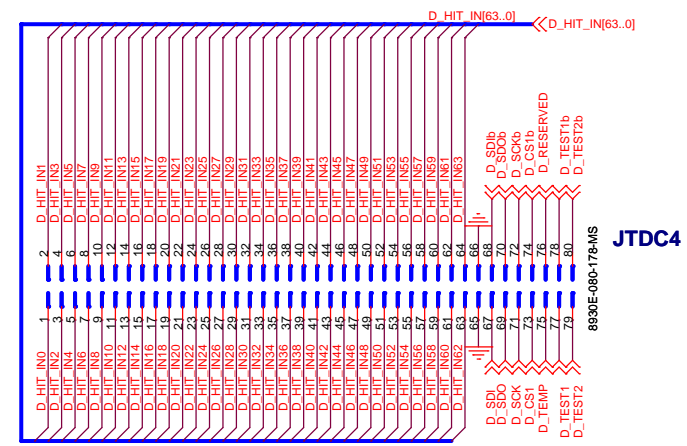

JTDC4

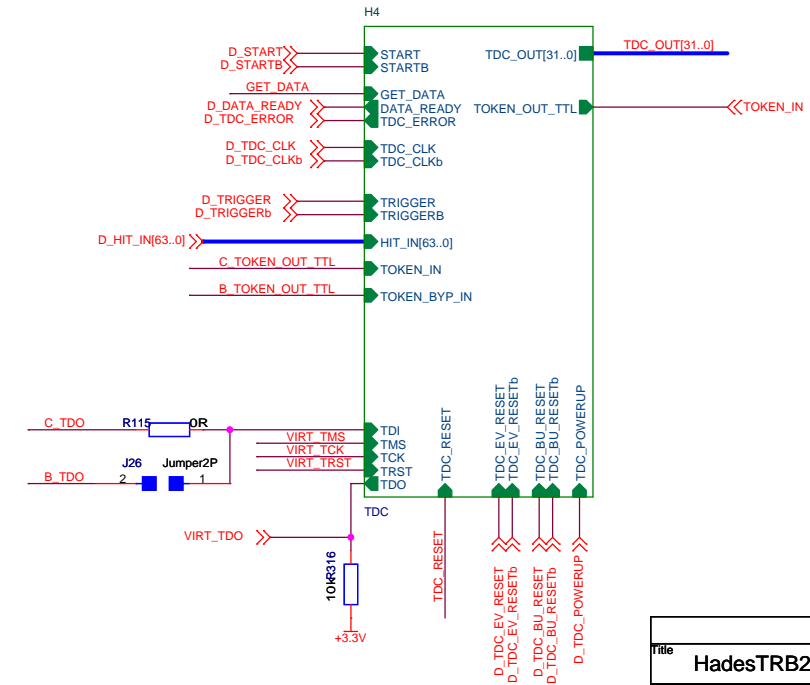
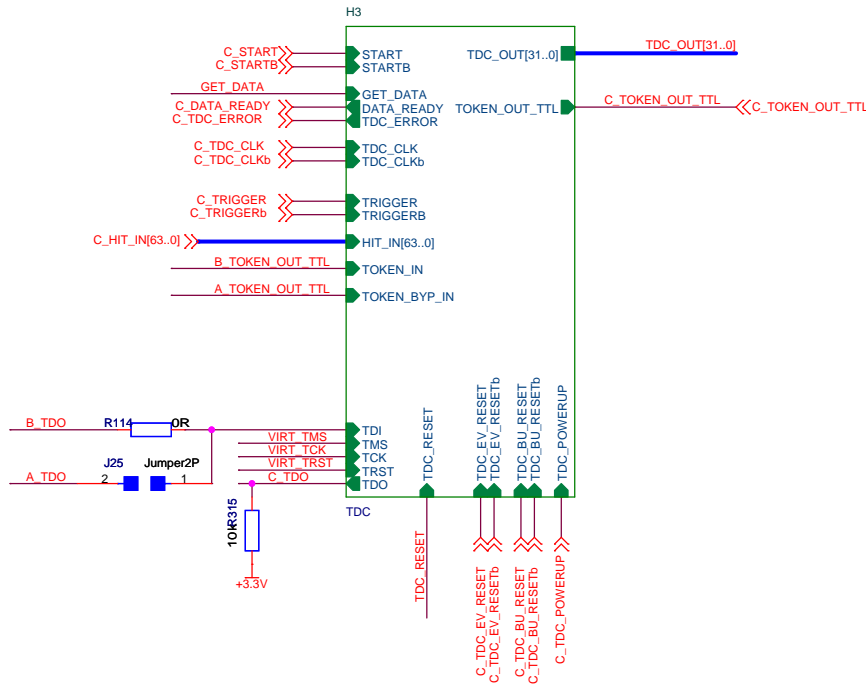
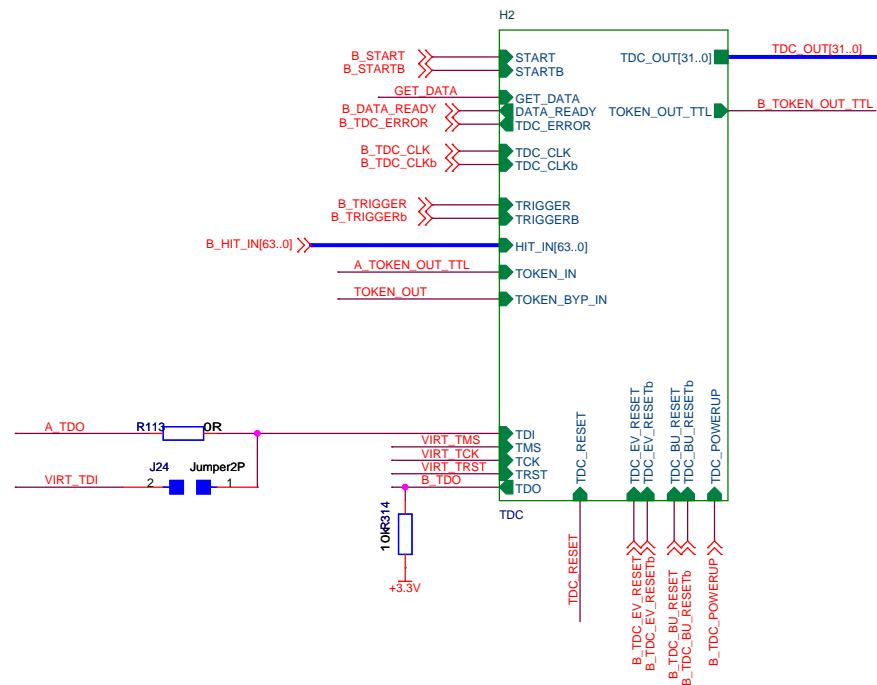
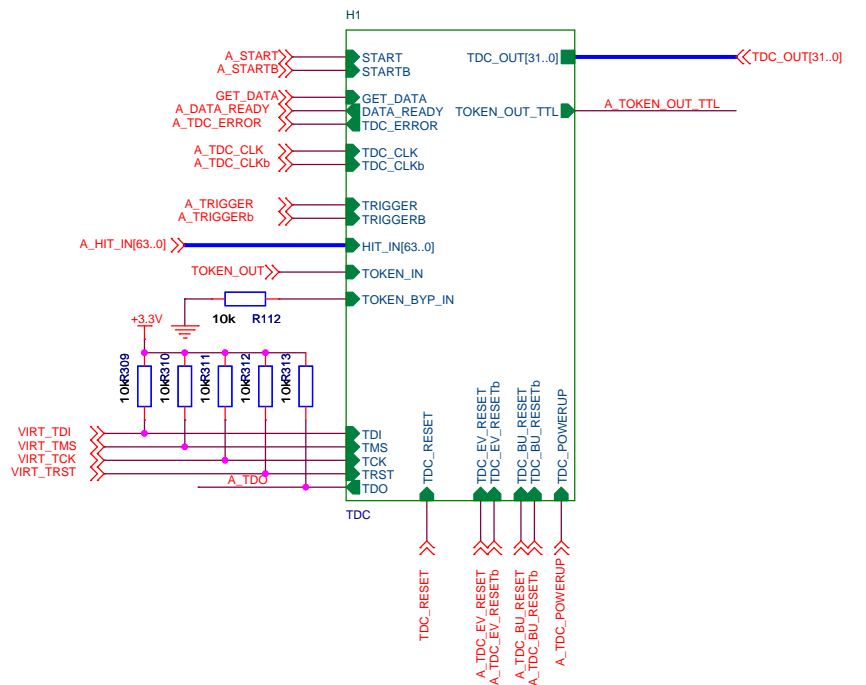

Title		
HadesTRB2 - TIME		
Size	Document Number	Rev
A3	<Doc>	b
Date:	Tuesday, February 13, 2007	Sheet 2 of 22

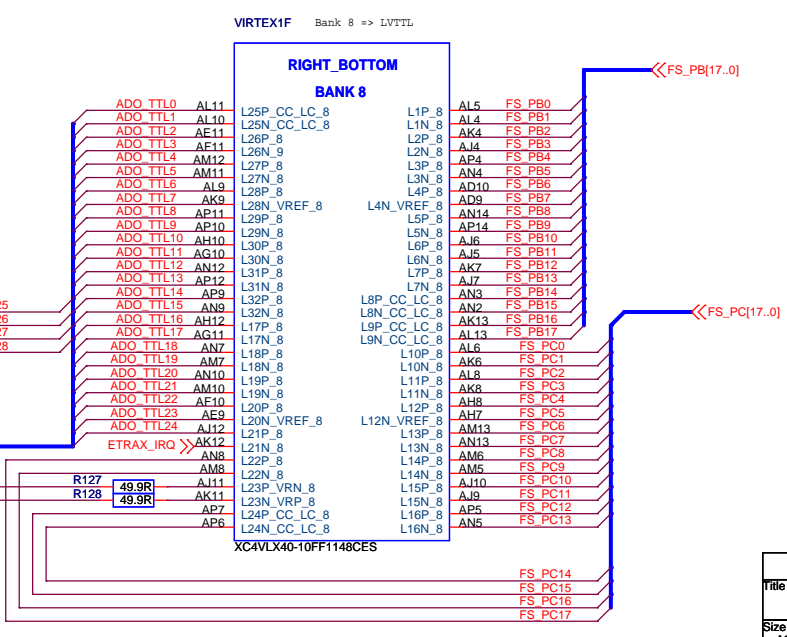
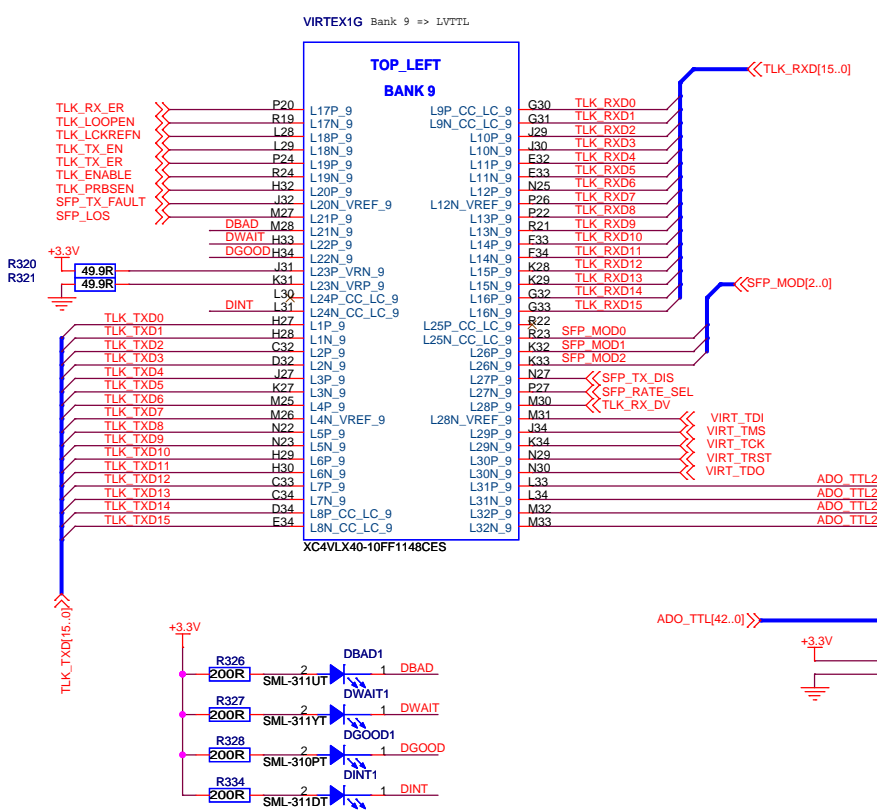
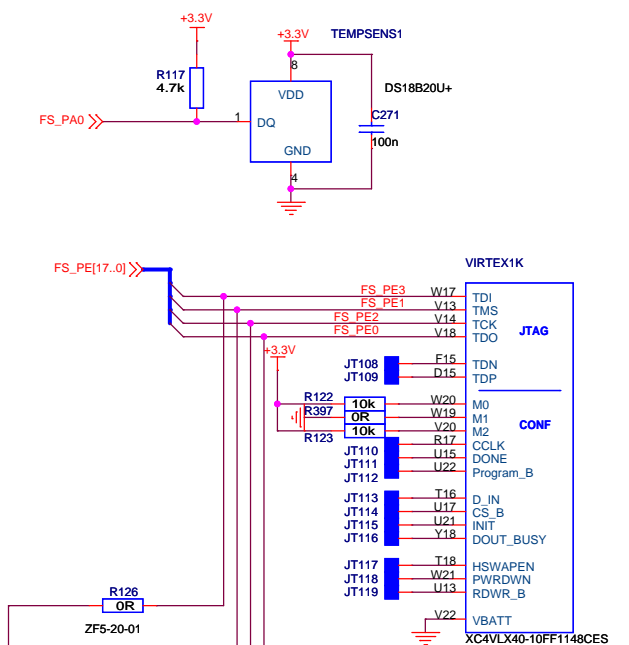
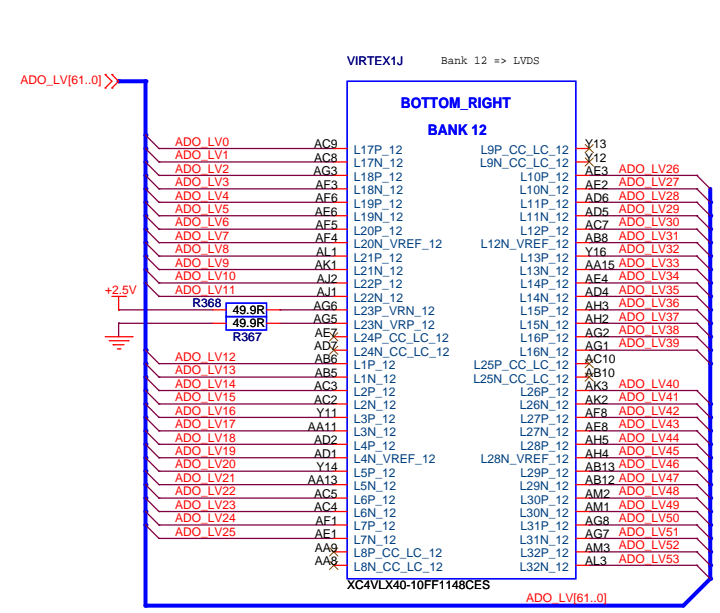

Title		
HadesTRB2 - VIRTEX A		
Size A3	Document Number <Doc>	Rev b
Date: Tuesday, February 13, 2007	Sheet 3	of 22

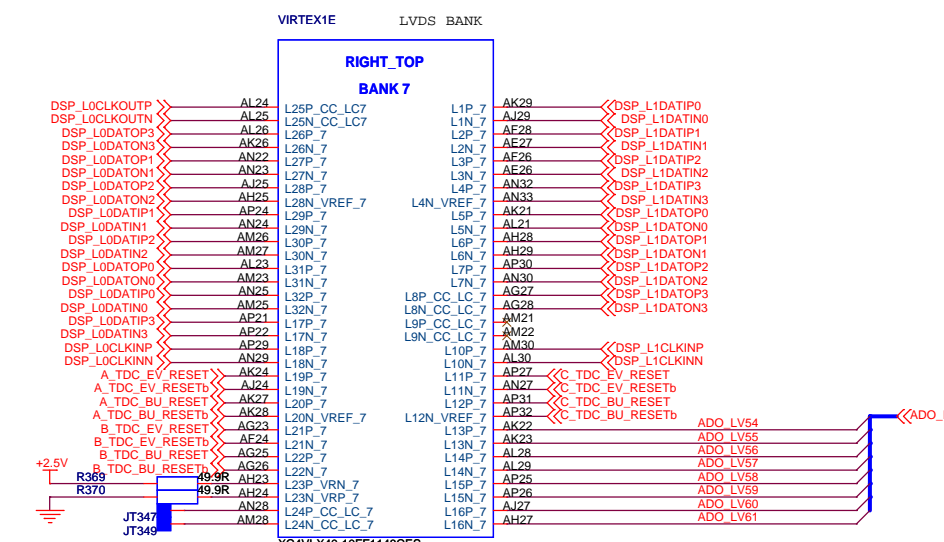
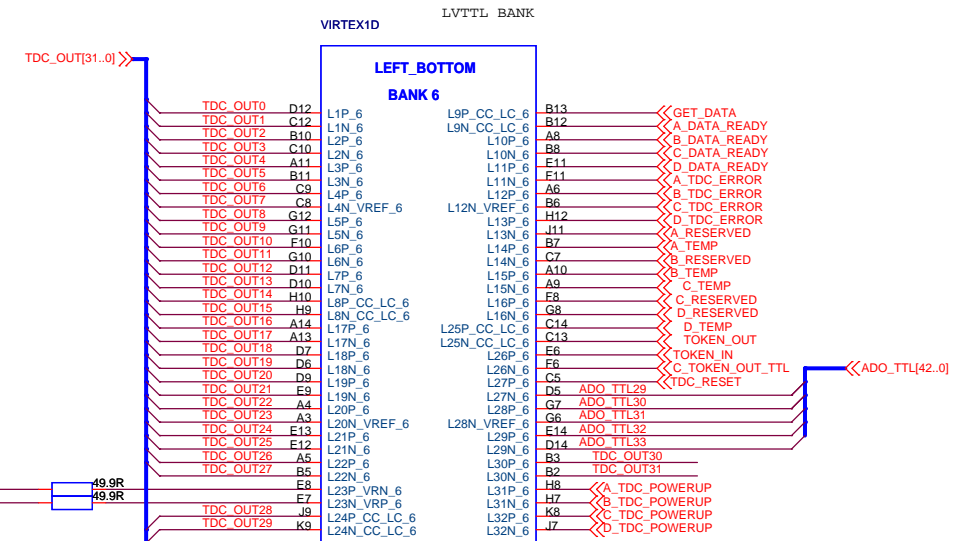
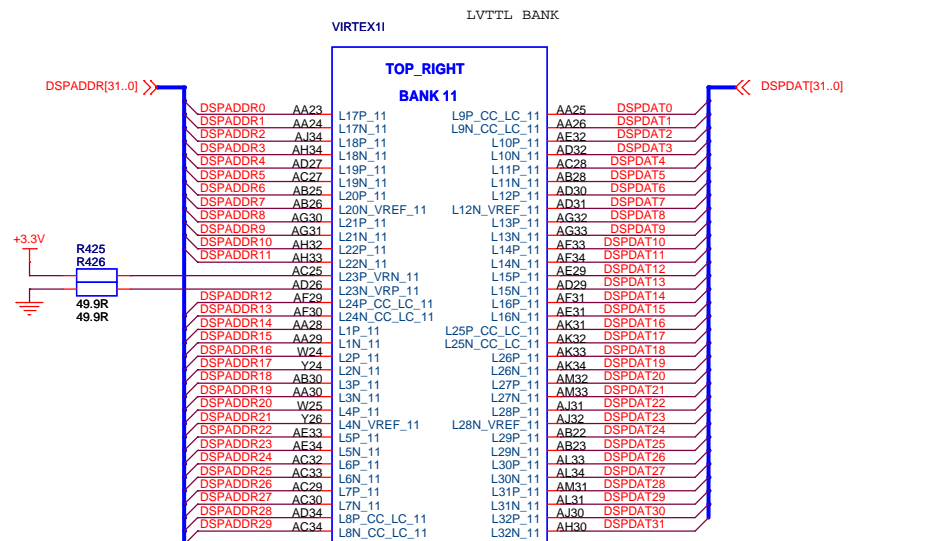
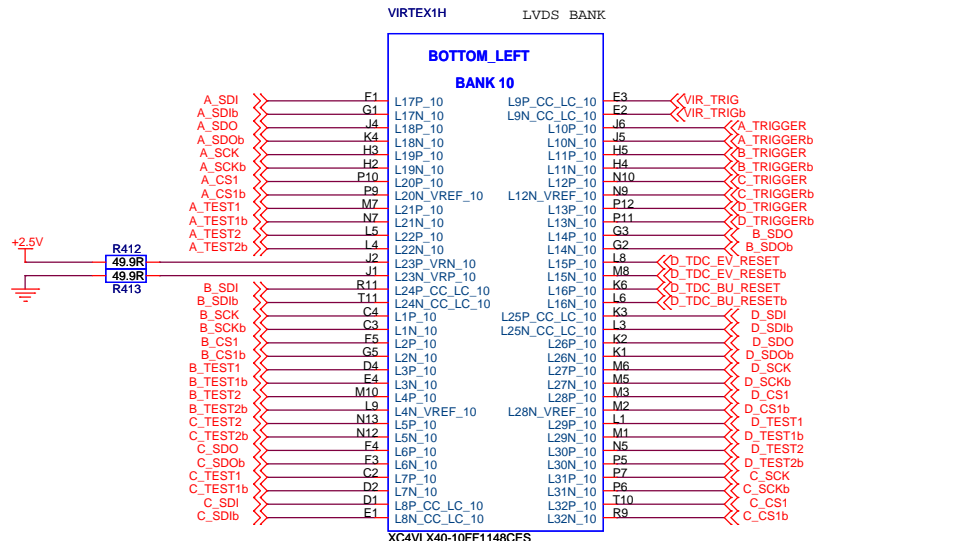

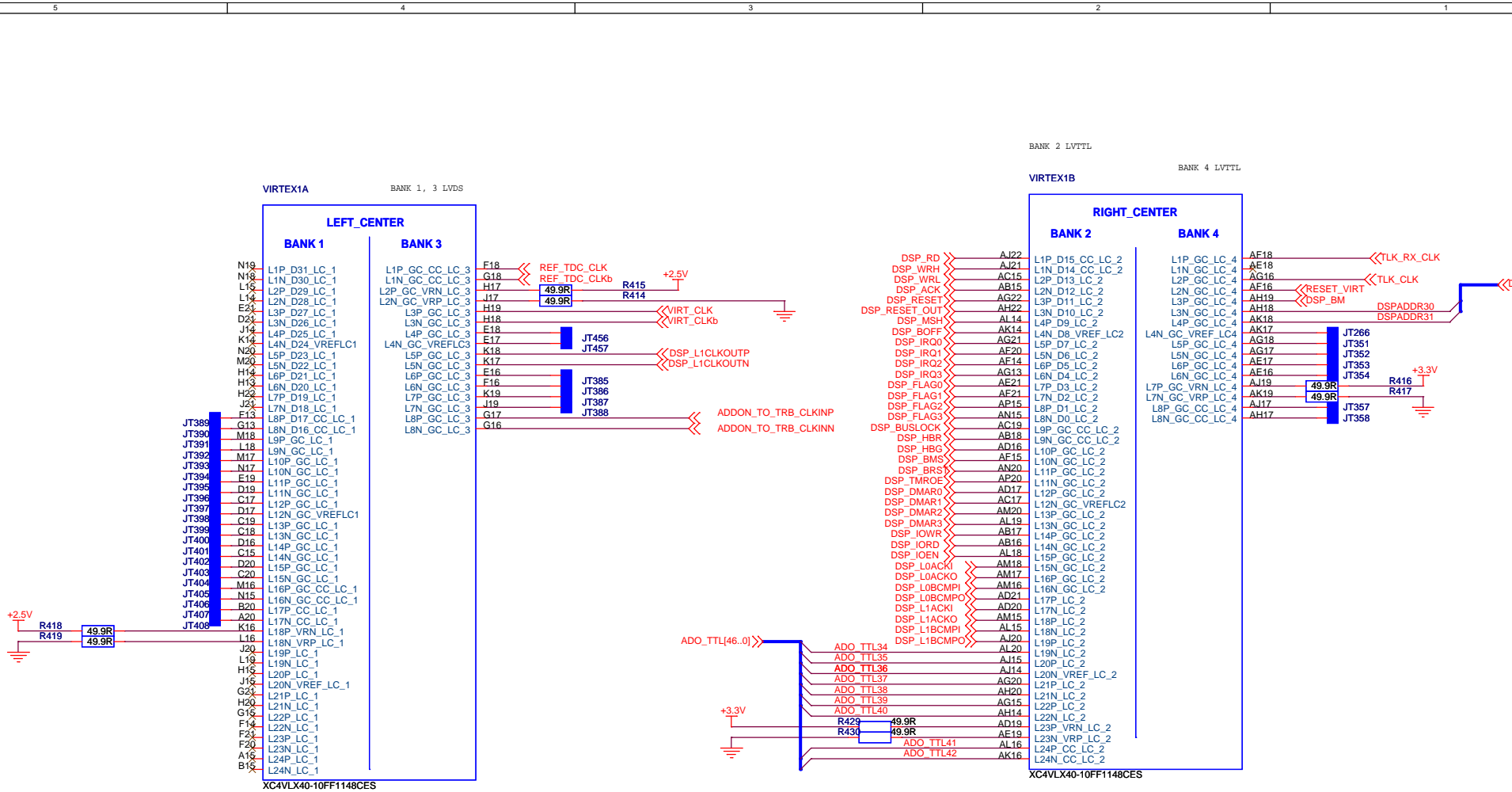

DSP control - banks 2, 7, 11

Title		
HadesTRB2 - VIRTEX C		
Size	Document Number	Rev
A3	<Doc>	b
Date:	Tuesday, February 13, 2007	Sheet 5 of 22

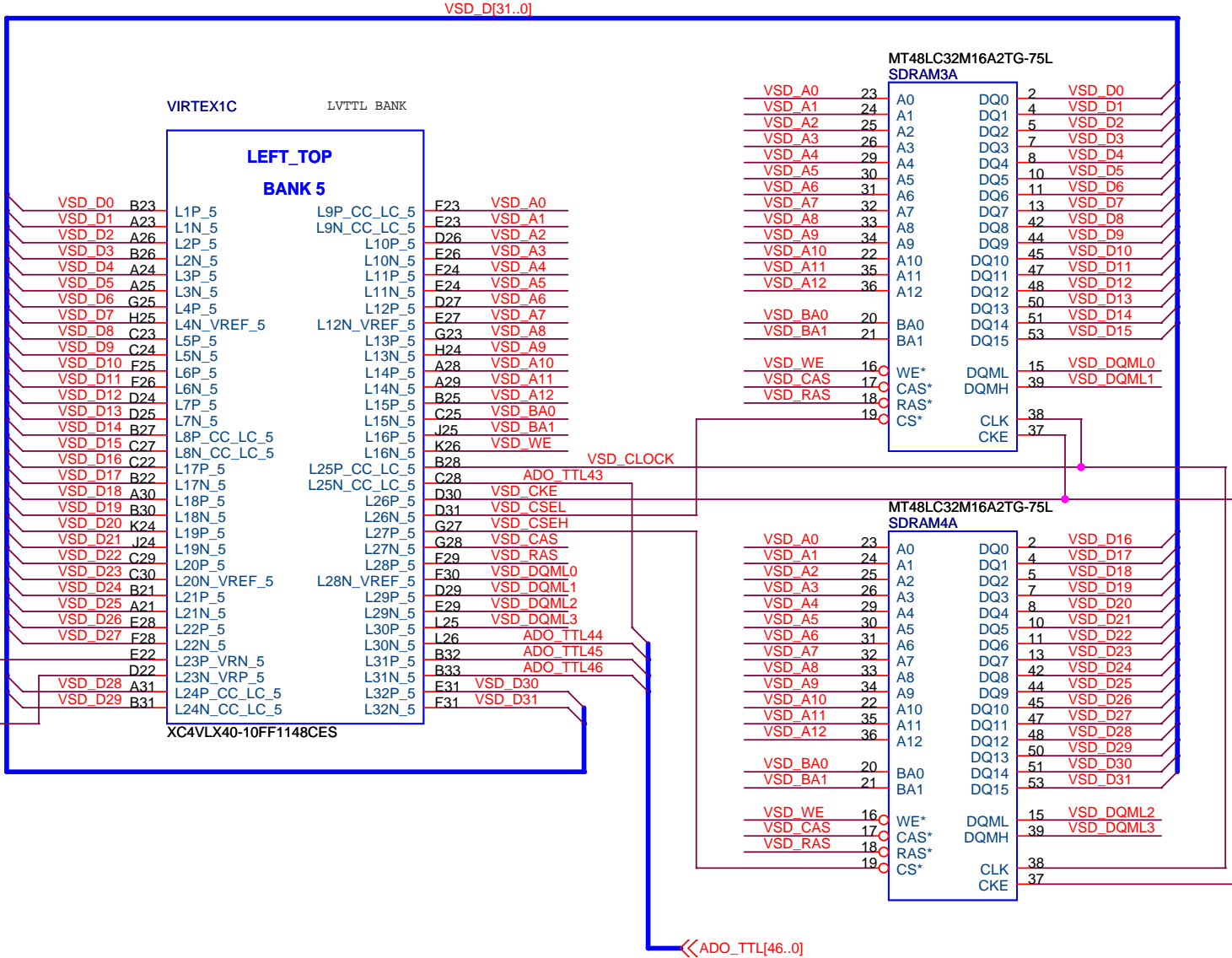





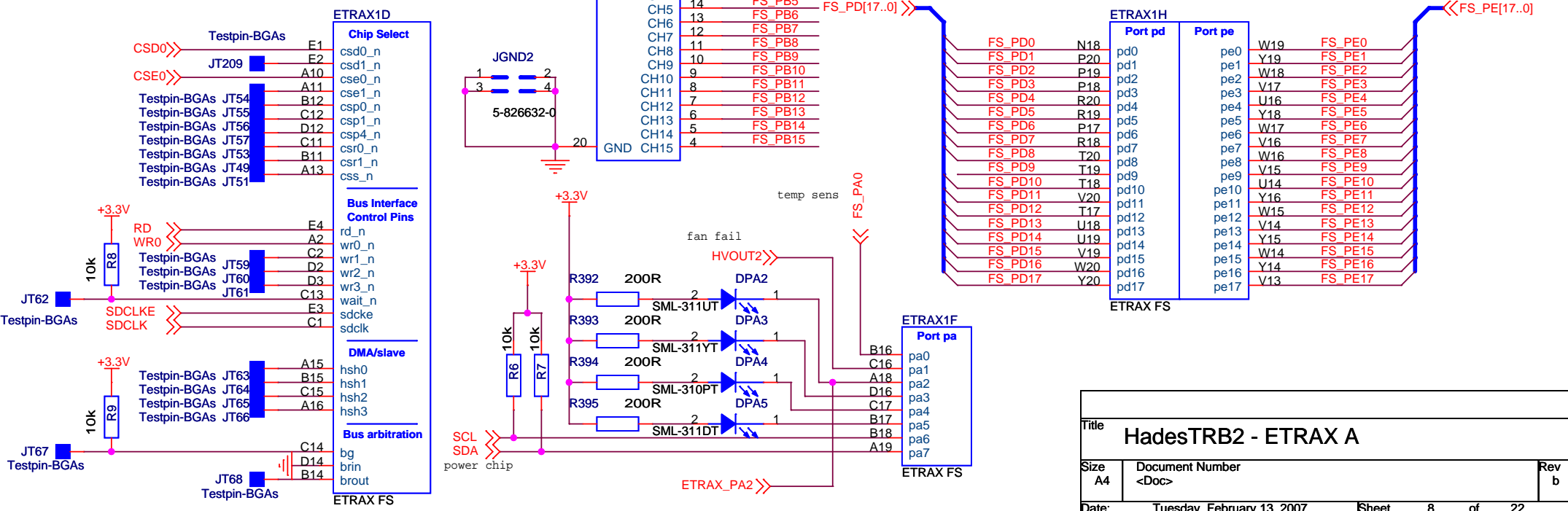
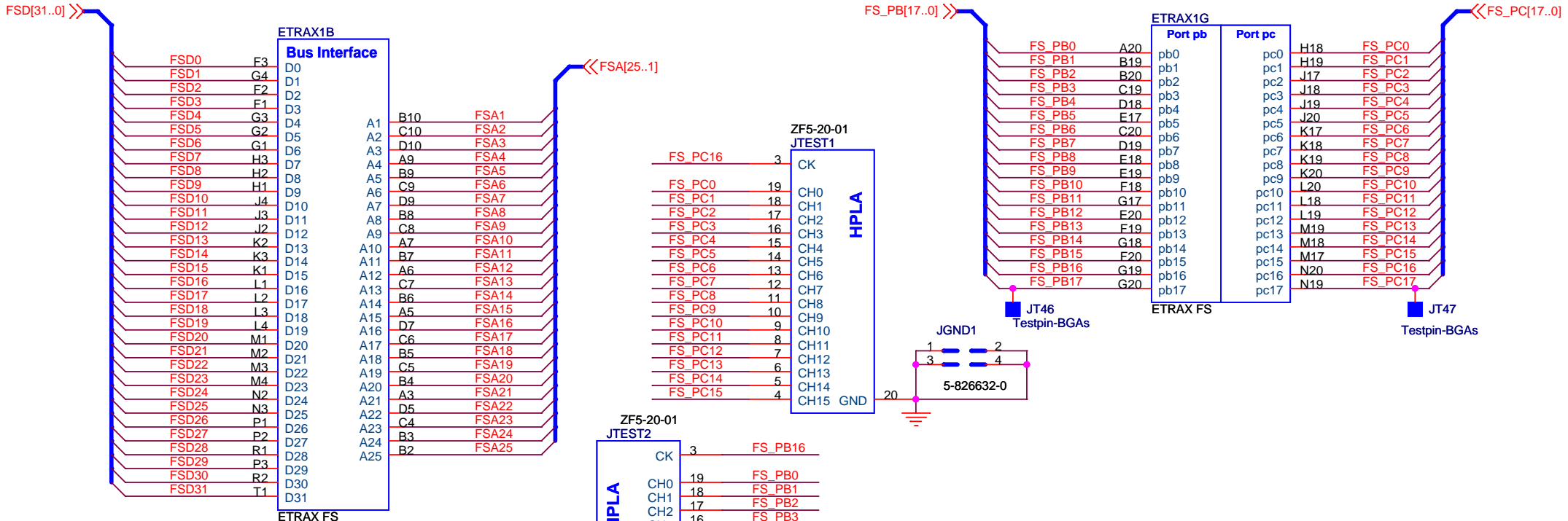

Title		
HadesTRB2 - ETRAX A		
Size	Document Number	Rev
A4	<Doc>	b
Date:	Tuesday, February 13, 2007	Sheet 8 of 22



Place the termination network and RJ45 connector close to the BCM5221

BS3	BS2	BS1	BS0	
-	0	0	0	NOR Flash
-	0	0	1	Network RX only
-	0	1	0	Network RX/TX
-	0	1	1	NAND Flash
-	1	0	0	Serial
-	1	0	1	Master boot
-	1	1	0	Slave boot
-	1	1	1	No boot
0	-	-	-	Ethernet Half-Duplex
1	-	-	-	Ethernet Full-Duplex

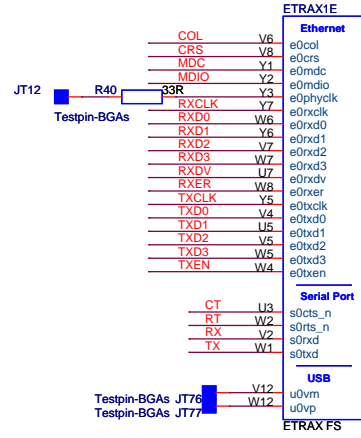
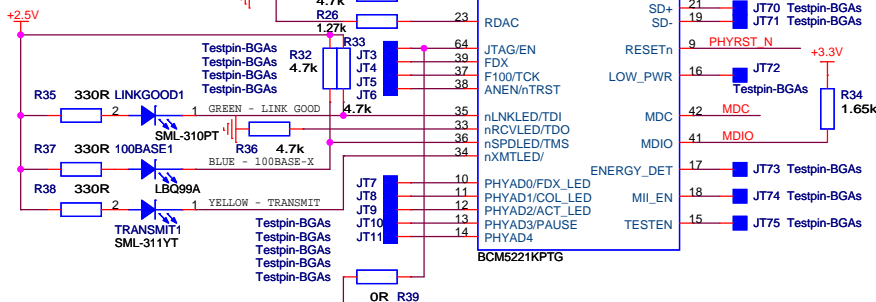
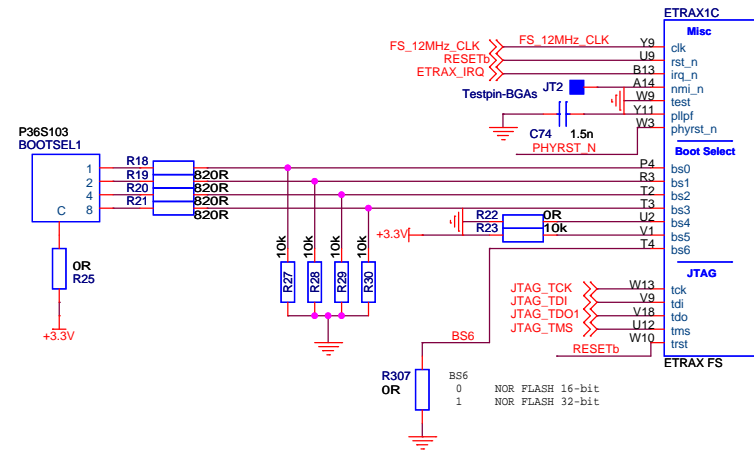
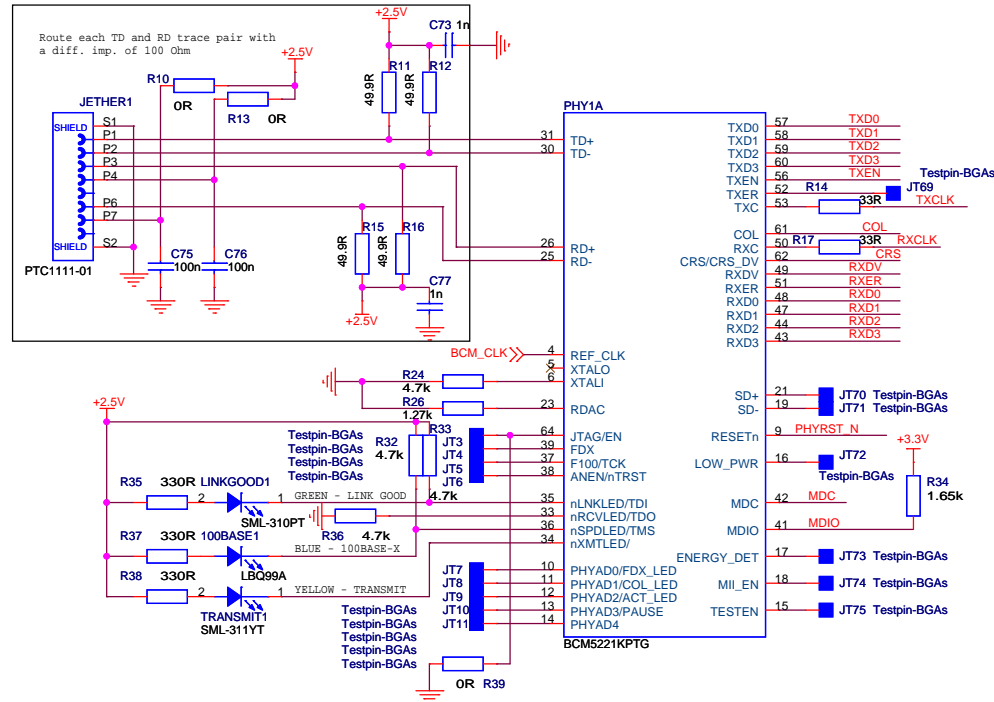

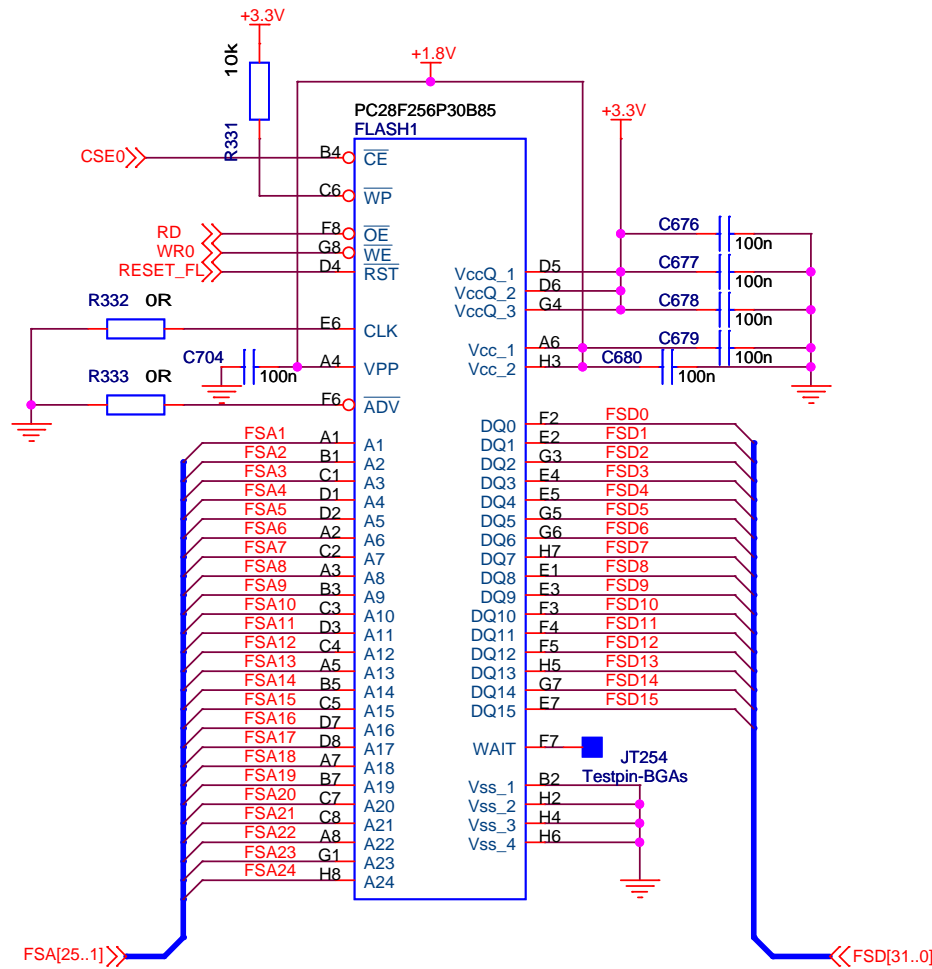

Title		
HadesTRB2 - FLASH MEMORY		
Size	Document Number	Rev
A4	<Doc>	b
Date:	Tuesday, February 13, 2007	Sheet 10 of 22

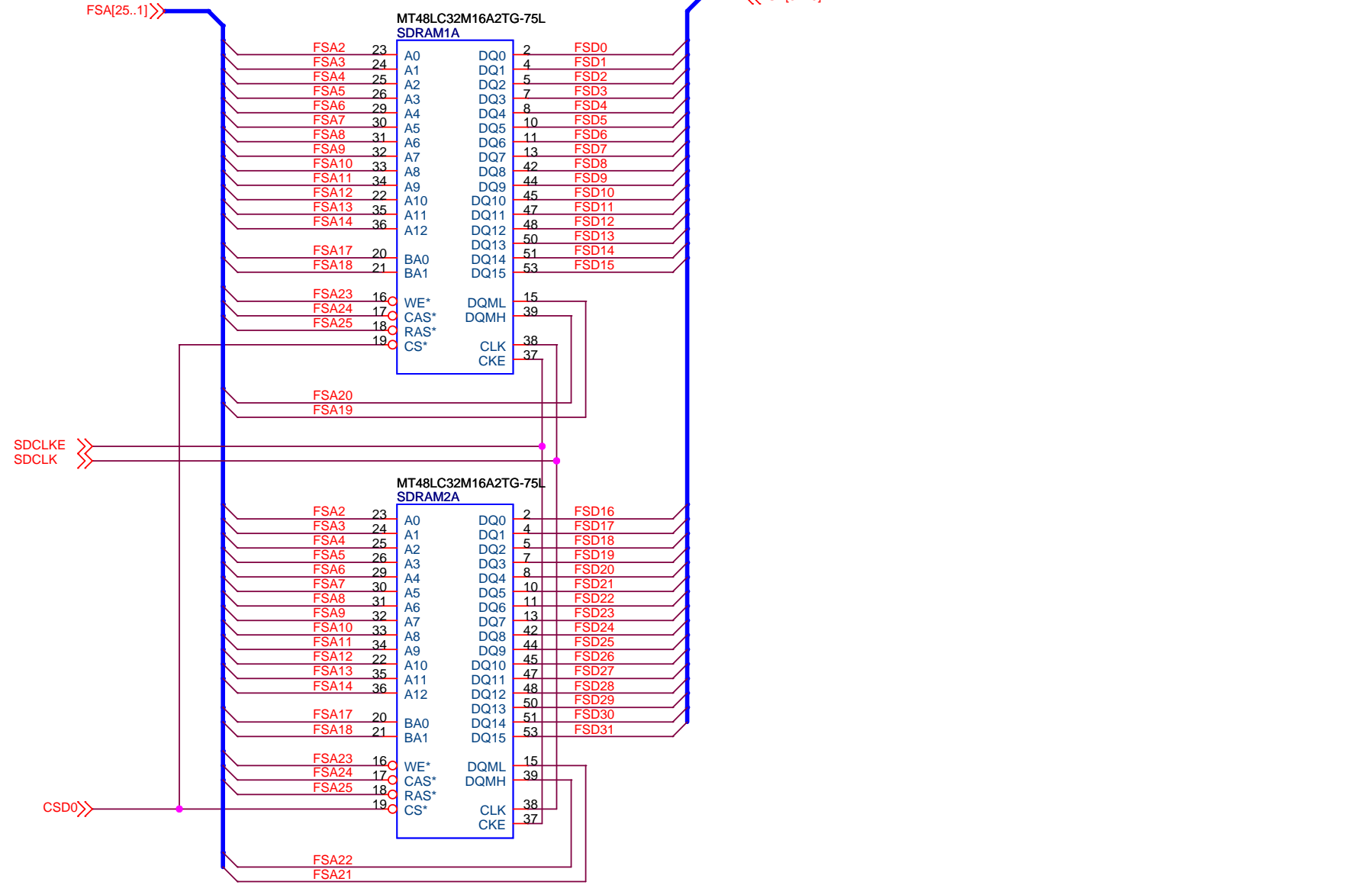

Title		
HadesTRB2 - ETRAX SDRAM		
Size	Document Number	Rev
A4	<Doc>	b
Date:	Tuesday, February 13, 2007	Sheet 11 of 22



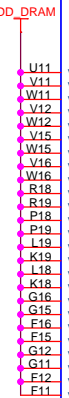
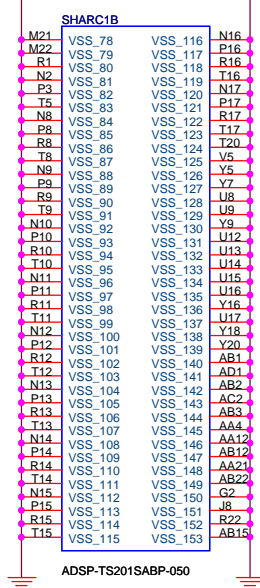
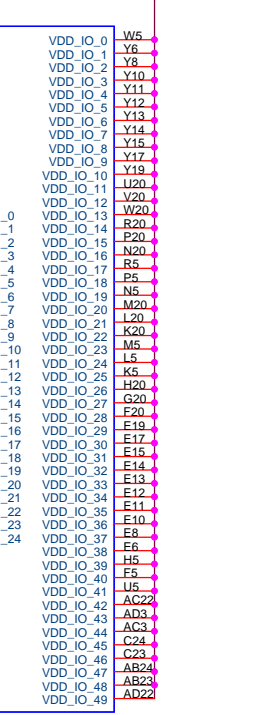
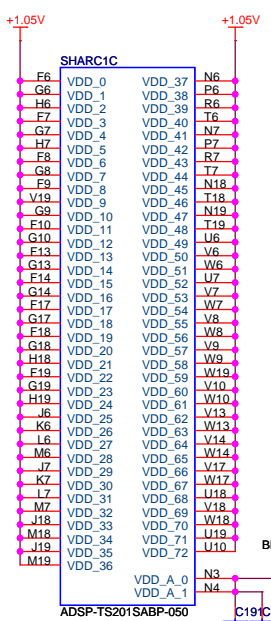
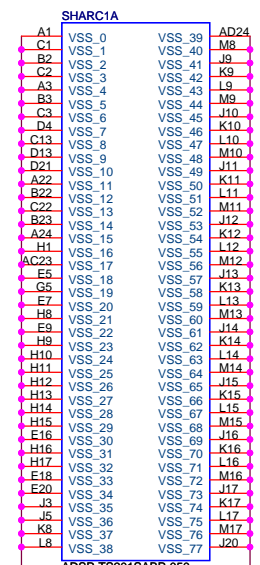

ADSP-TS201SABP-050



Title		
HadesTRB2 - SHARC SUPPLY		
Size	Document Number	Rev
A3	<Doc>	b
Date:	Tuesday, February 13, 2007	Sheet 13 of 22

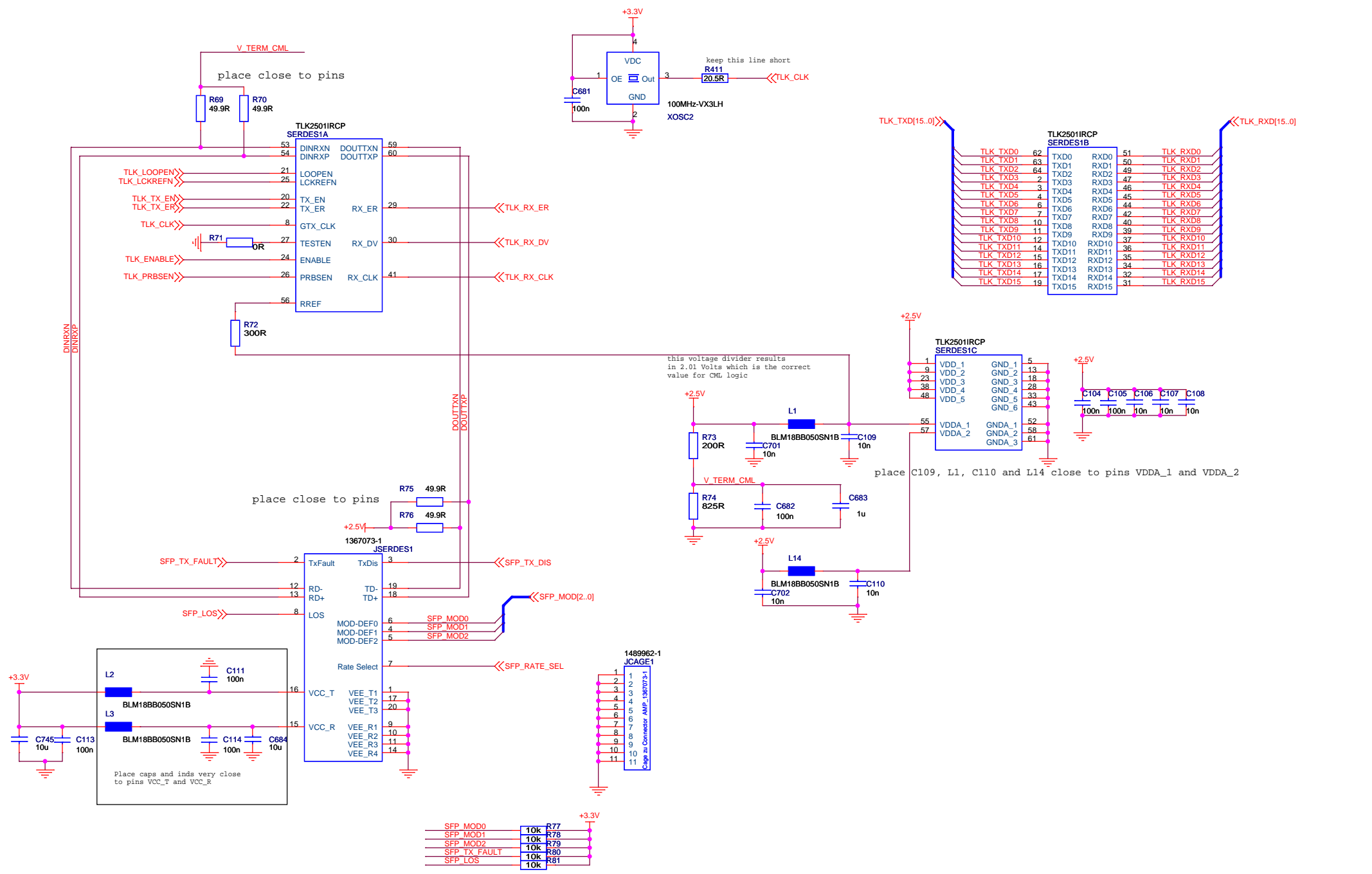

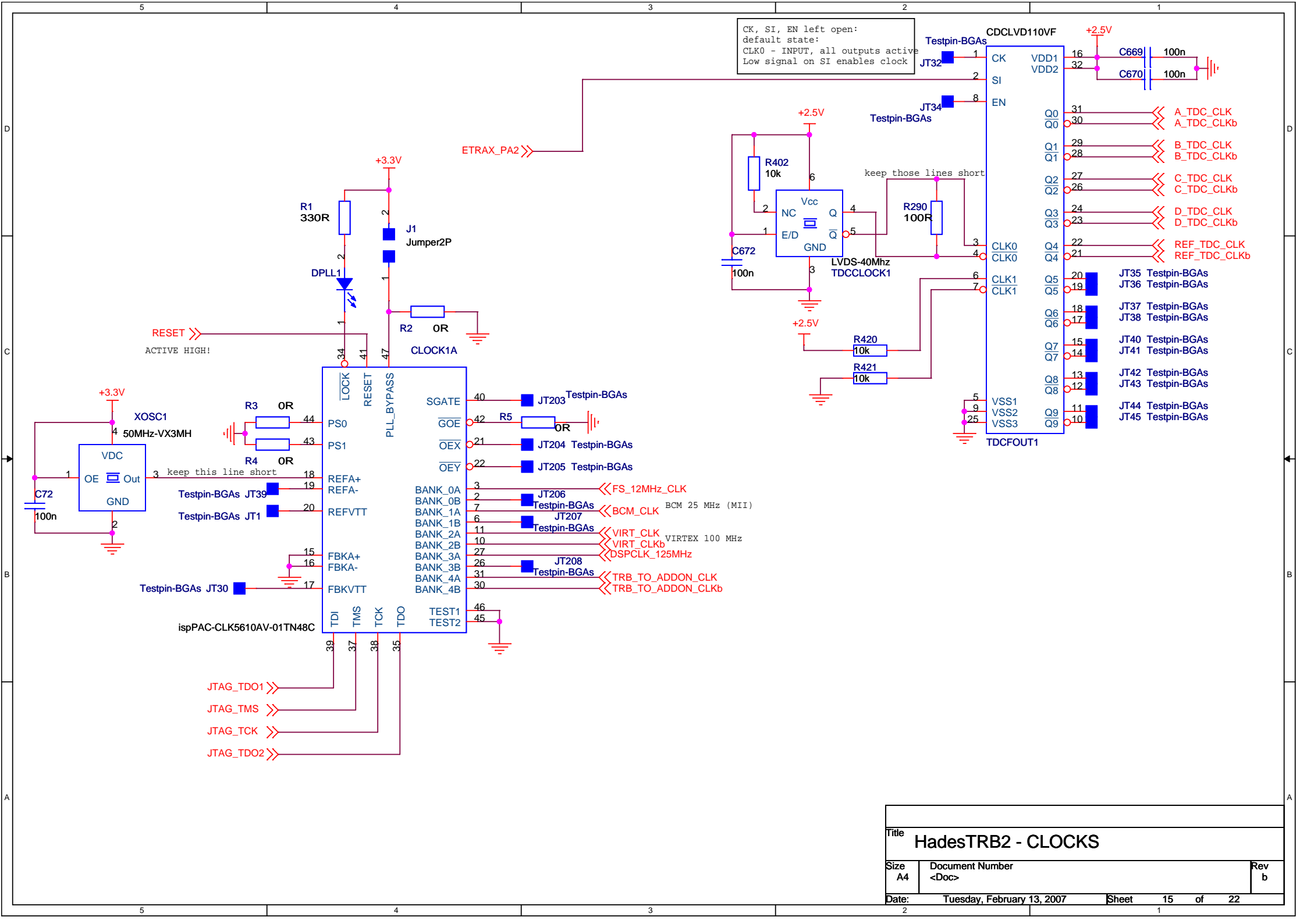

CK, SI, EN left open:  
 default state:  
 CLK0 - INPUT, all outputs active  
 Low signal on SI enables clock

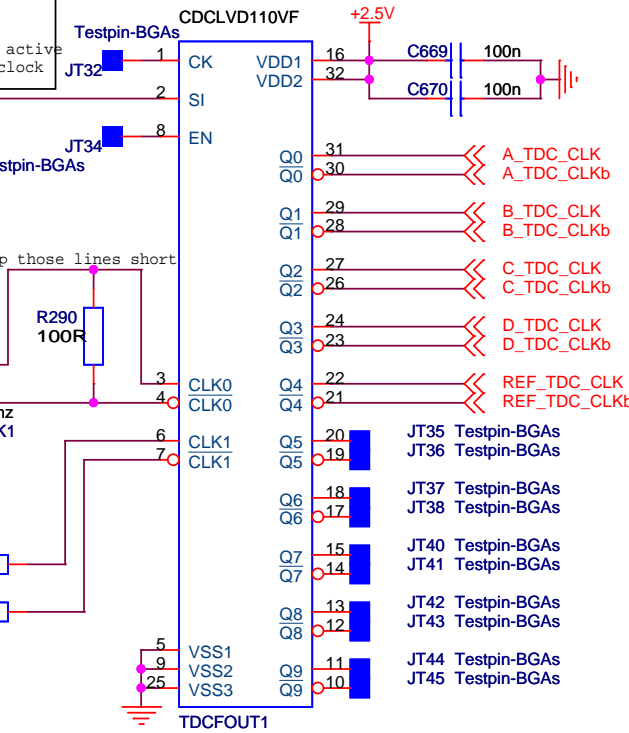

Title		
HadesTRB2 - CLOCKS		
Size	Document Number	Rev
A4	<Doc>	b
Date:	Tuesday, February 13, 2007	Sheet 15 of 22



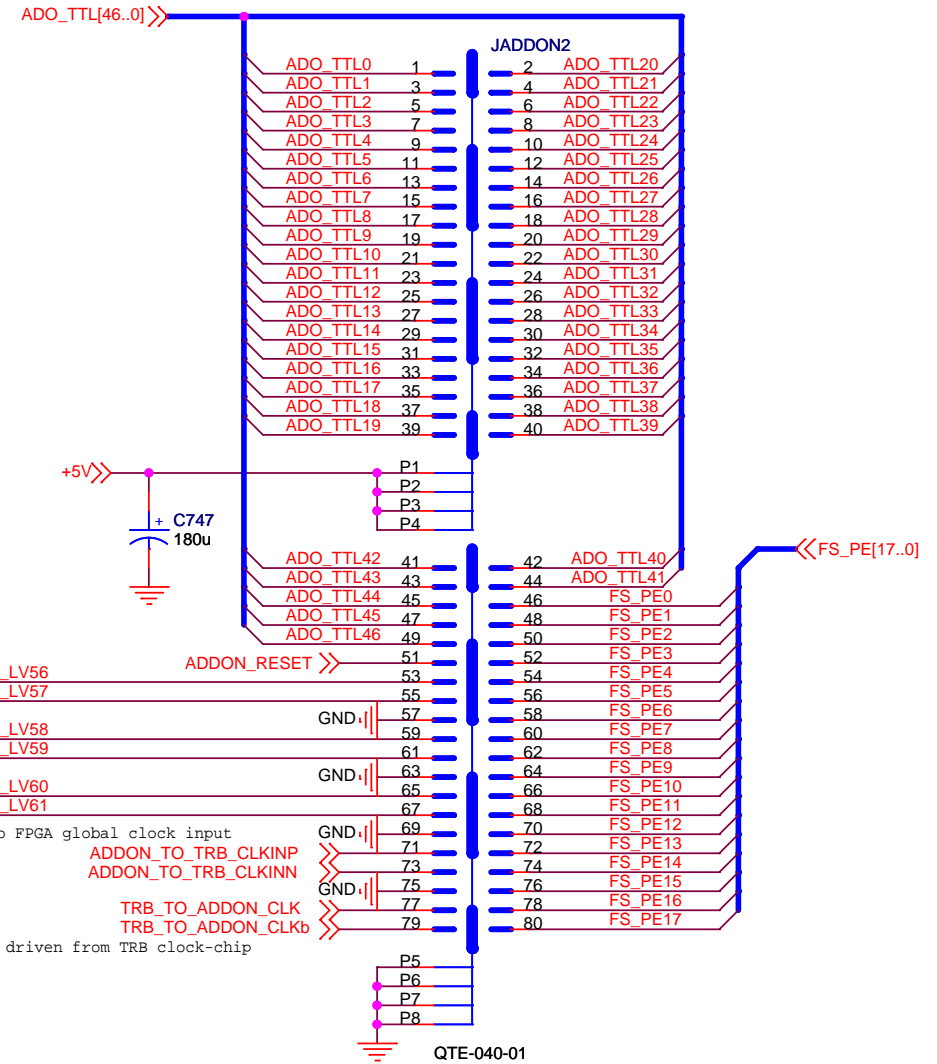
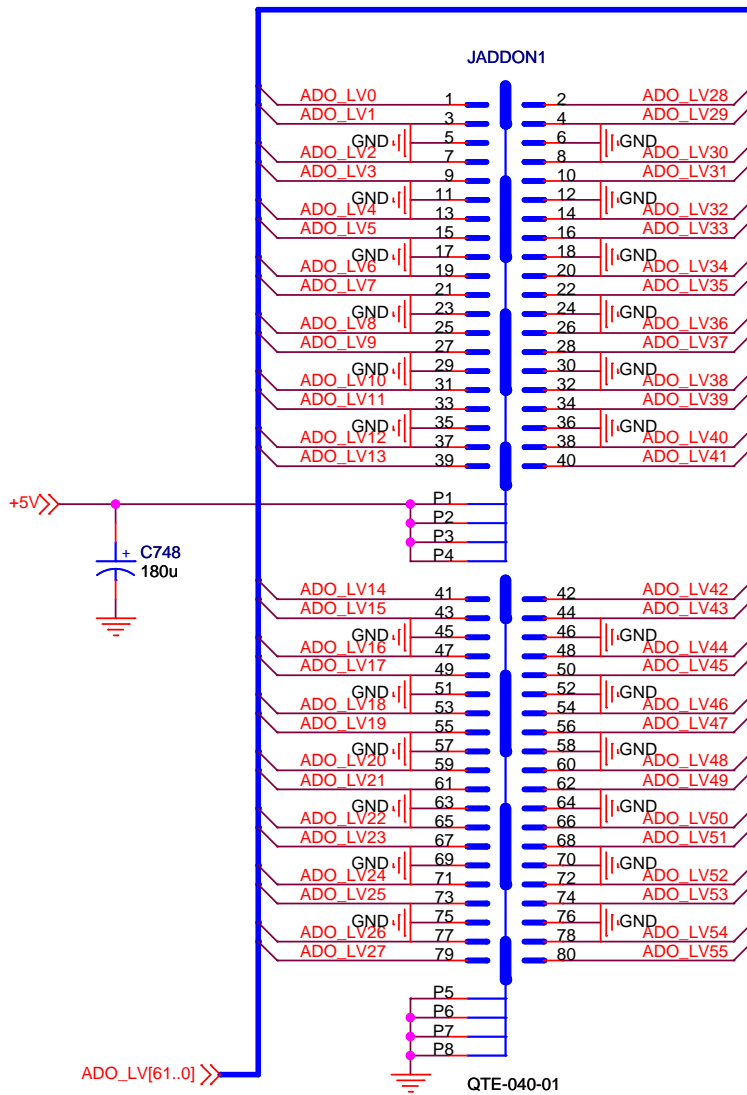
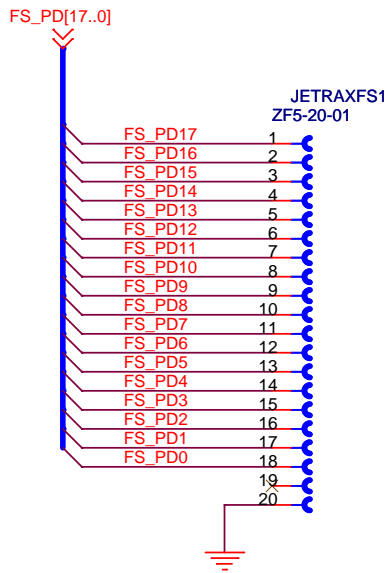

Title		
HadesTRB2 - CONNECTORS		
Size	Document Number	Rev
A4	<Doc>	b
Date:	Tuesday, February 13, 2007	Sheet 16 of 22

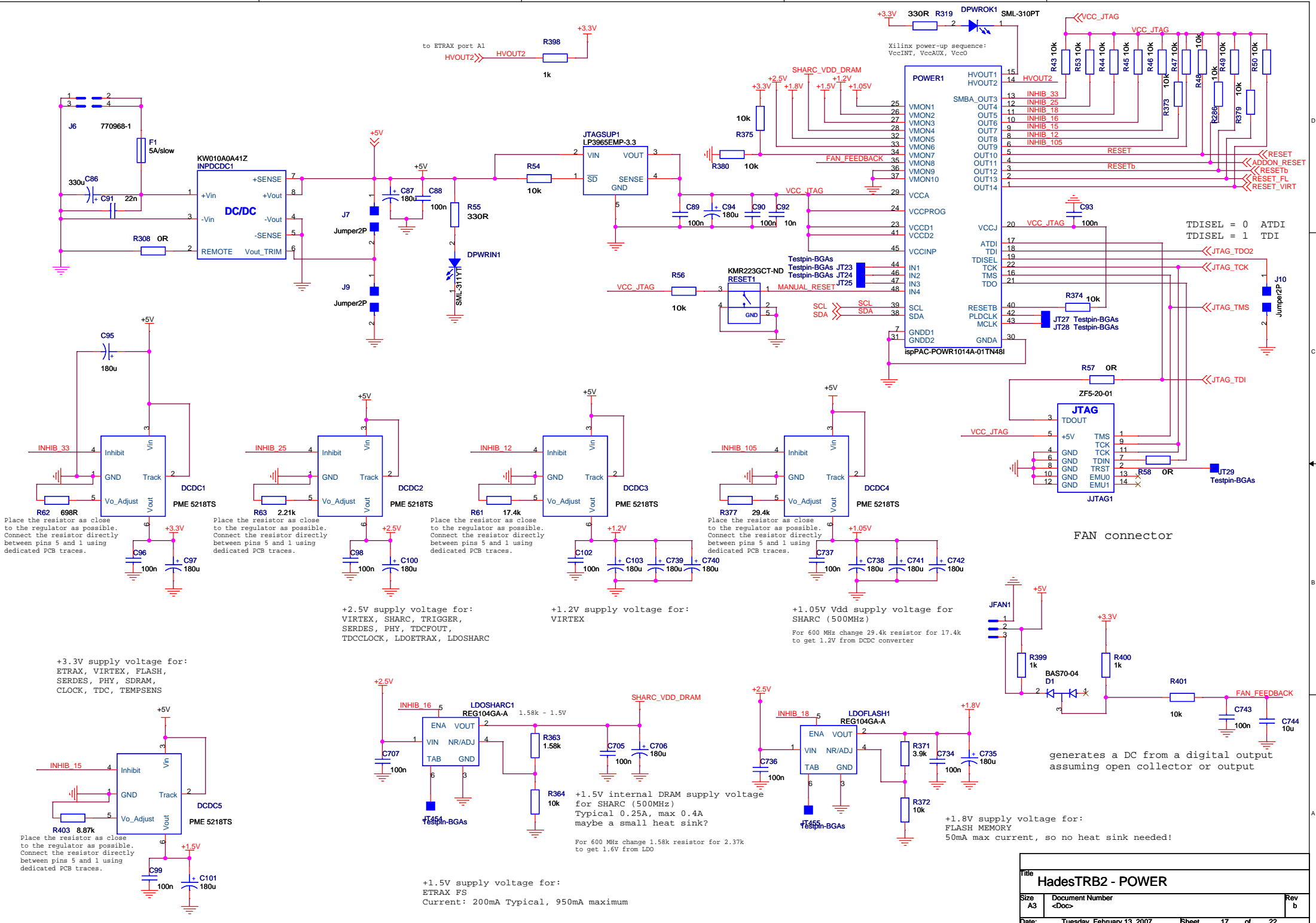

Title		
<b>HadesTRB2 - POWER</b>		
Size	Document Number	Rev
A3	<Doc>	b
Date:	Tuesday, February 13, 2007	Sheet 17 of 22

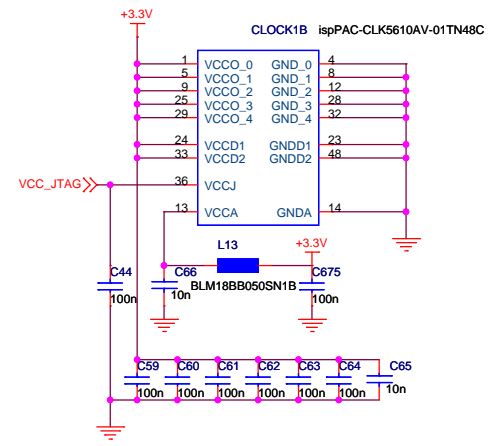
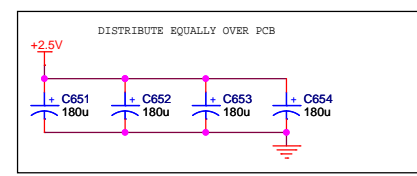
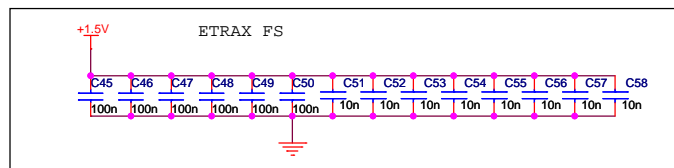
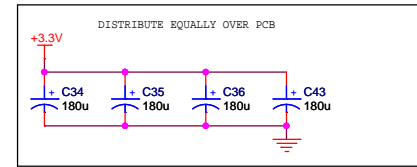
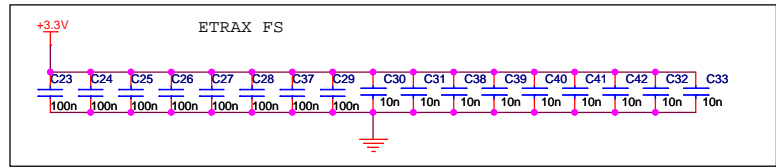
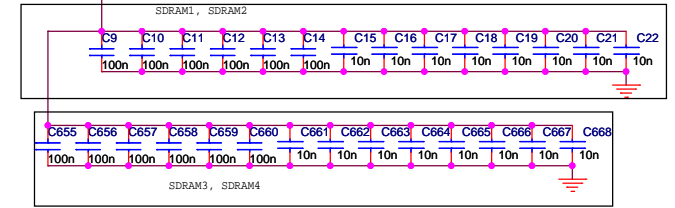
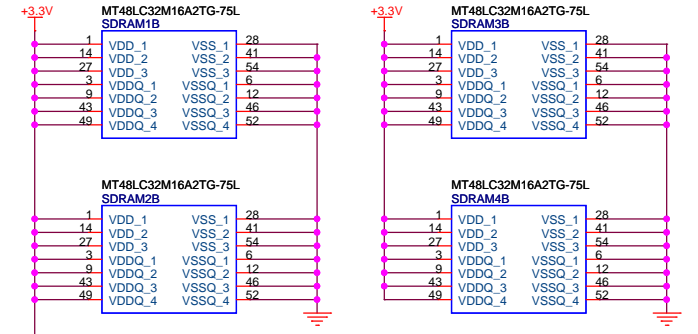
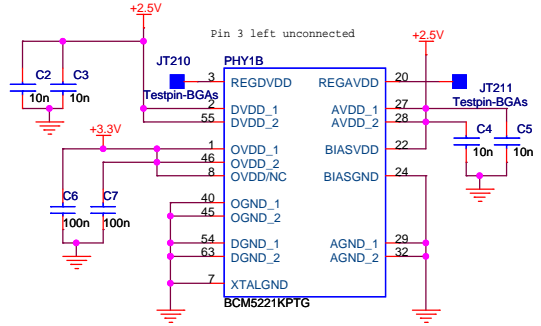
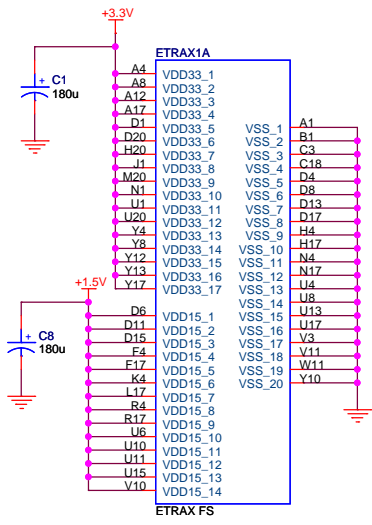

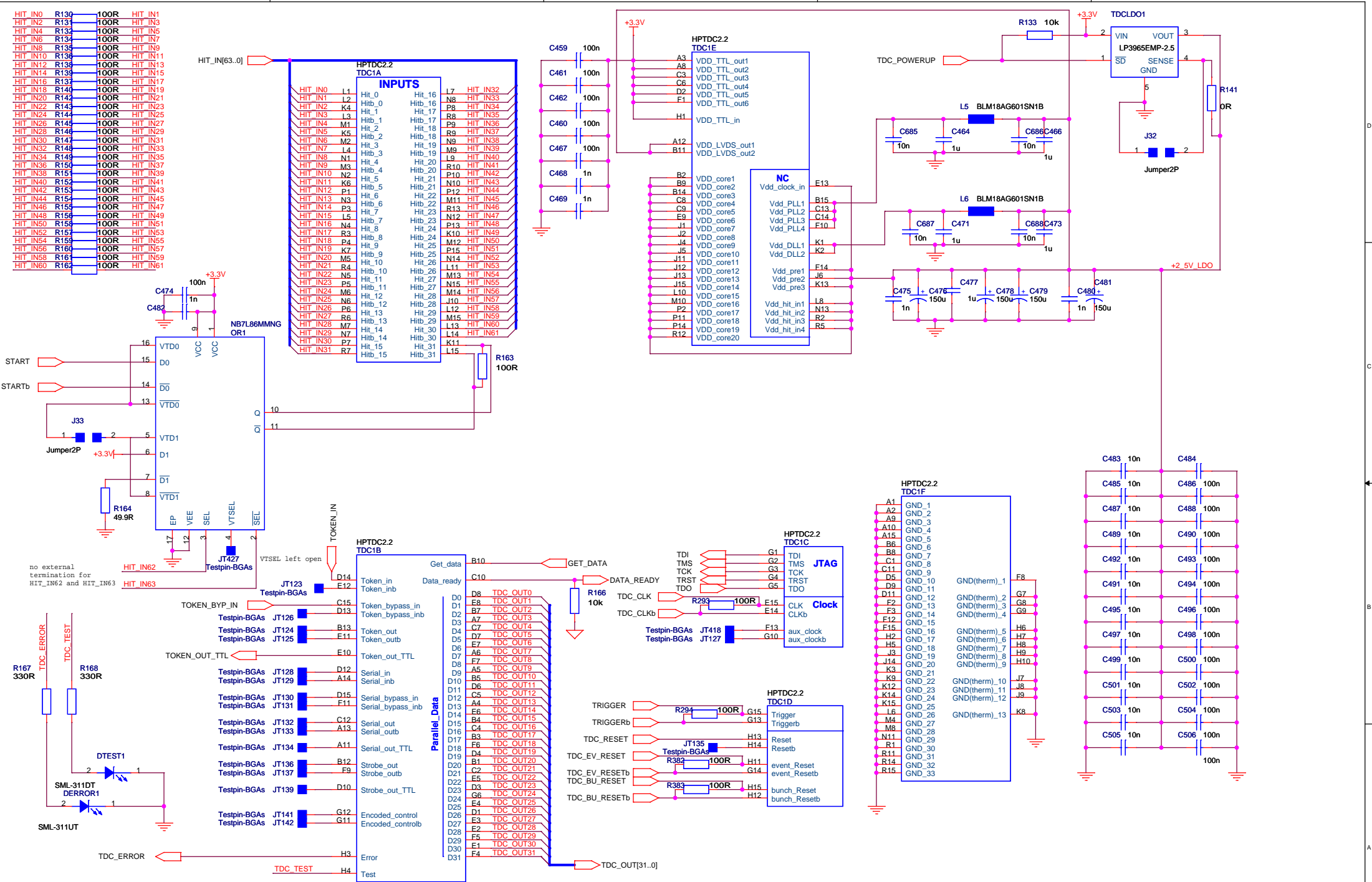

Title			TDC		
Size	Document Number	Rev			
A3	<Doc>	<Rev Code>			
Date:	Tuesday, February 13, 2007	Sheet	19	of	22

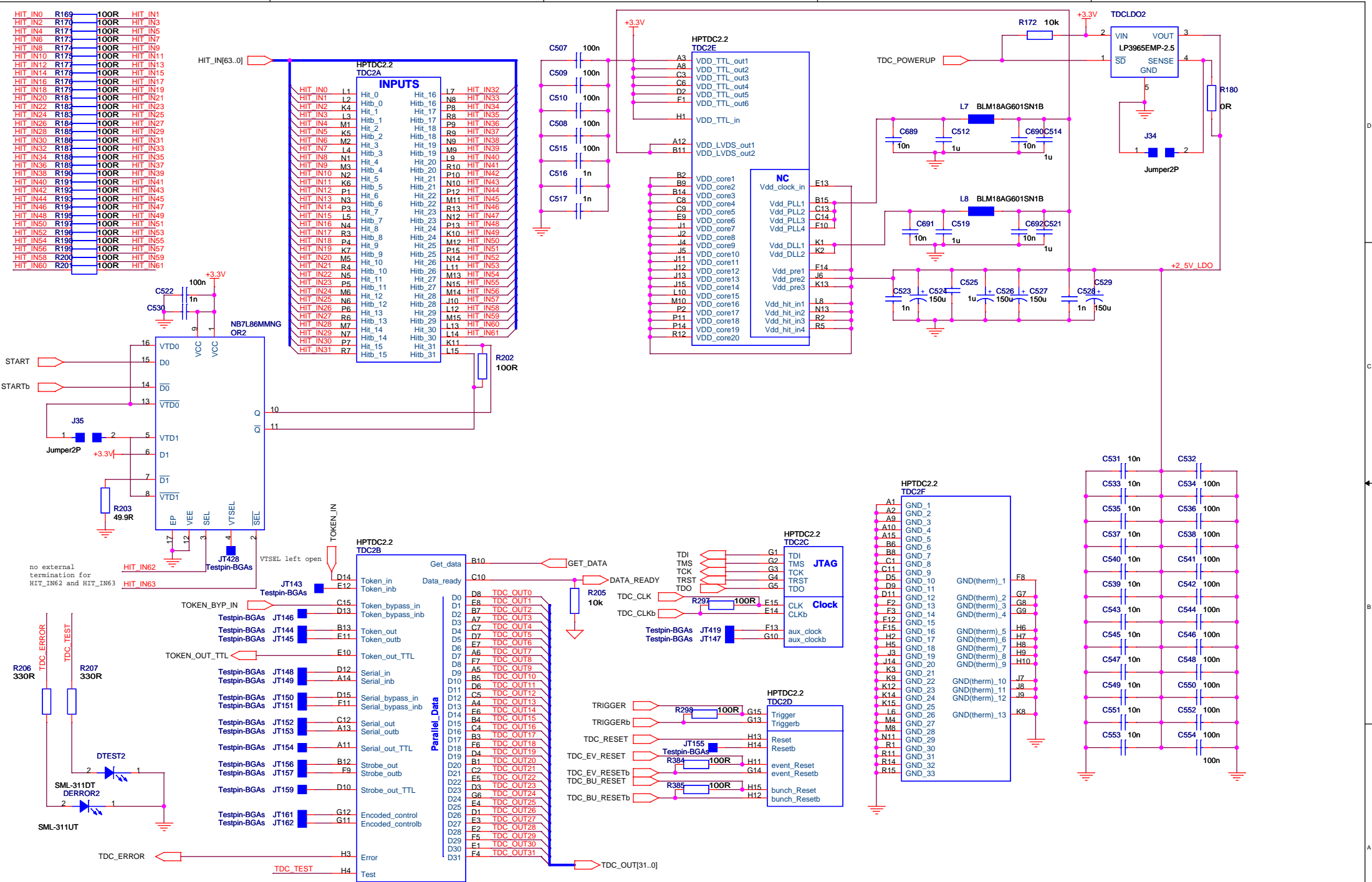

Title			TDC		
Size	Document Number	Rev			
A3	<Doc>	<Rev Code>			
Date:	Tuesday, February 13, 2007	Sheet	20	of	22

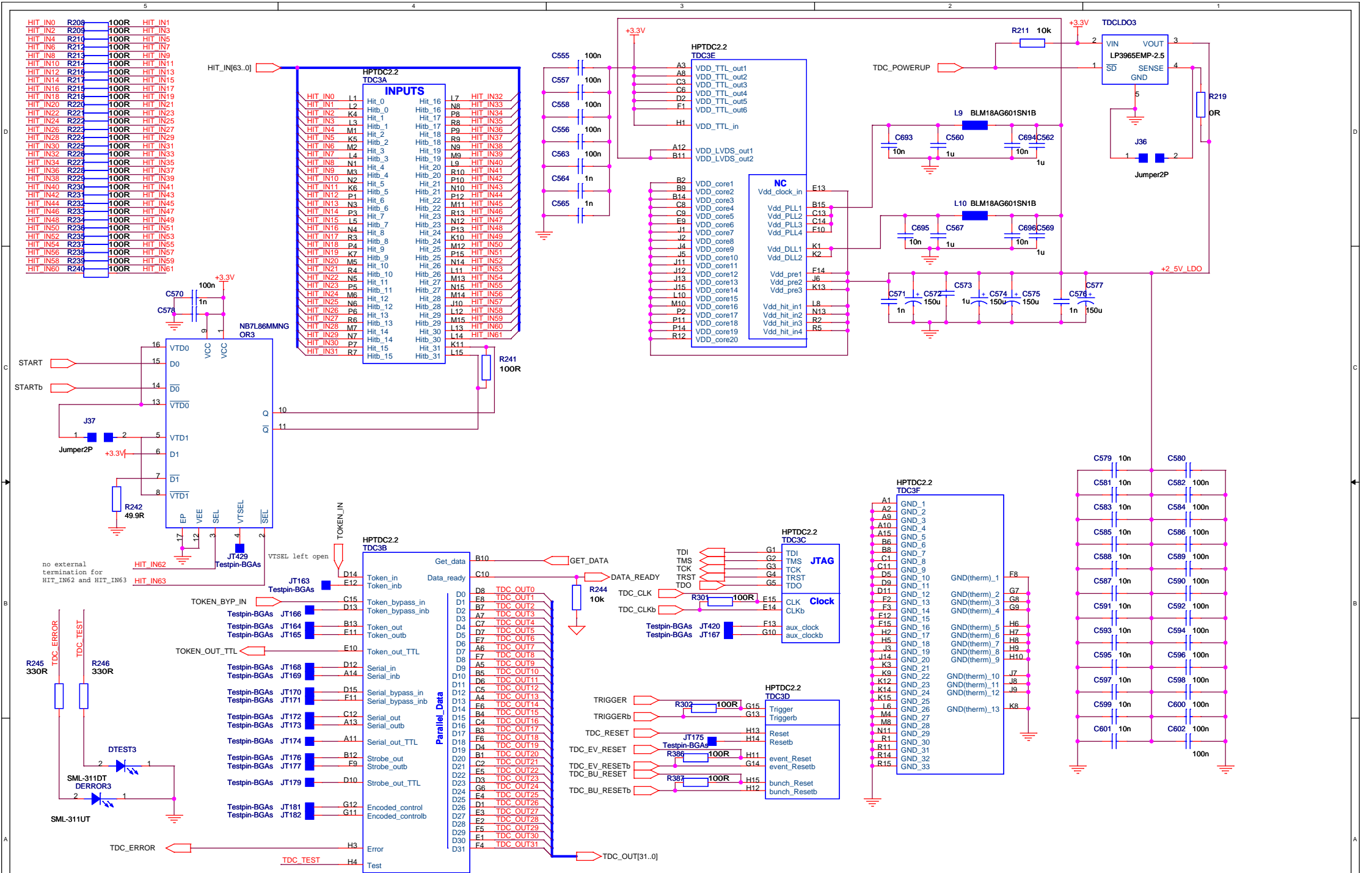

Title			<b>TDC</b>		
Size	Document Number	Rev			
A3	<Doc>	<Rev Code>			
Date:	Tuesday, February 13, 2007	Sheet	21	of	22



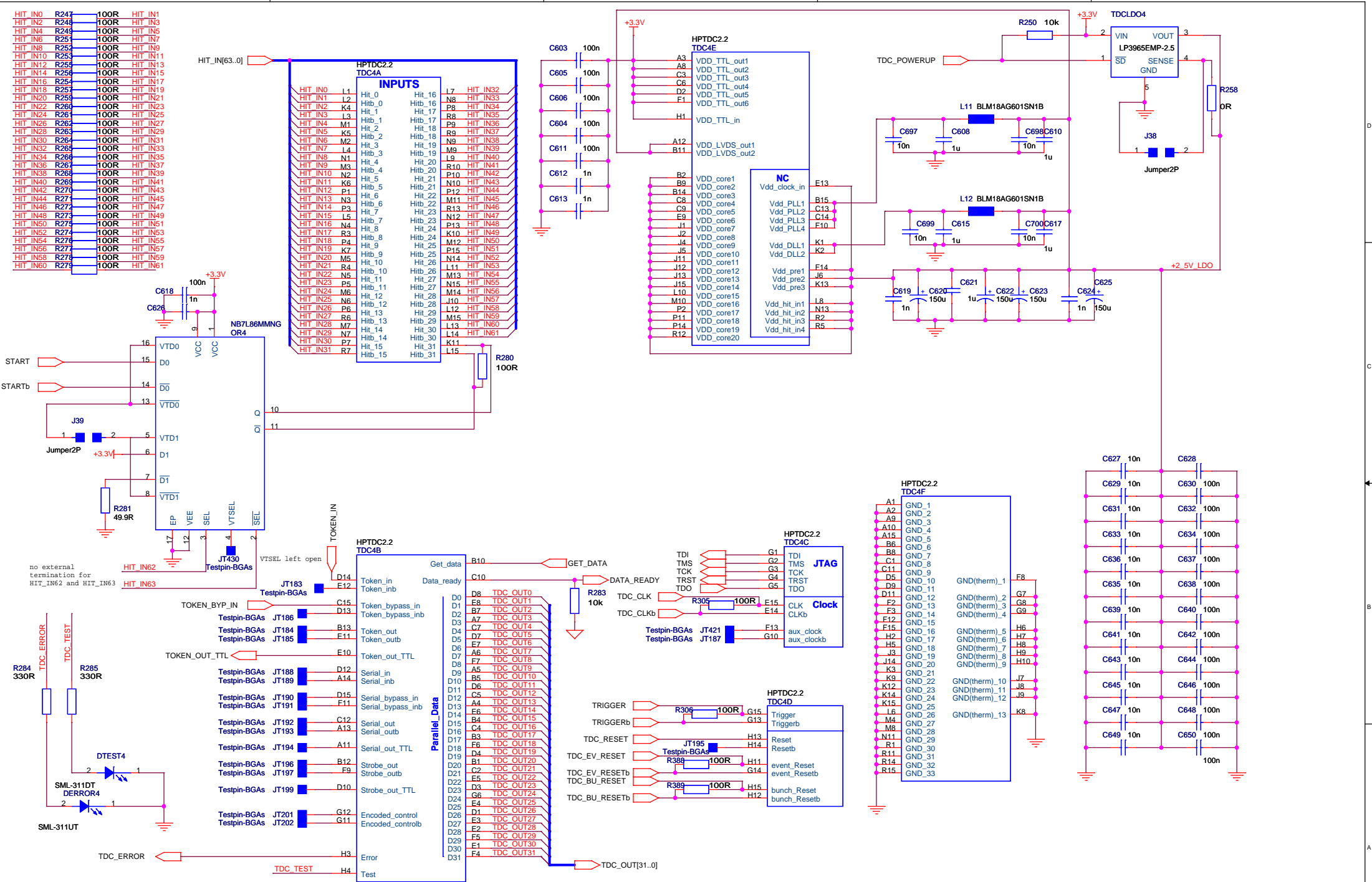

Title			<b>TDC</b>		
Size	Document Number	Rev			
A3	<Doc>	<Rev Code>			
Date:	Tuesday, February 13, 2007	Sheet	22	of	22



This document was created with Win2PDF available at <http://www.win2pdf.com>.  
The unregistered version of Win2PDF is for evaluation or non-commercial use only.  
This page will not be added after purchasing Win2PDF.