

Title			INPUT CHANNELS		
Size	Document Number				Rev
A3	<Doc>				<RevC>
Date:	Wednesday, December 06, 2006	Sheet	1	of	17

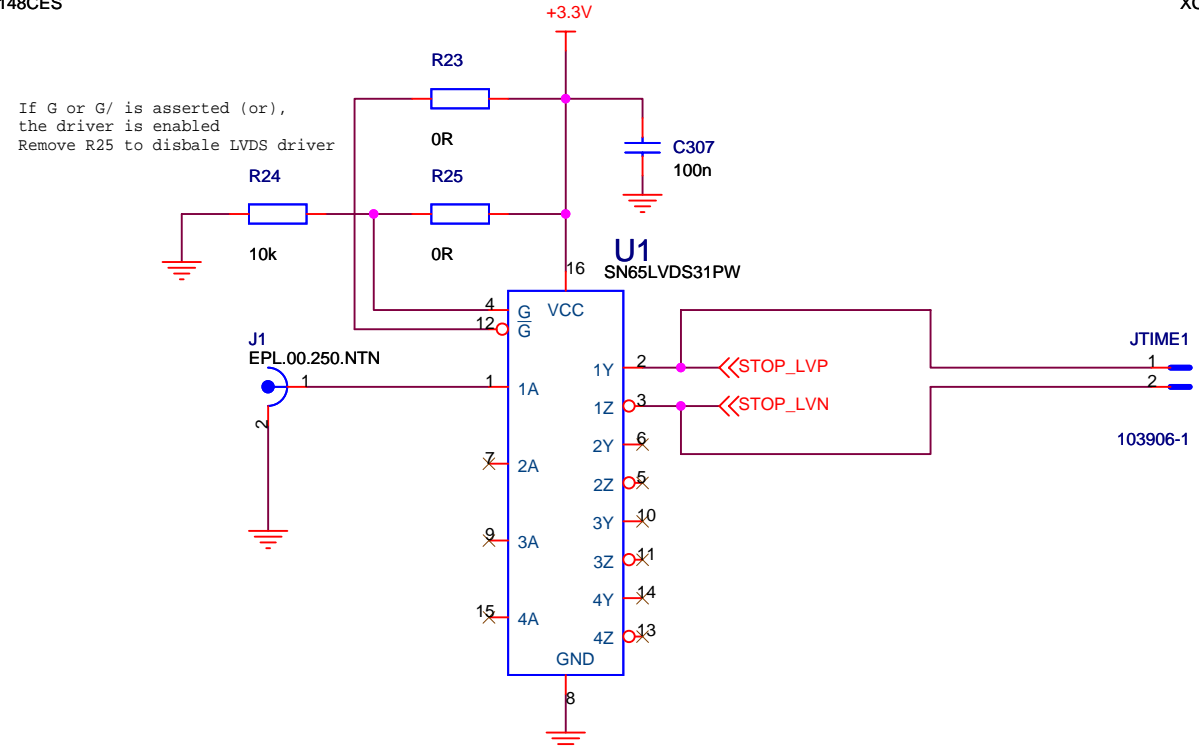

Title			VIRTEX PART A		
Size	Document Number	Rev			
A3	<Doc>	<RevC>			
Date:	Wednesday, December 06, 2006	Sheet	2	of	17

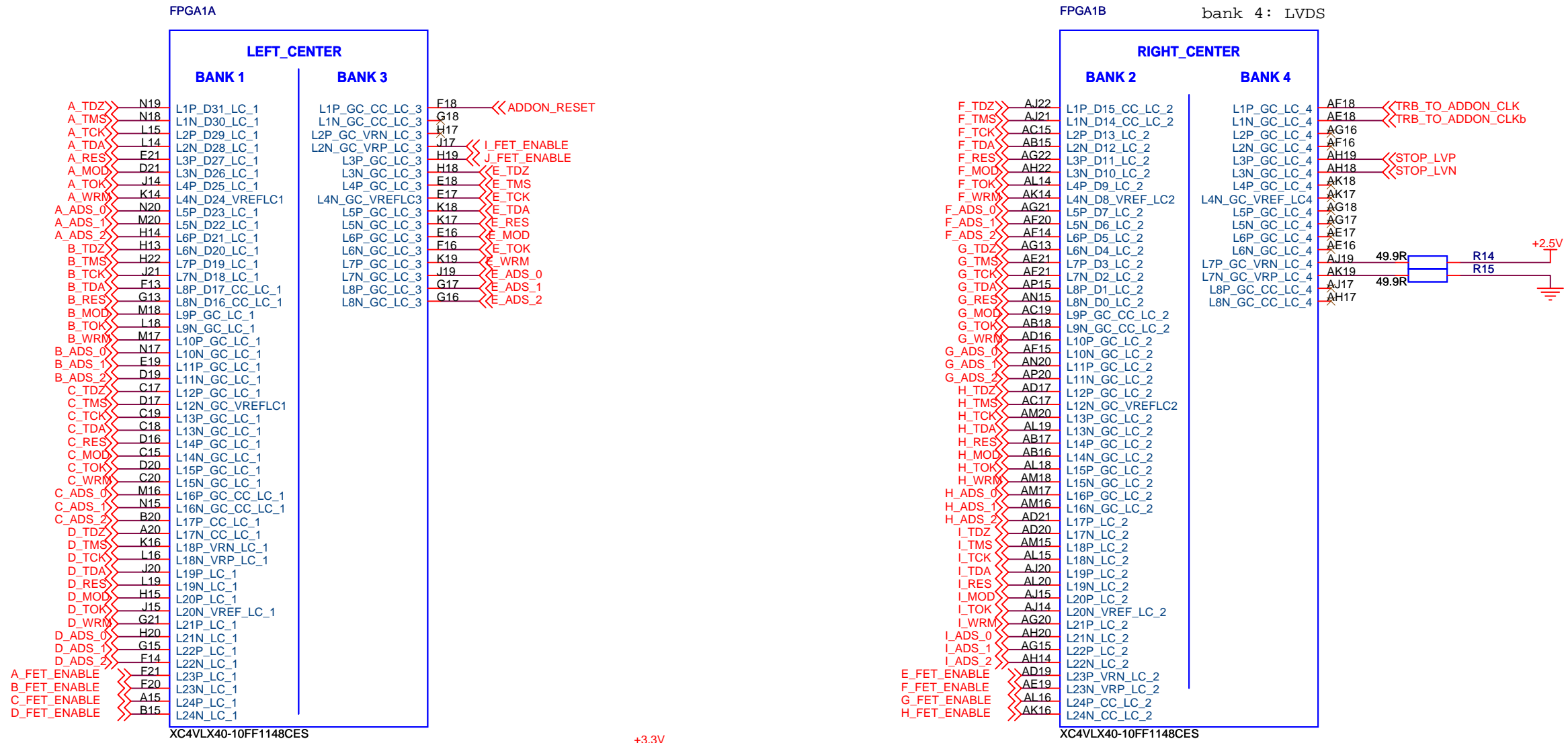

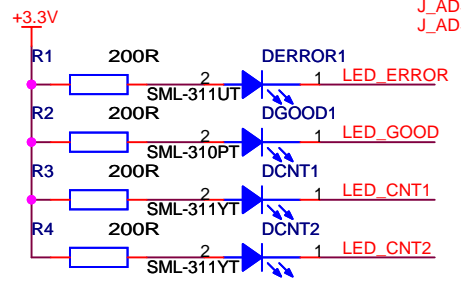
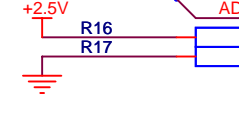
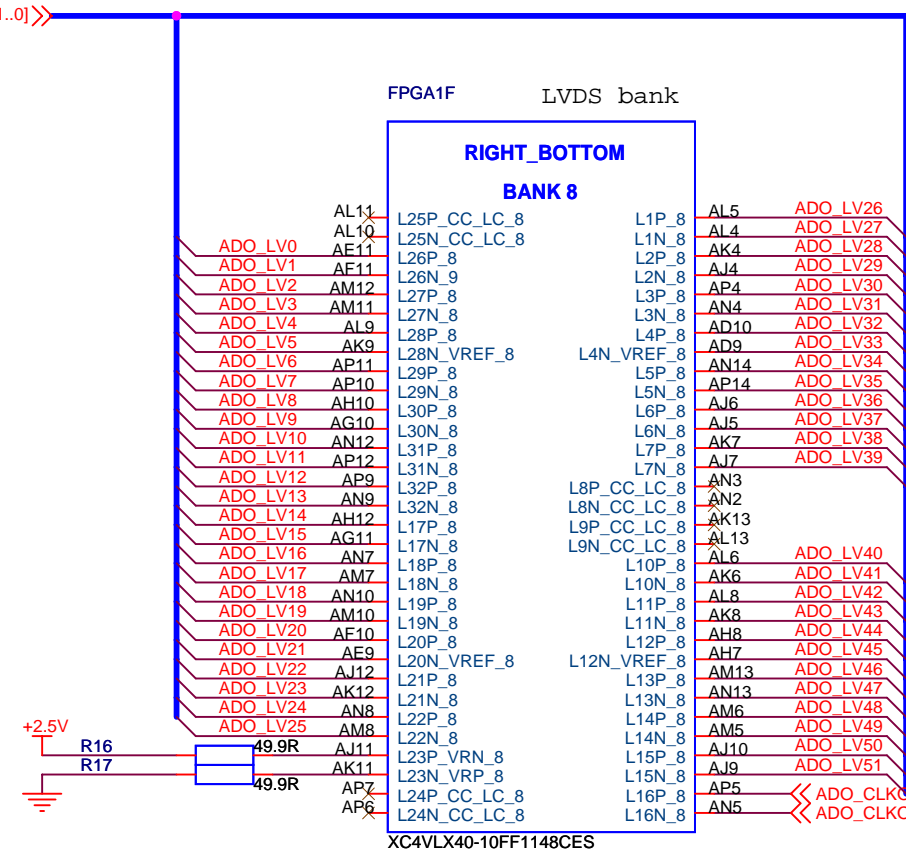
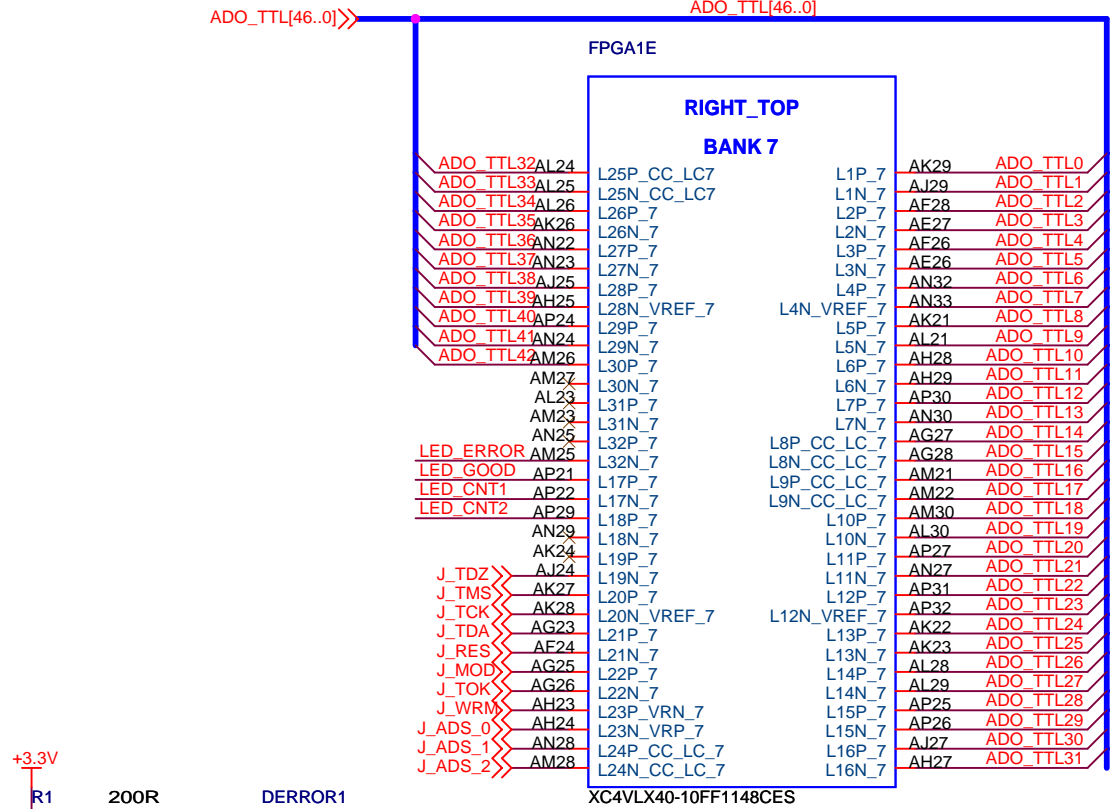
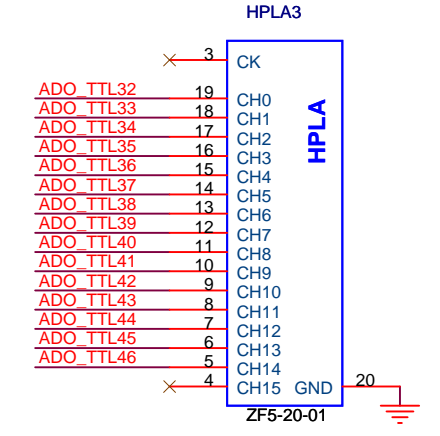
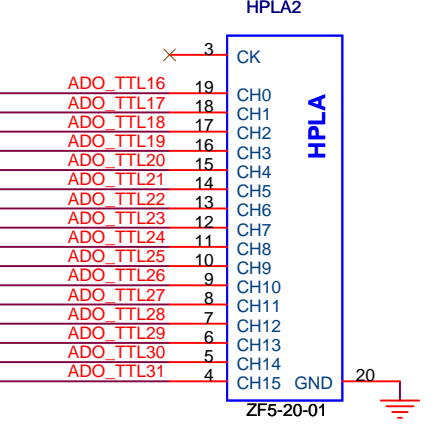
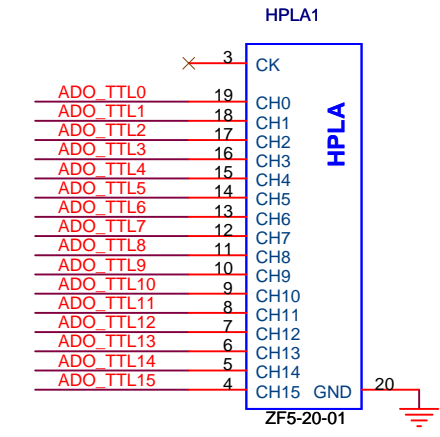
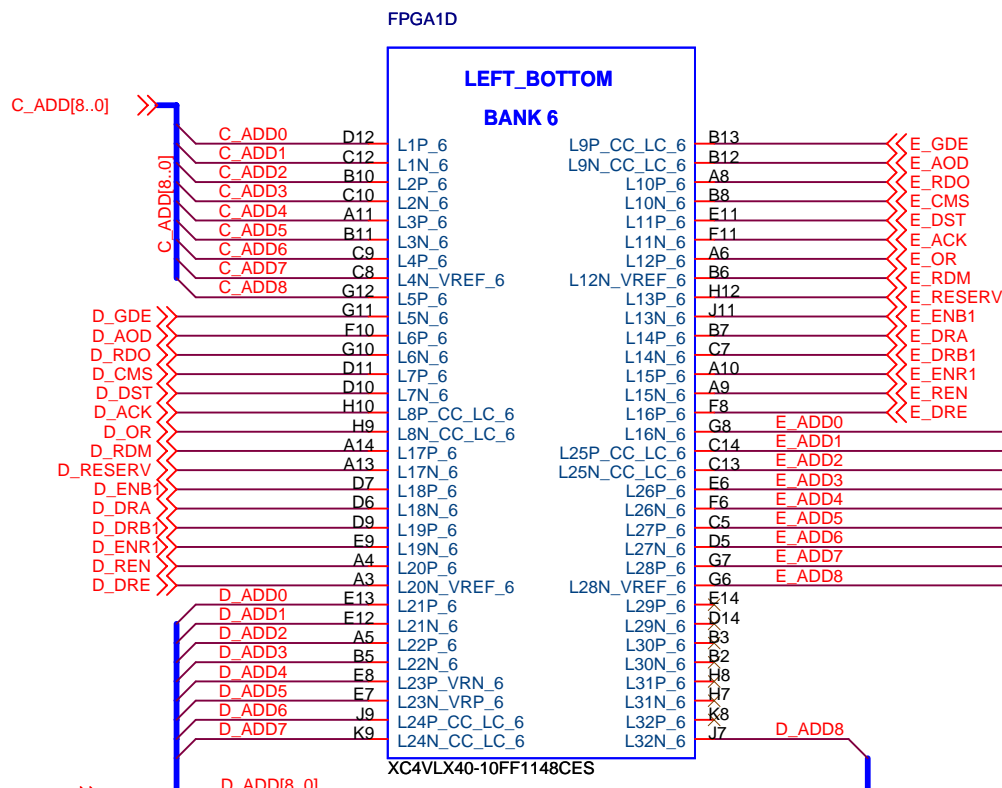
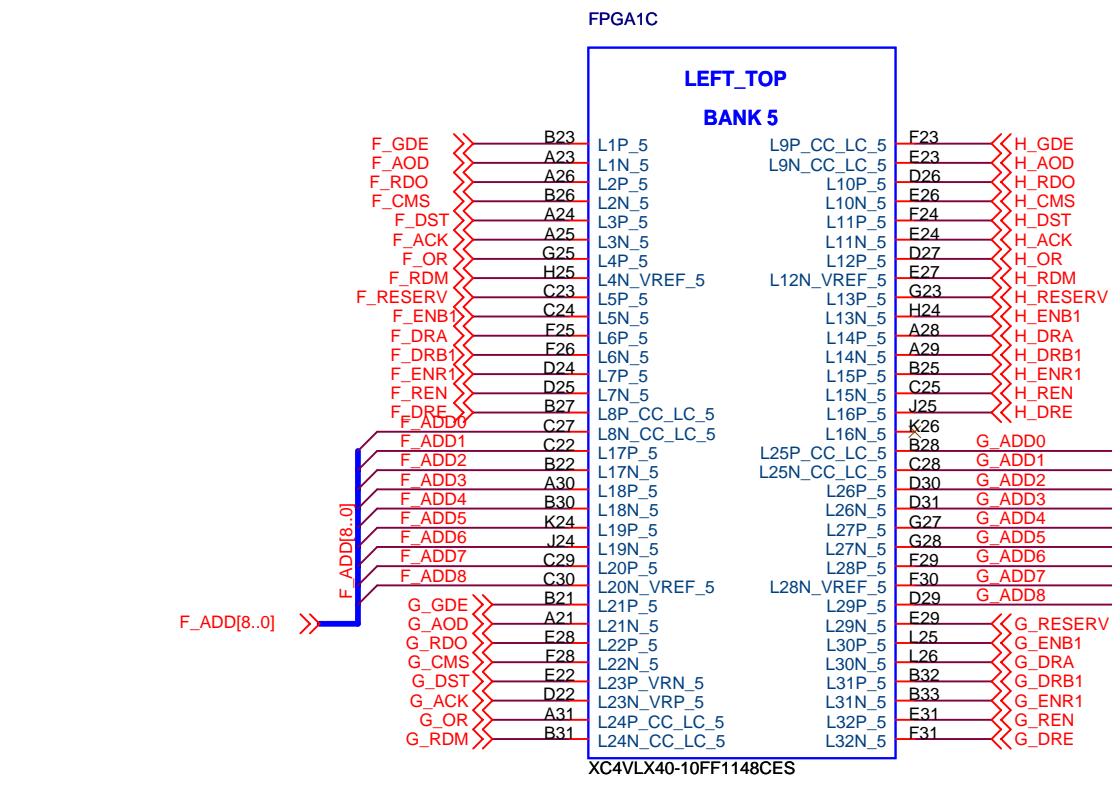
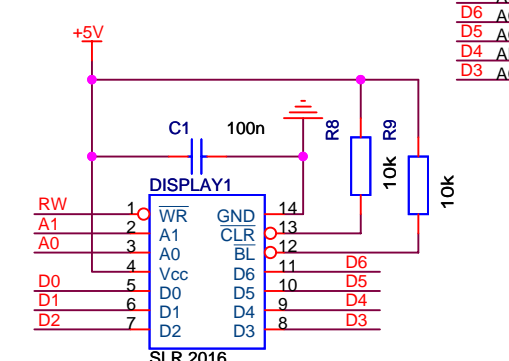
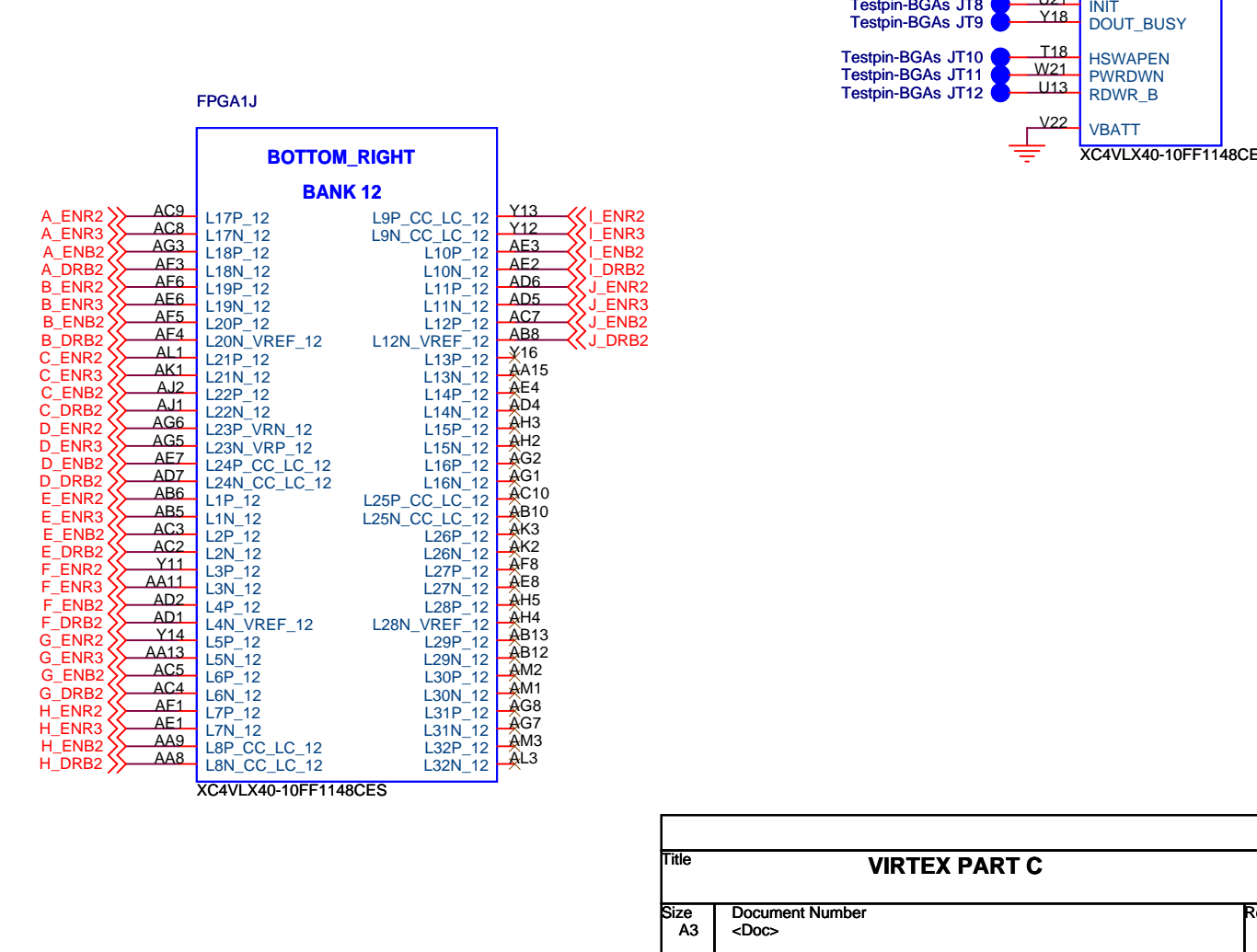
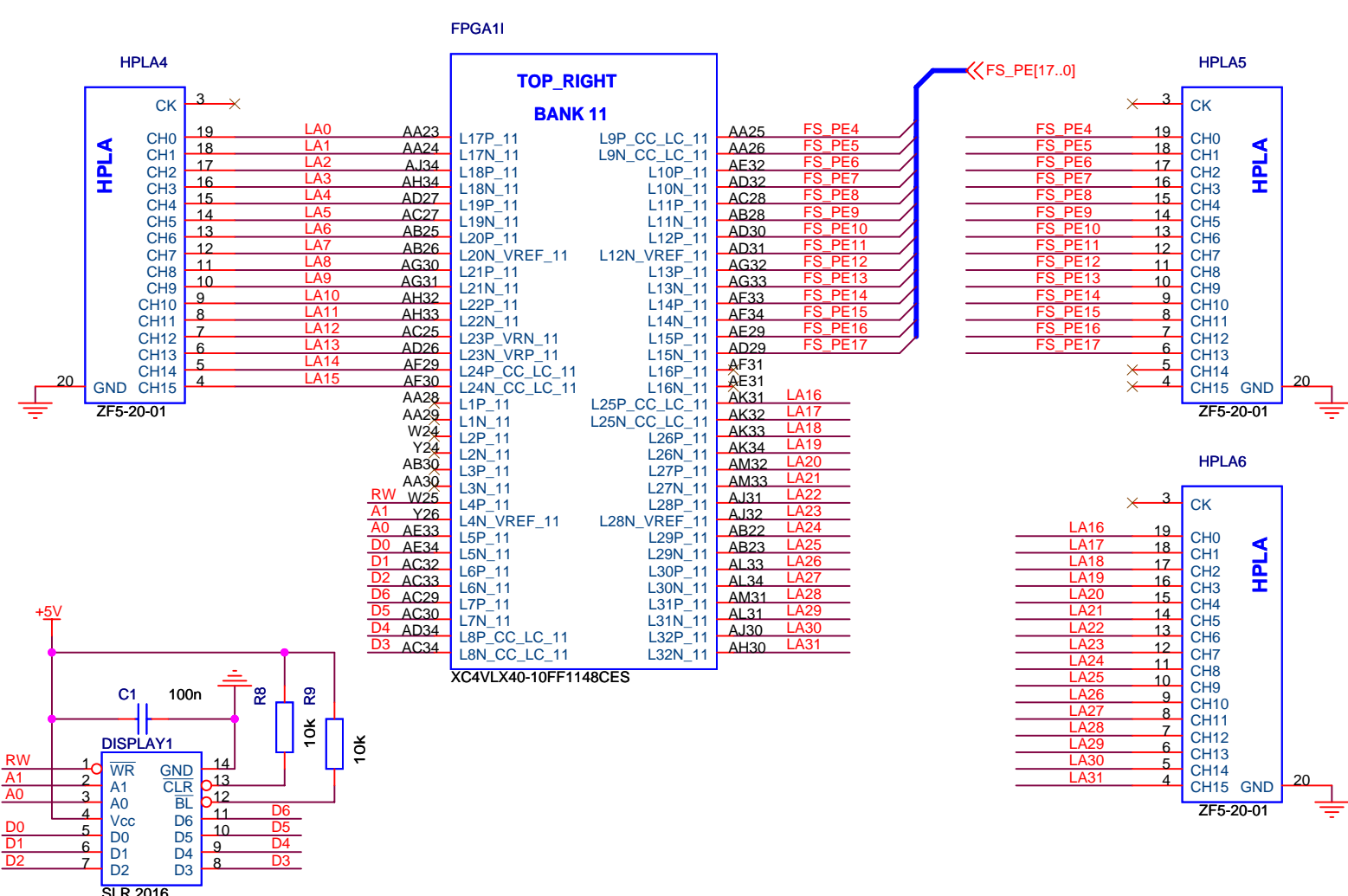
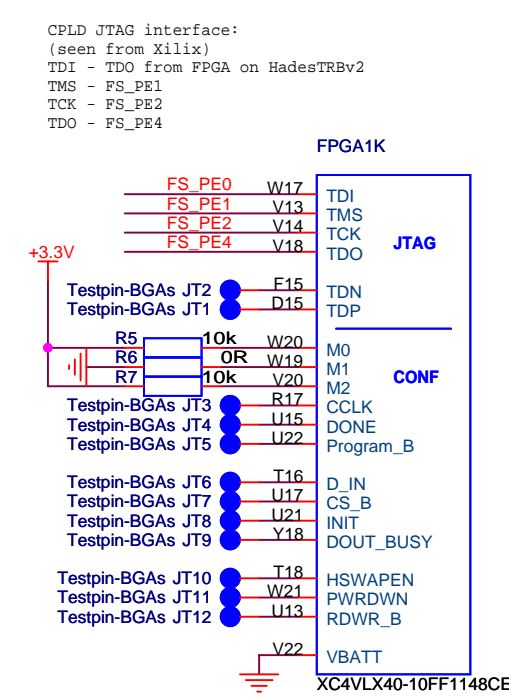
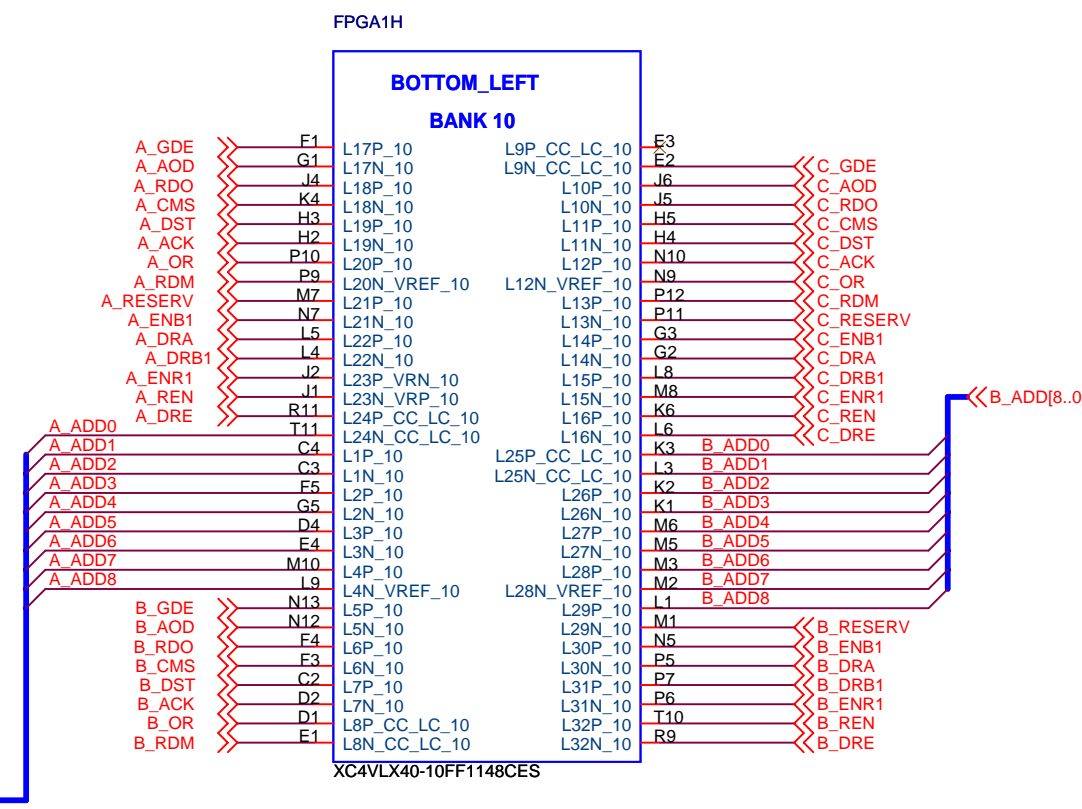
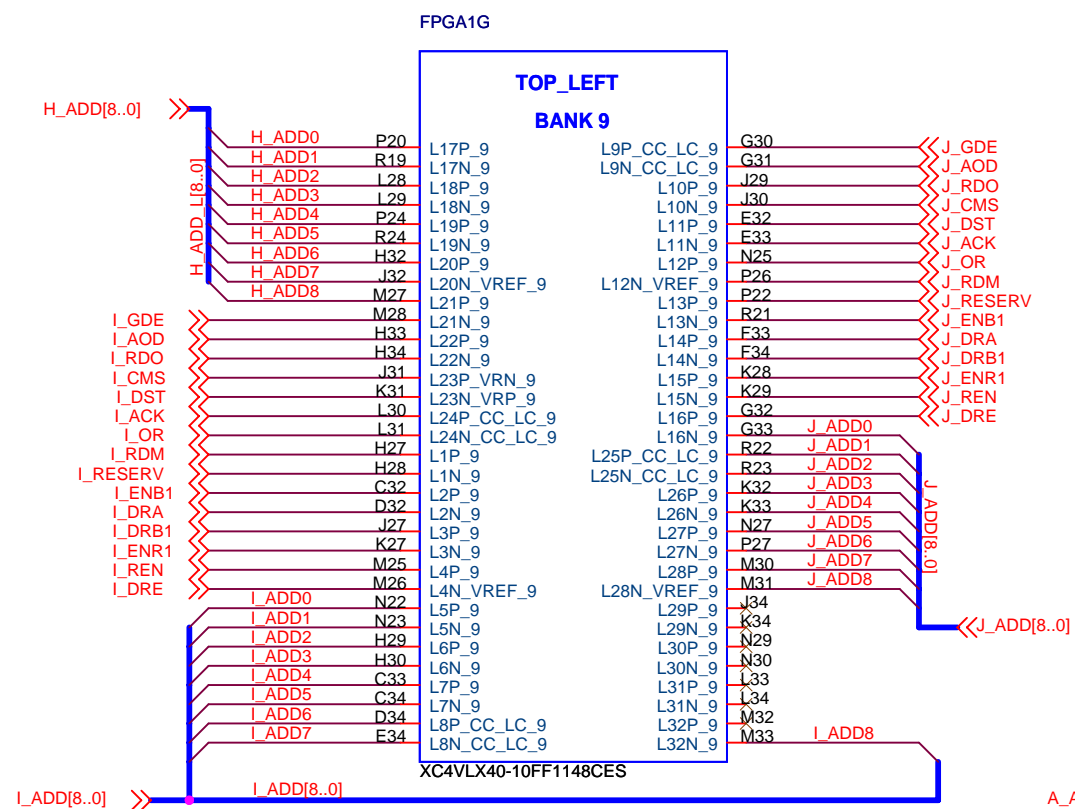

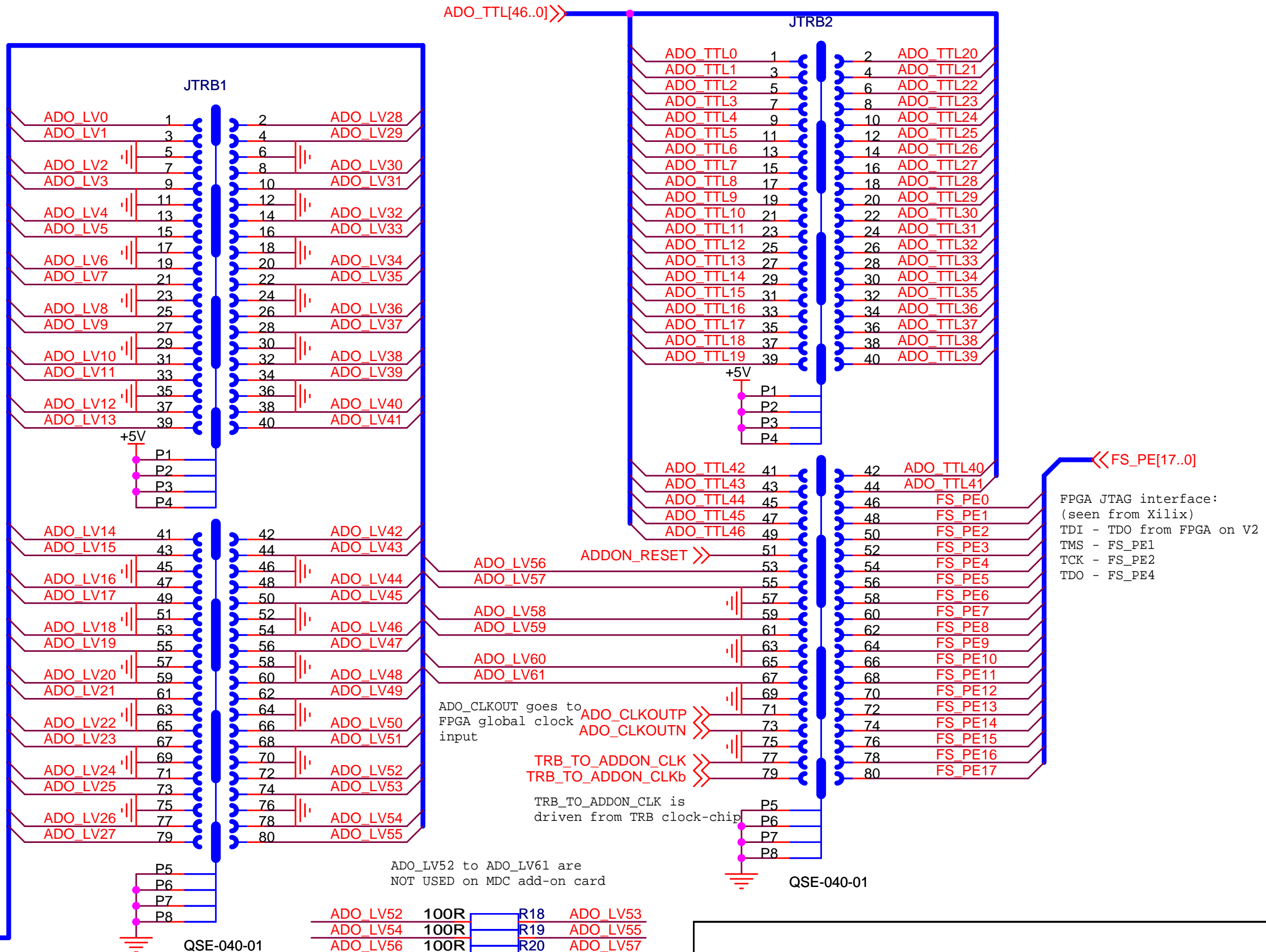

FPGA JTAG interface:
 (seen from Xilinx)
 TDI - TDO from FPGA on V2
 TMS - FS_PE1
 TCK - FS_PE2
 TDO - FS_PE4

ADO_LV52	100R	R18	ADO_LV53
ADO_LV54	100R	R19	ADO_LV55
ADO_LV56	100R	R20	ADO_LV57
ADO_LV58	100R	R21	ADO_LV59
ADO_LV60	100R	R22	ADO_LV61

Title			OUTPUT CONNECTORS		
Size	Document Number	Rev			
A	<Doc>	<RevCode>			
Date:	Wednesday, December 06, 2006	Sheet	5	of	17

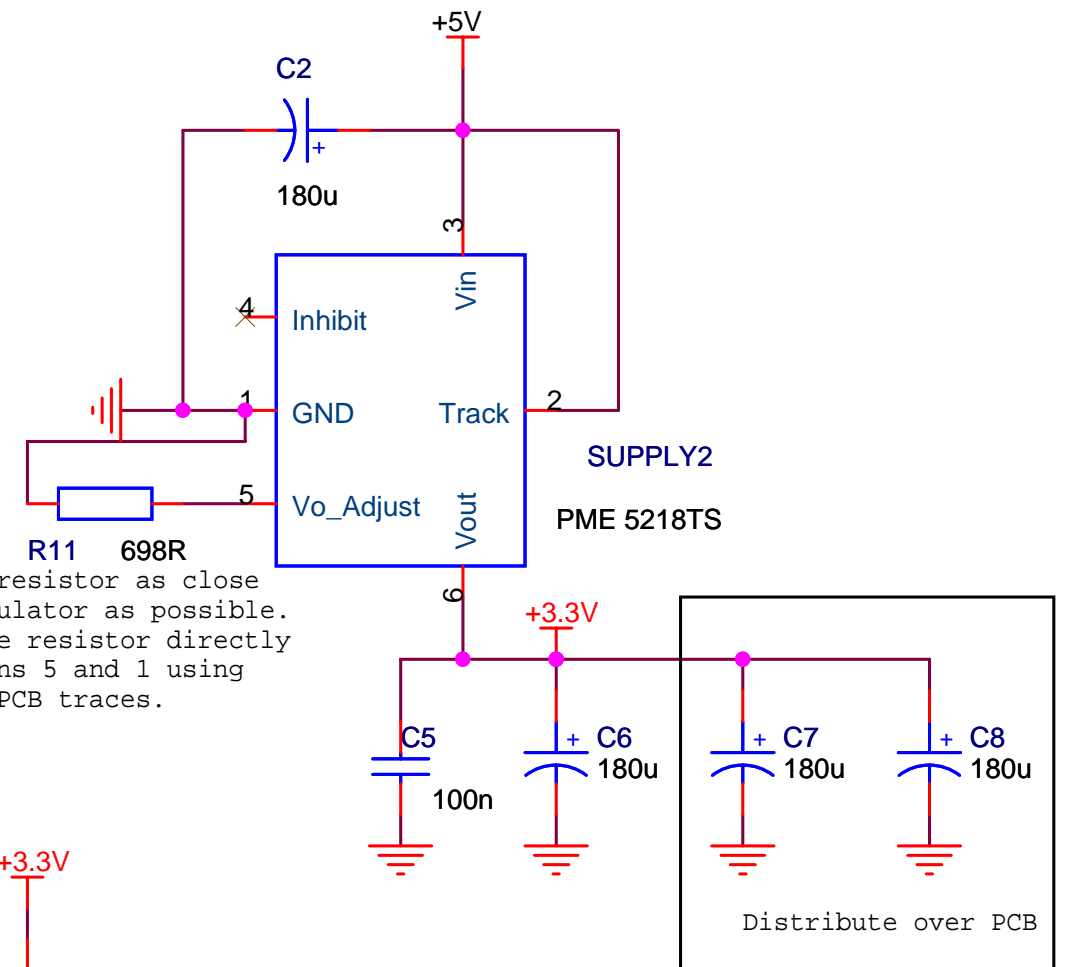

Place the resistor as close to the regulator as possible. Connect the resistor directly between pins 5 and 1 using dedicated PCB traces.

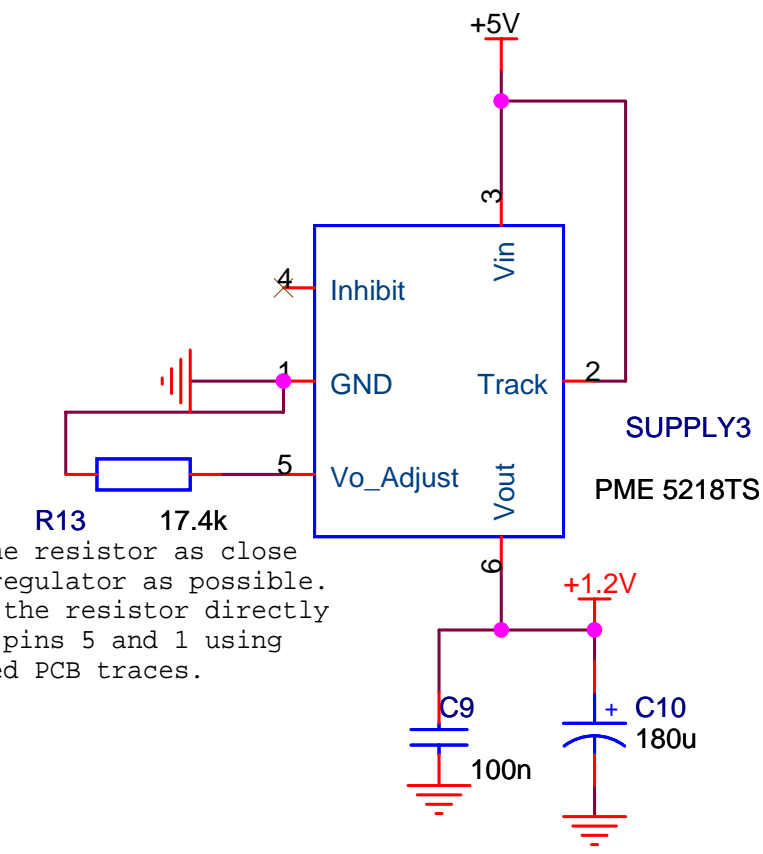
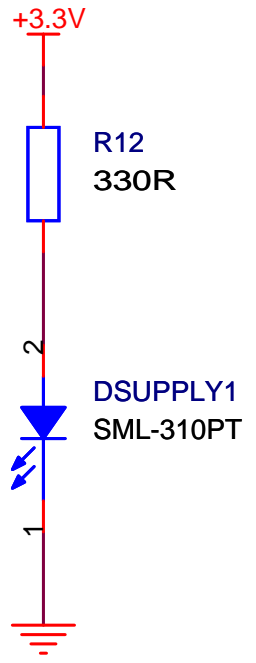

Place the resistor as close to the regulator as possible. Connect the resistor directly between pins 5 and 1 using dedicated PCB traces.

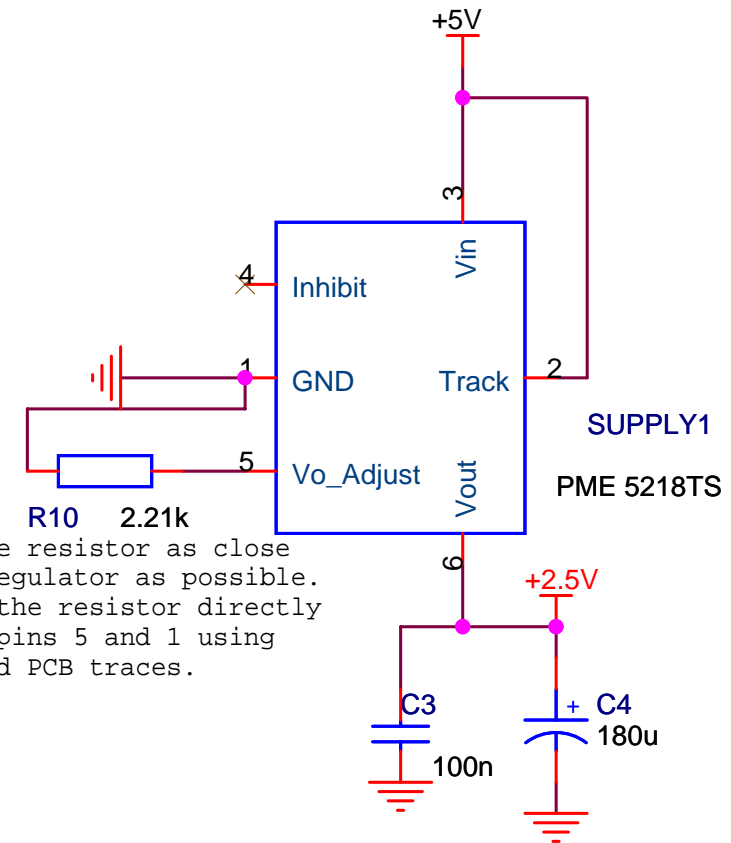
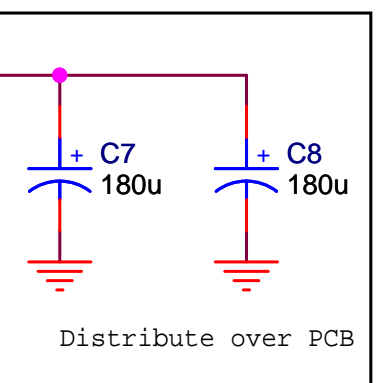

Place the resistor as close to the regulator as possible. Connect the resistor directly between pins 5 and 1 using dedicated PCB traces.

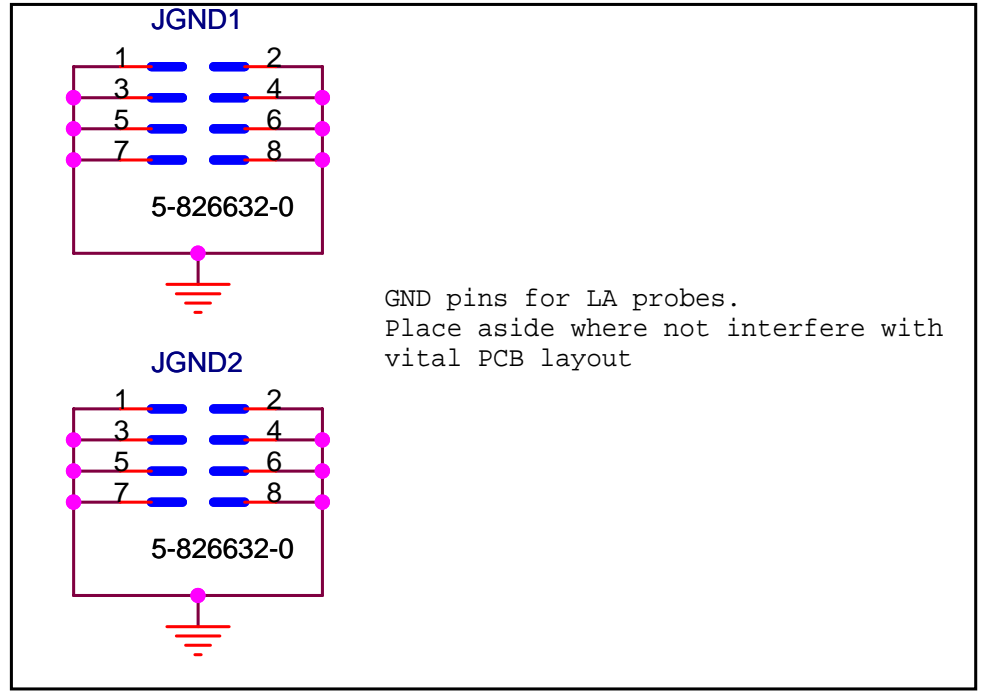

Title			POWER SUPPLY		
Size	Document Number	Rev			
A	<Doc>	<RevCode>			
Date:	Wednesday, December 06, 2006	Sheet	6	of	17

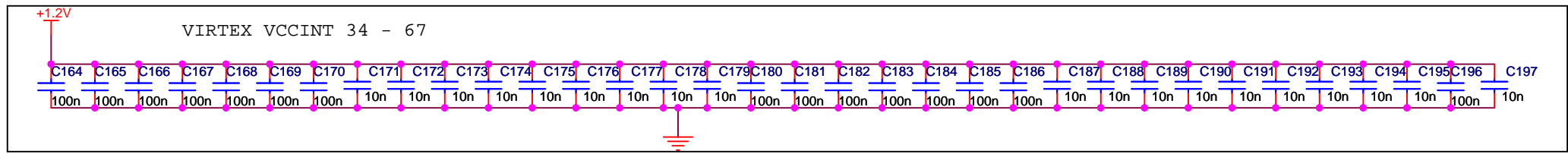
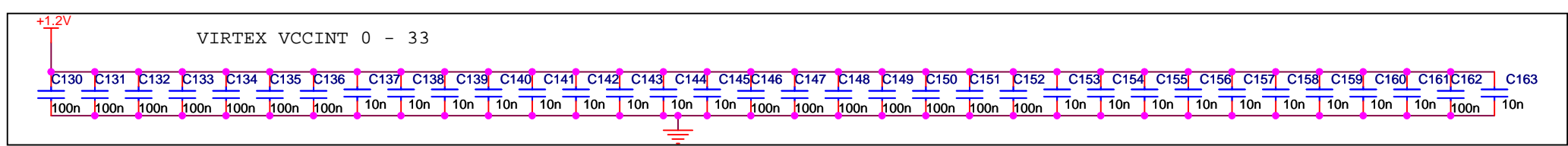
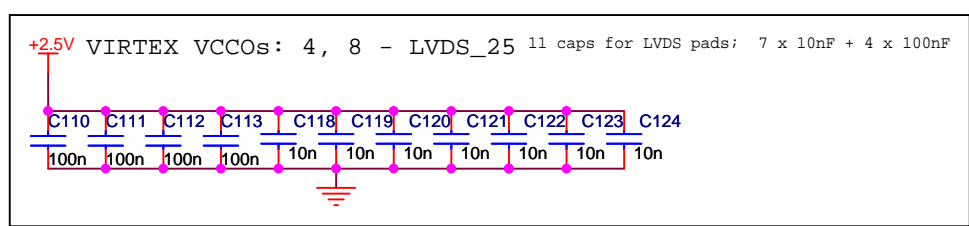
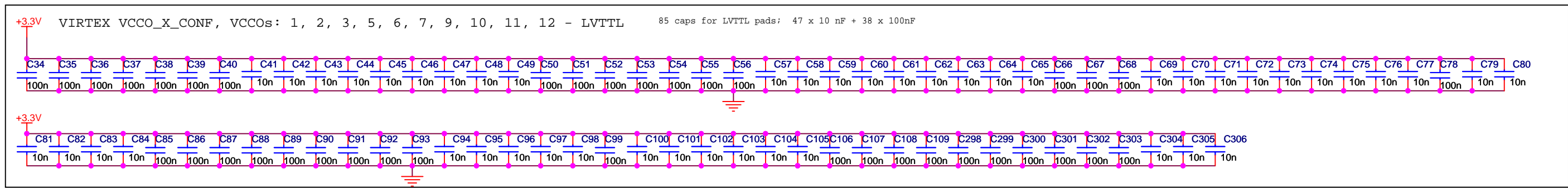
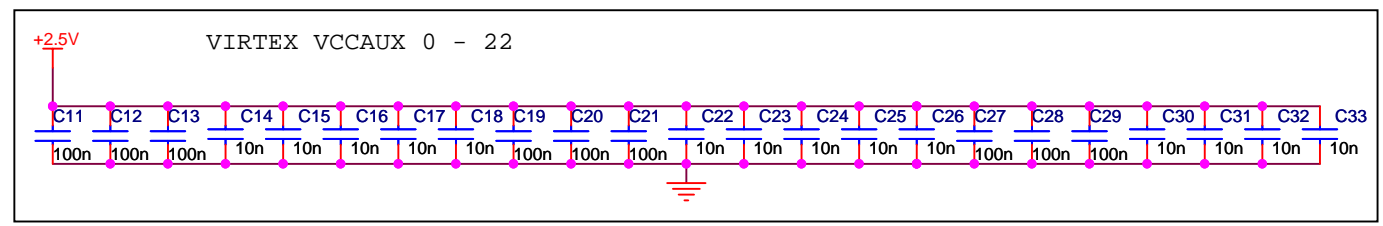
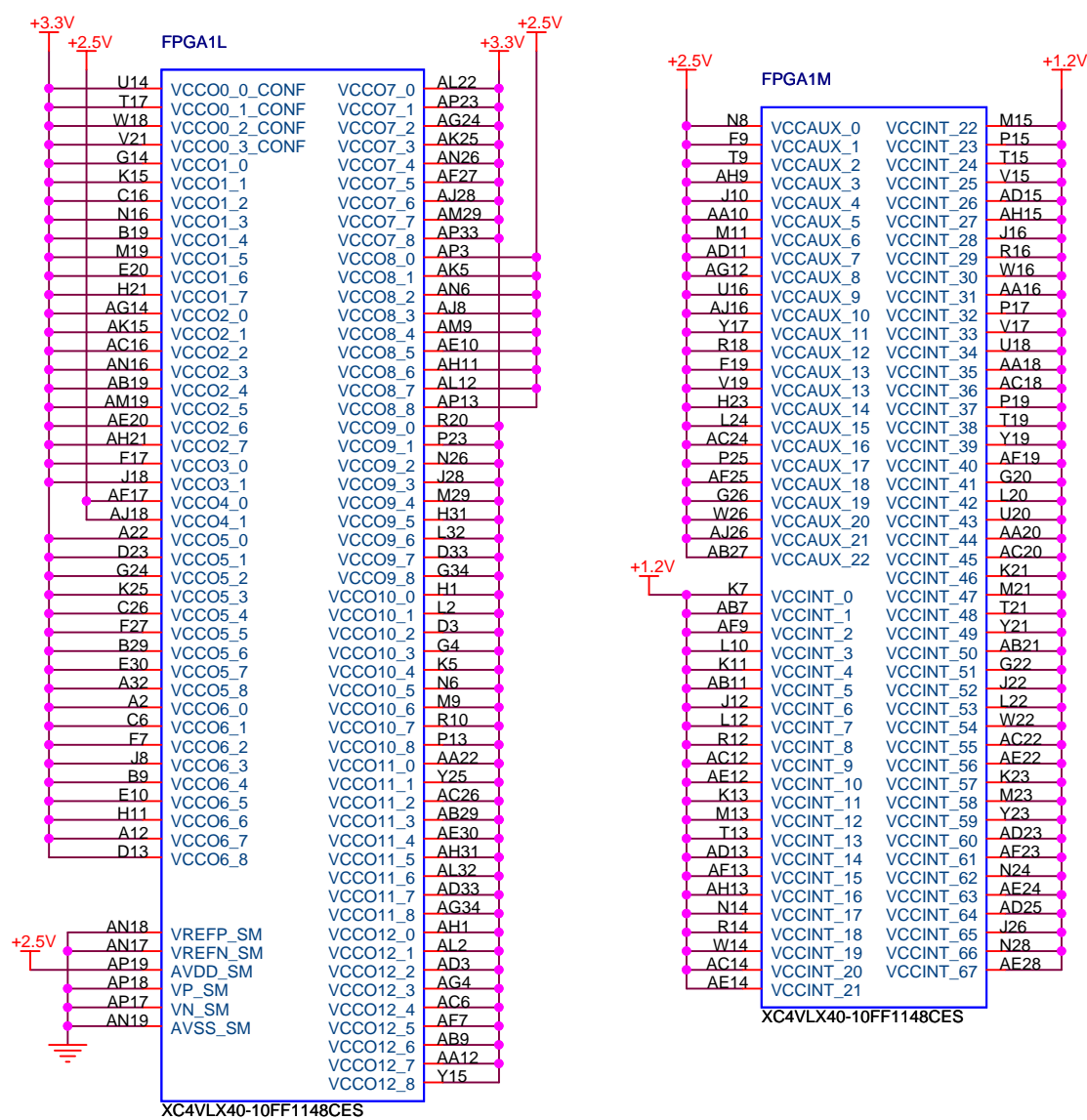

Title			VIRTEX SUPPLY		
Size	Document Number				Rev
A3	<Doc>				<RevC>
Date:	Wednesday, December 06, 2006	Sheet	7	of	17

ERNI-063210
JINPUT1

TDA	H	1	2	TDA	C
TMS	C	3	4	TCK	C
RES	C	5	6	TOK	C
MOD	C	7	8	WRM	C
GD+	9	10	GD-		
AD+	11	12	AD-		
RO+	13	14	RO-		
CM+	15	16	CM-		
DS+	17	18	DS-		
AC+	19	20	AC-		
AS0	21	22			
AS1	23	24			
AS2	25	26			
RM+	27	28	RM-		
OR+	29	30	OR-		
D0+	31	32	D0-		
D1+	33	34	D1-		
D2+	35	36	D2-		
D3+	37	38	D3-		
D4+	39	40	D4-		
D5+	41	42	D5-		
D6+	43	44	D6-		
D7+	45	46	D7-		
D8+	47	48	D8-		
RS+	49	50	RS-		

TDA - out
TMS - out
TCK - out
TDZ - in

RES - out
TOK - out
MOD - out
WRM - out
ADS - I/O

GDE - out only
CMS - out only
RDM - out only

DE/RE*
LOW: B to A
HIGH: A to B

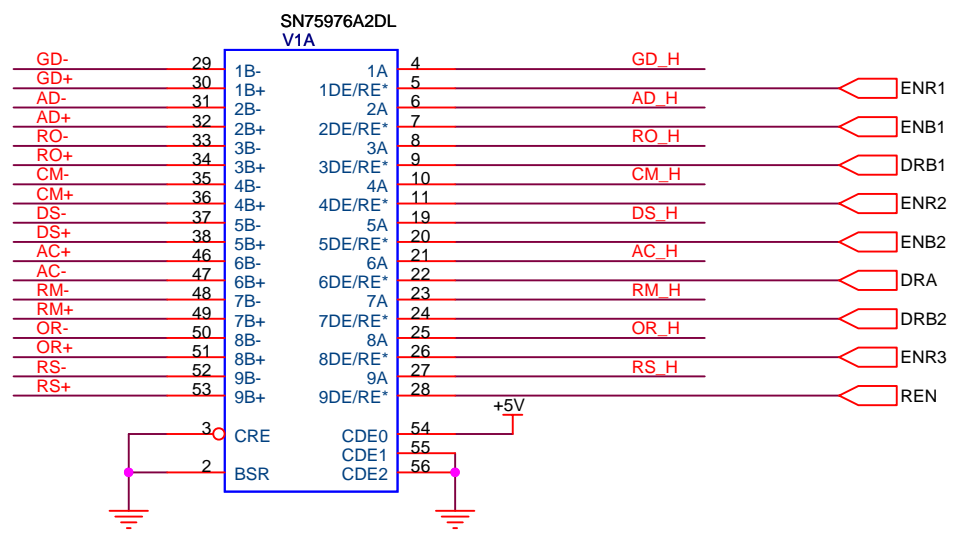

DE/RE*
LOW: B to A
HIGH: A to B

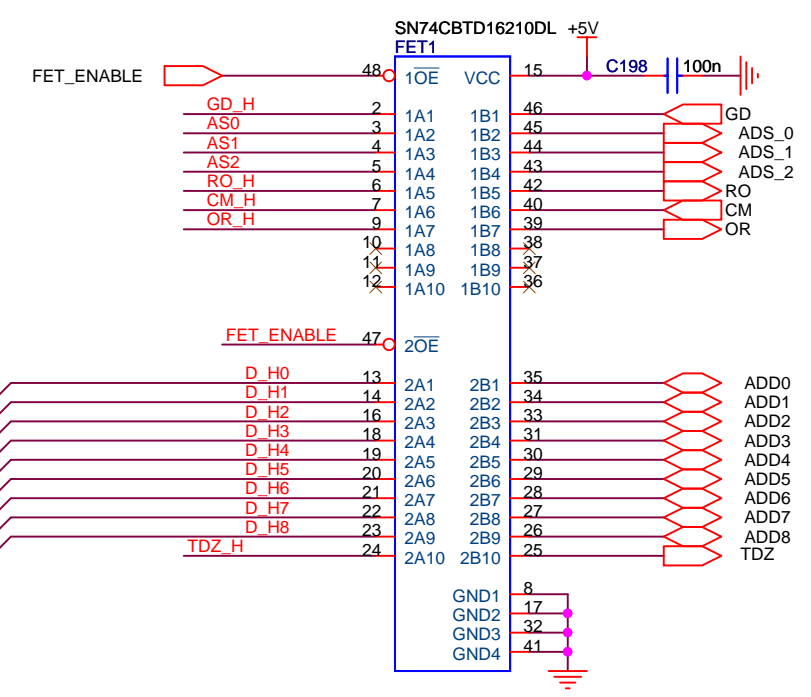
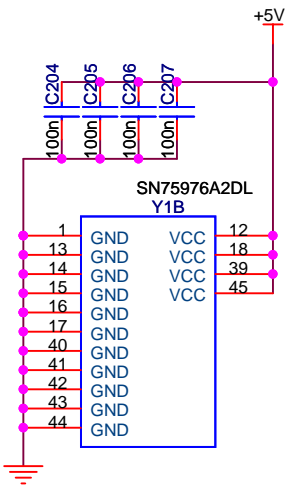
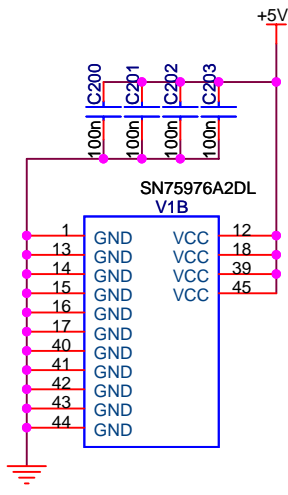
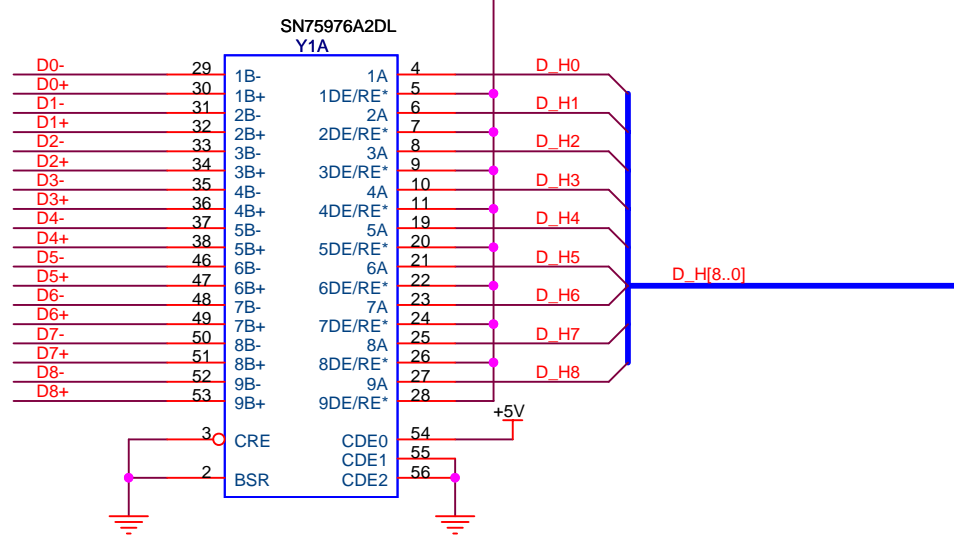

TDA - out
TMS - out
TCK - out
TDZ - in

RES - out
TOK - out
MOD - out
WRM - out
ADS - I/O

GDE - out only
CMS - out only
RDM - out only

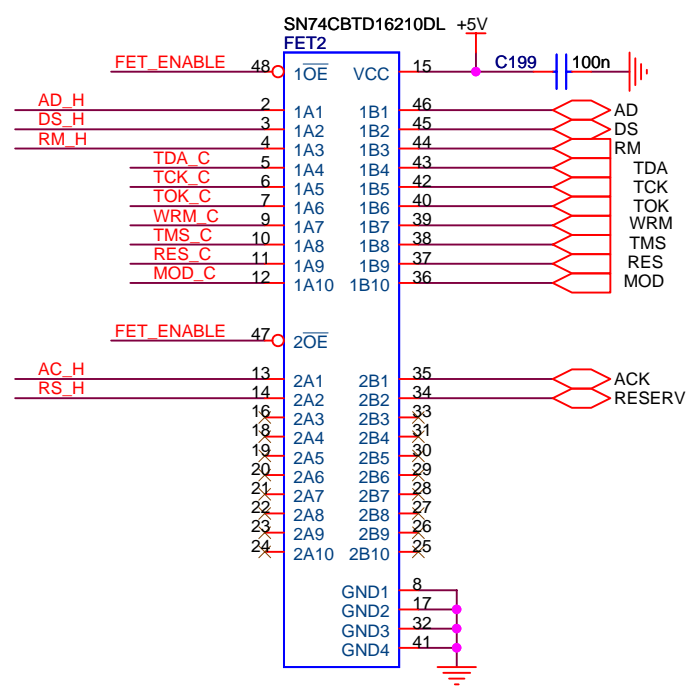

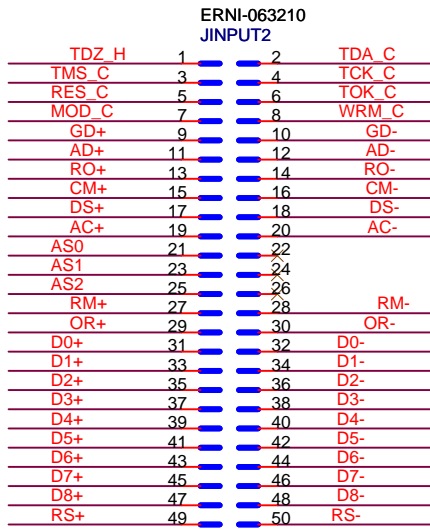

TDA - out
TMS - out
TCK - out
TDZ - in

RES - out
TOK - out
MOD - out
WRM - out
ADS - I/O

GDE - out only
CMS - out only
RDM - out only

DE/RE*
LOW: B to A
HIGH: A to B

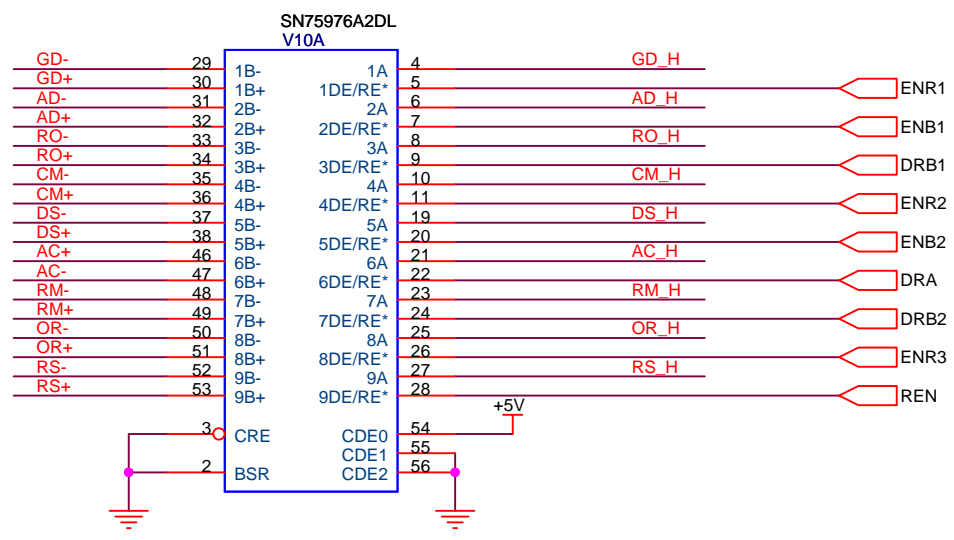

DE/RE*
LOW: B to A
HIGH: A to B

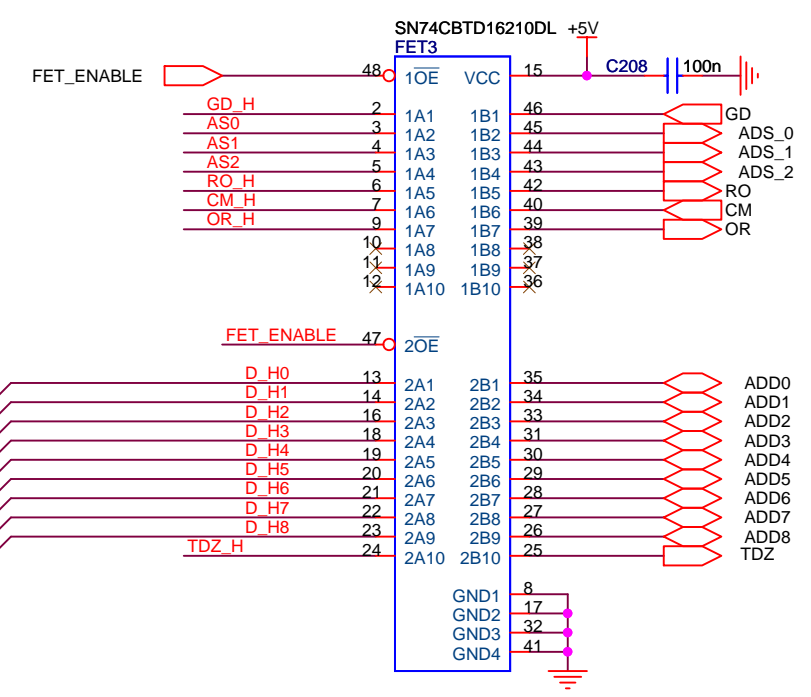
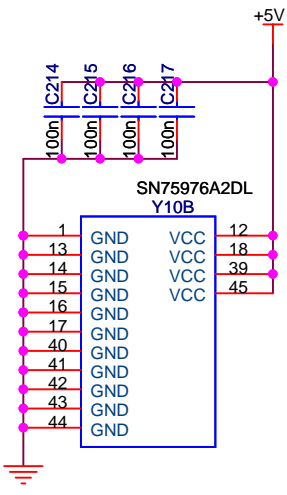
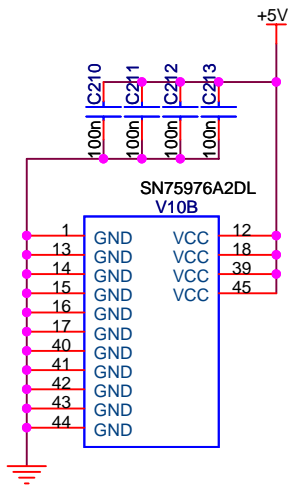
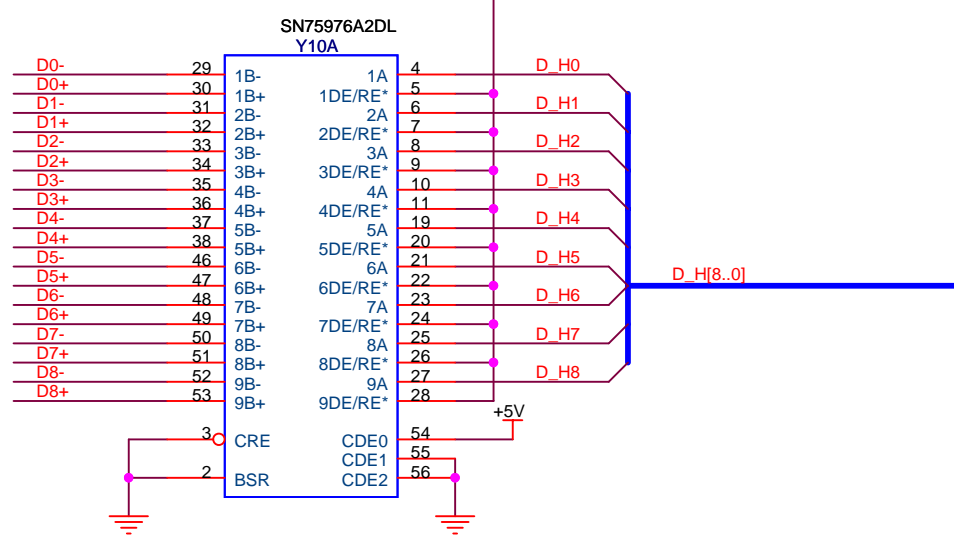

TDA - out
TMS - out
TCK - out
TDZ - in

RES - out
TOK - out
MOD - out
WRM - out
ADS - I/O

GDE - out only
CMS - out only
RDM - out only

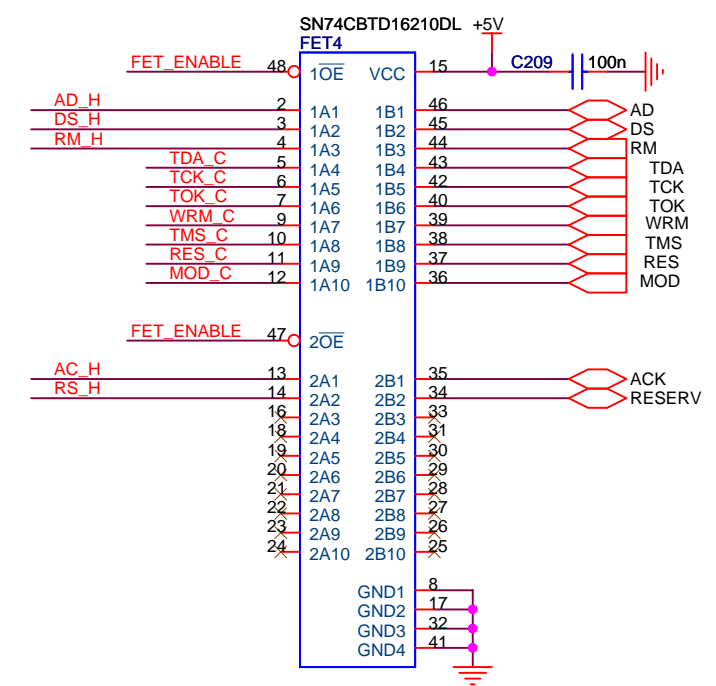

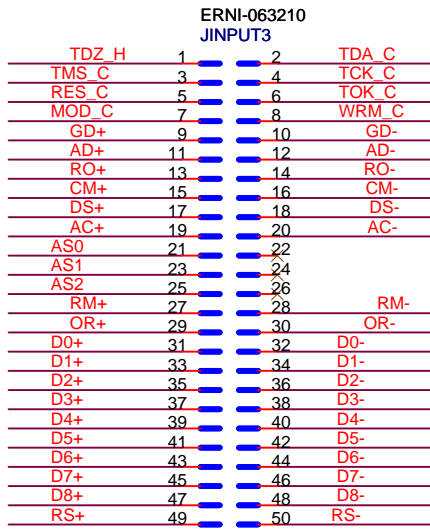

TDA - out
TMS - out
TCK - out
TDZ - in

RES - out
TOK - out
MOD - out
WRM - out
ADS - I/O

GDE - out only
CMS - out only
RDM - out only

DE/RE*
LOW: B to A
HIGH: A to B

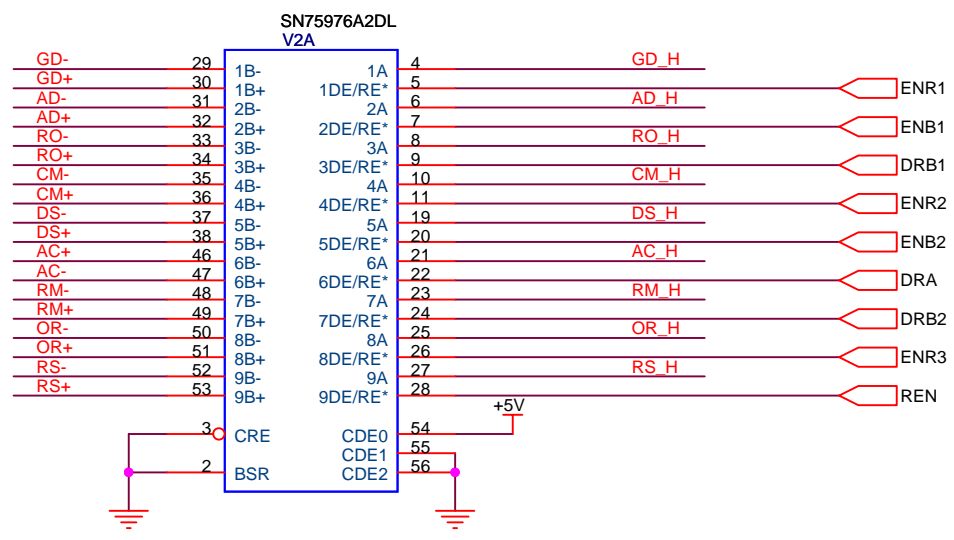

DE/RE*
LOW: B to A
HIGH: A to B

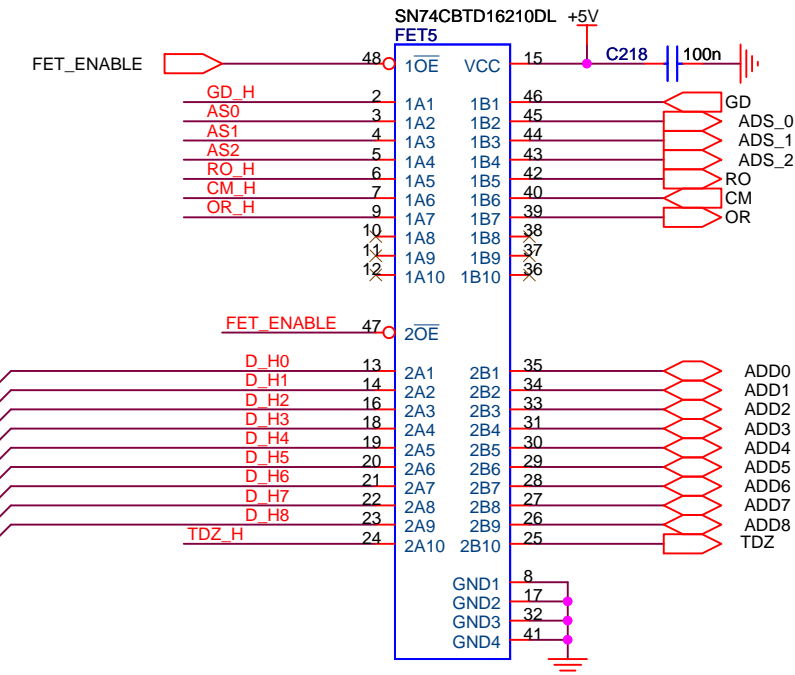
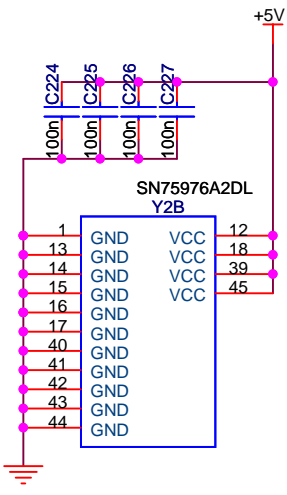
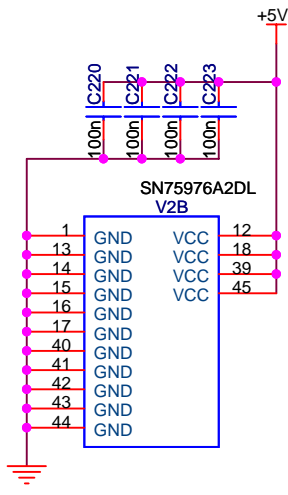
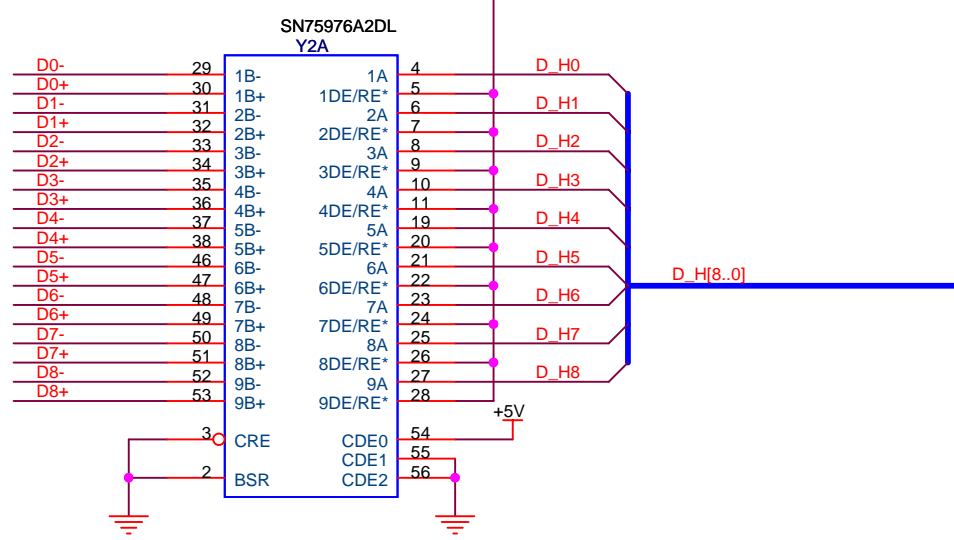

TDA - out
TMS - out
TCK - out
TDZ - in

RES - out
TOK - out
MOD - out
WRM - out
ADS - I/O

GDE - out only
CMS - out only
RDM - out only

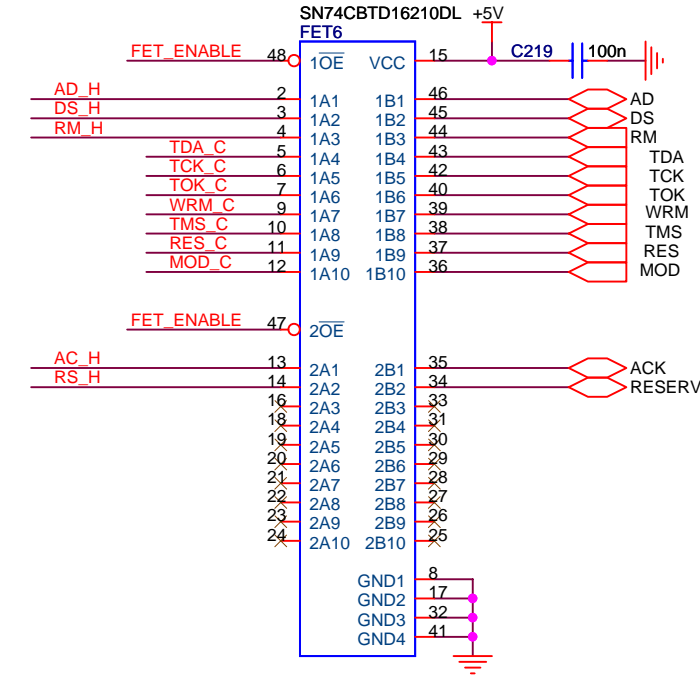

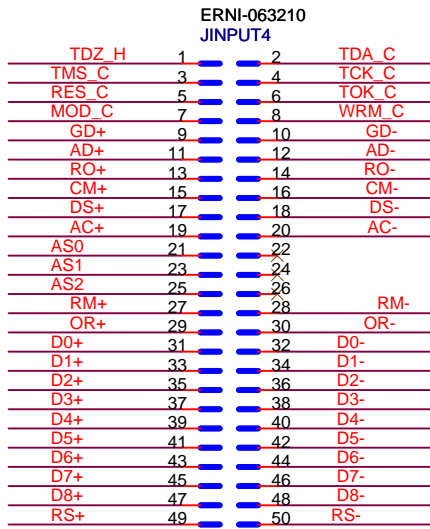

TDA - out
TMS - out
TCK - out
TDZ - in

RES - out
TOK - out
MOD - out
WRM - out
ADS - I/O

GDE - out only
CMS - out only
RDM - out only

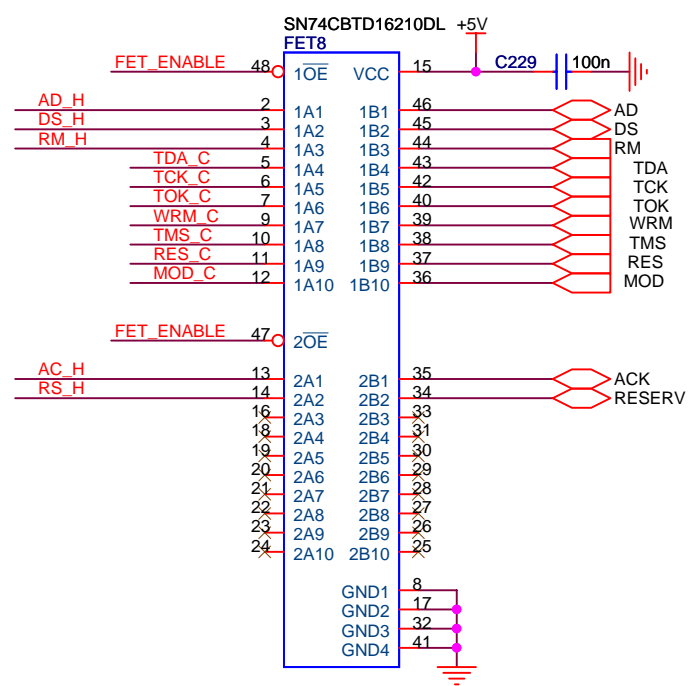
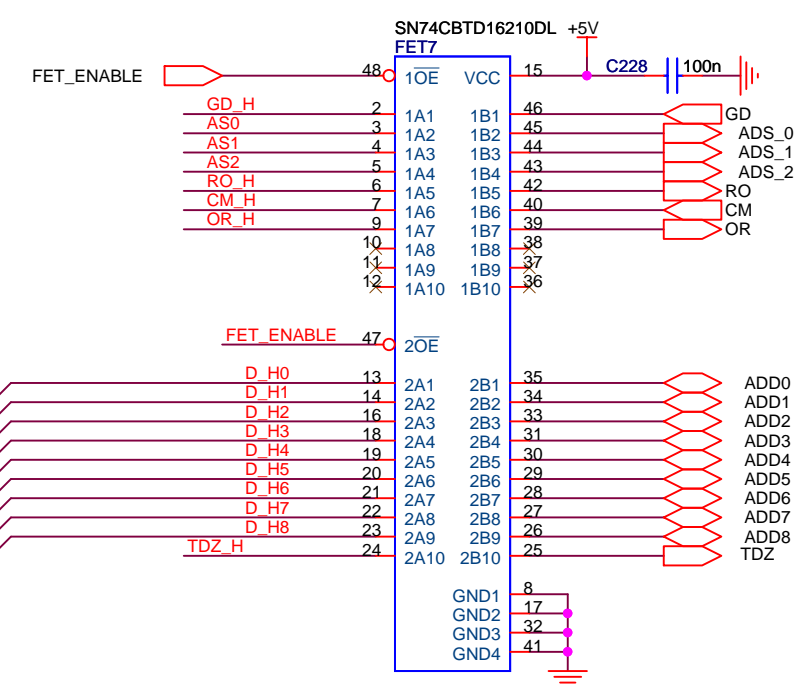
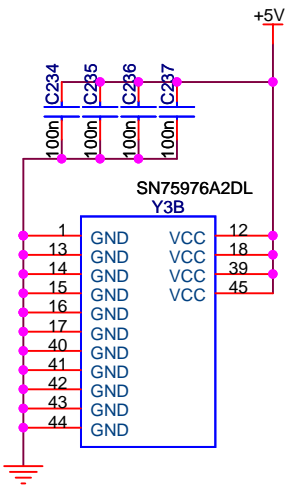
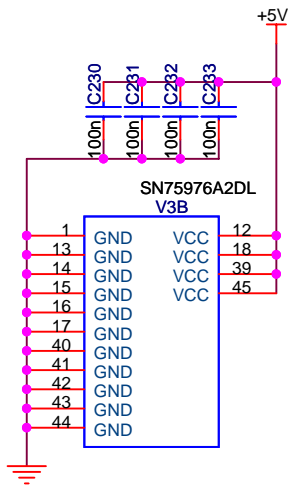
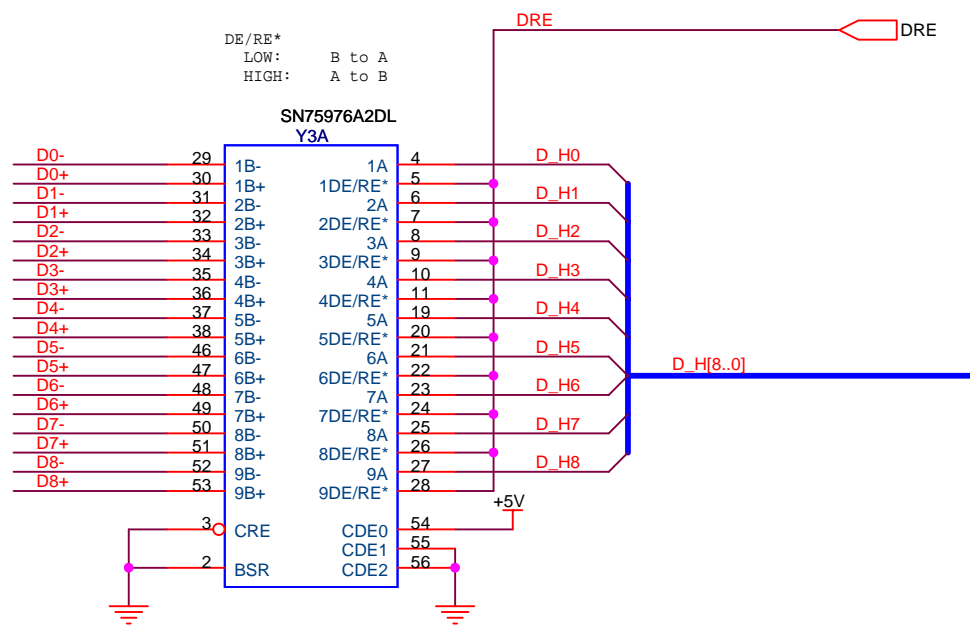
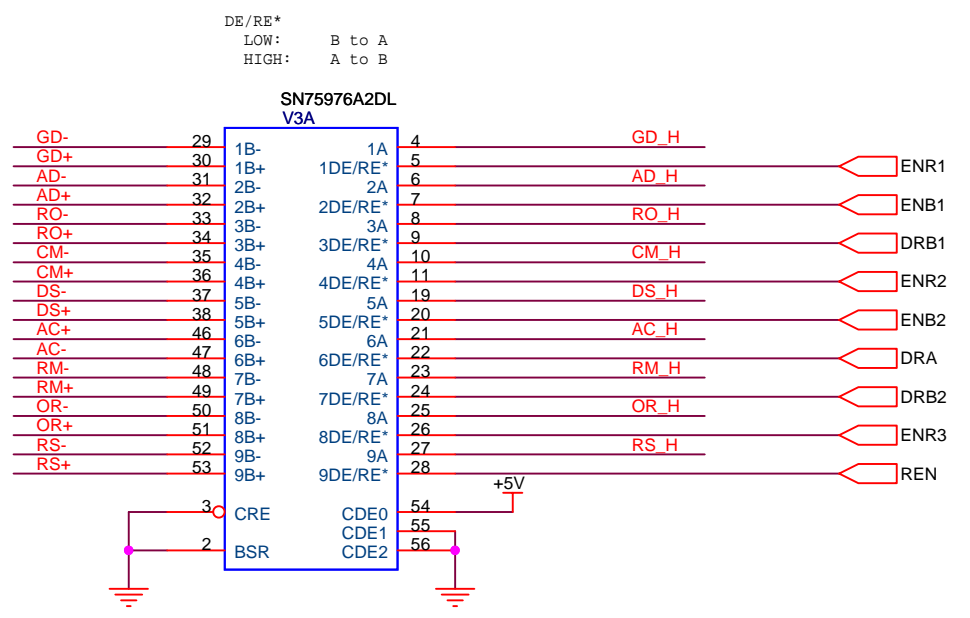

TDA - out
TMS - out
TCK - out
TDZ - in

RES - out
TOK - out
MOD - out
WRM - out
ADS - I/O

GDE - out only
CMS - out only
RDM - out only

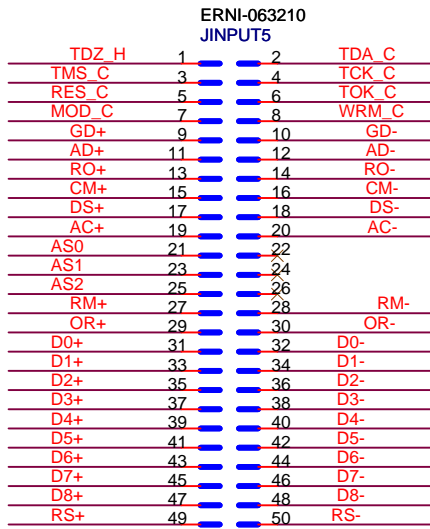

TDA - out
TMS - out
TCK - out
TDZ - in

RES - out
TOK - out
MOD - out
WRM - out
ADS - I/O

GDE - out only
CMS - out only
RDM - out only

DE/RE*
LOW: B to A
HIGH: A to B

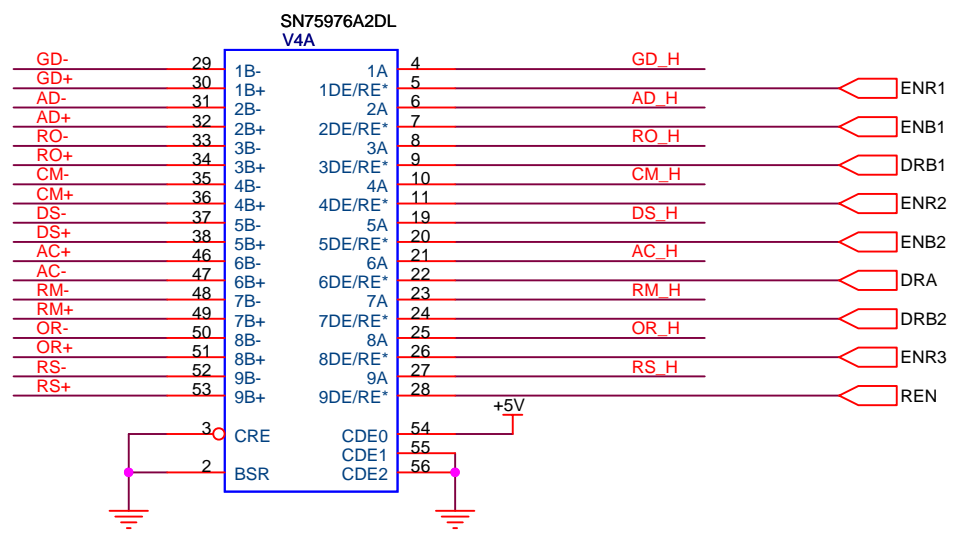

DE/RE*
LOW: B to A
HIGH: A to B

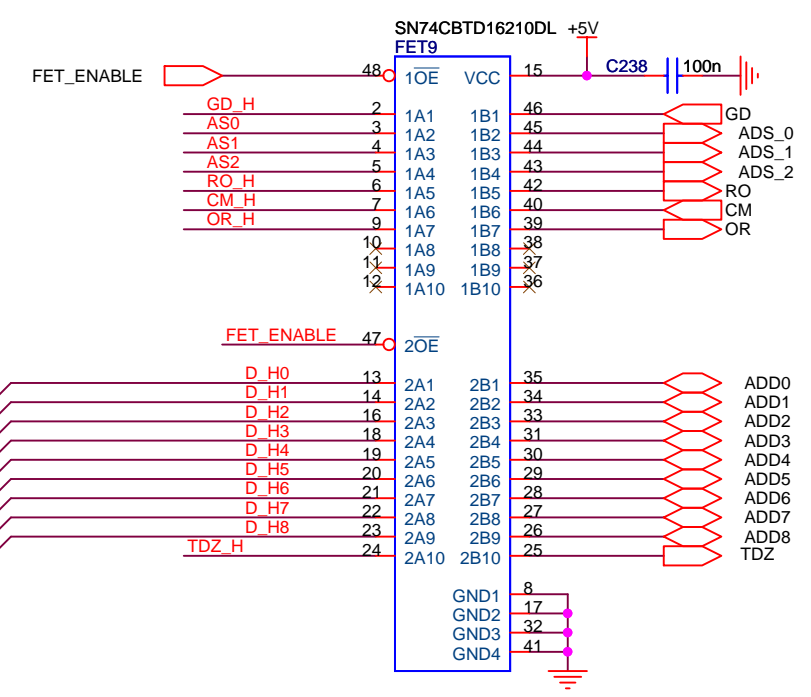
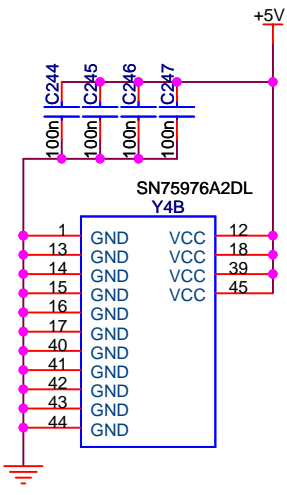
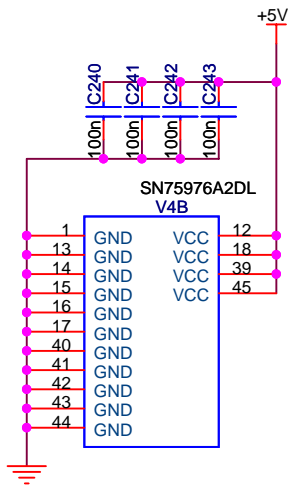
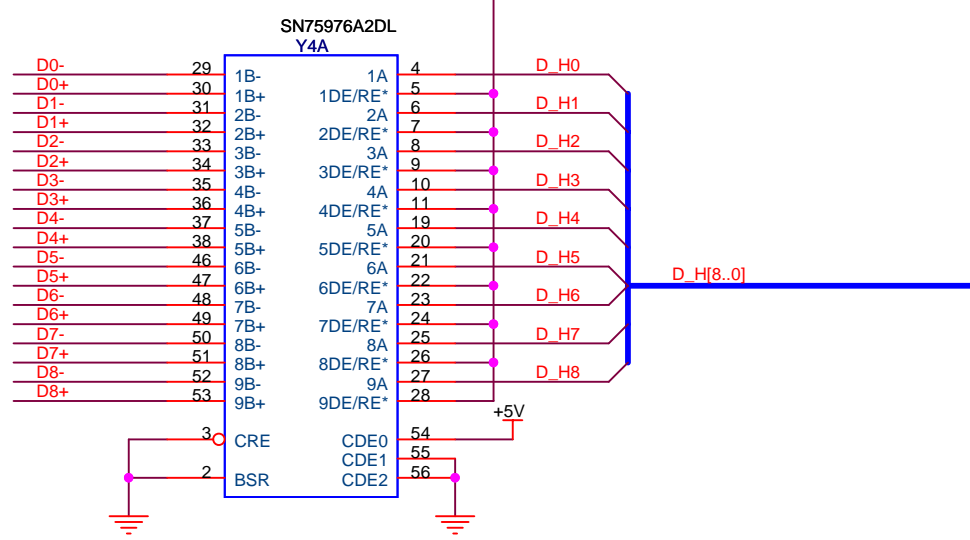

TDA - out
TMS - out
TCK - out
TDZ - in

RES - out
TOK - out
MOD - out
WRM - out
ADS - I/O

GDE - out only
CMS - out only
RDM - out only

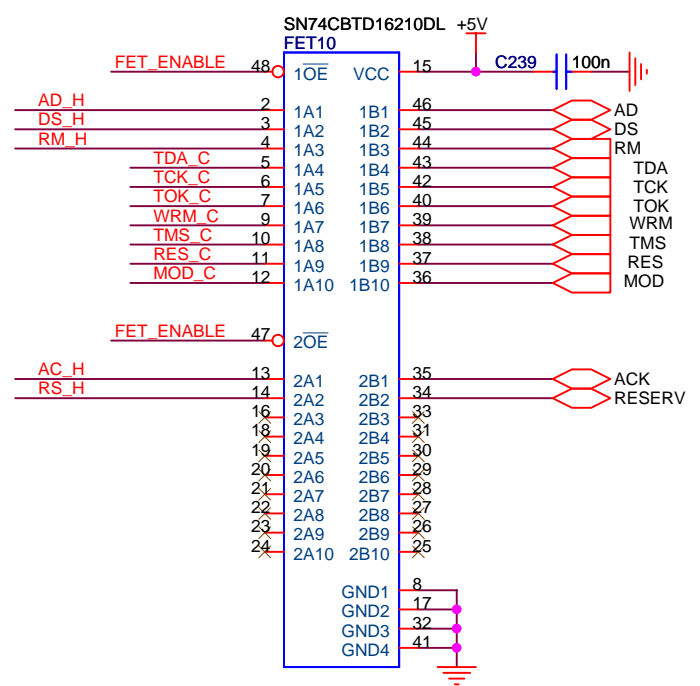

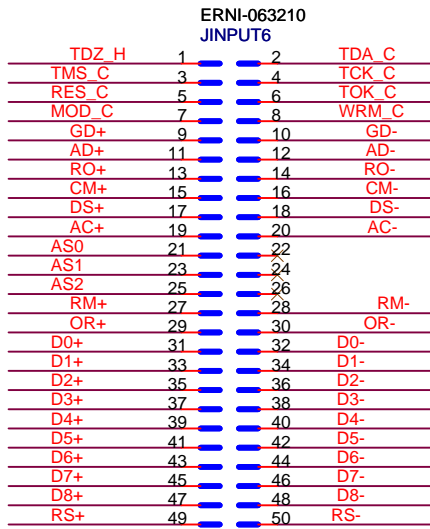

TDA - out
TMS - out
TCK - out
TDZ - in

RES - out
TOK - out
MOD - out
WRM - out
ADS - I/O

GDE - out only
CMS - out only
RDM - out only

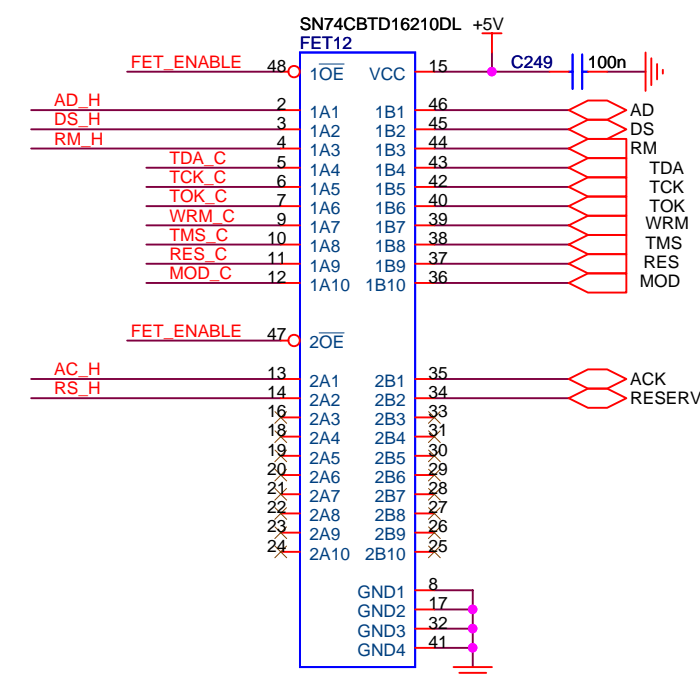
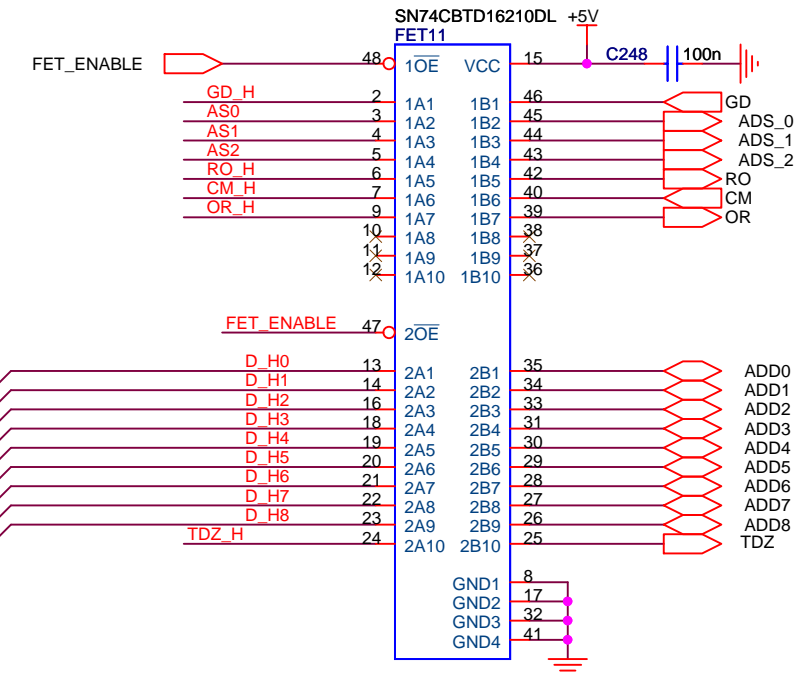
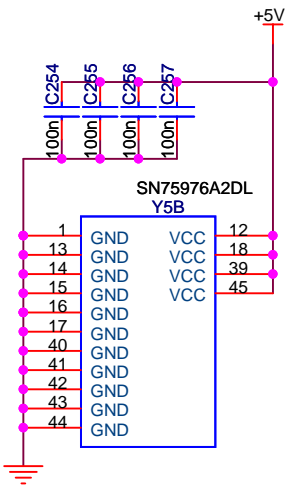
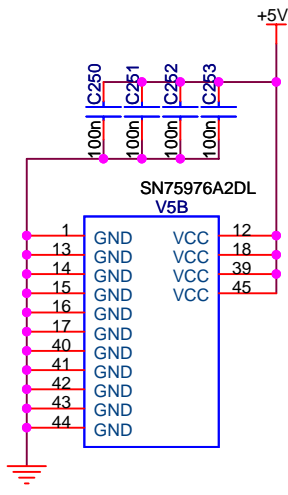
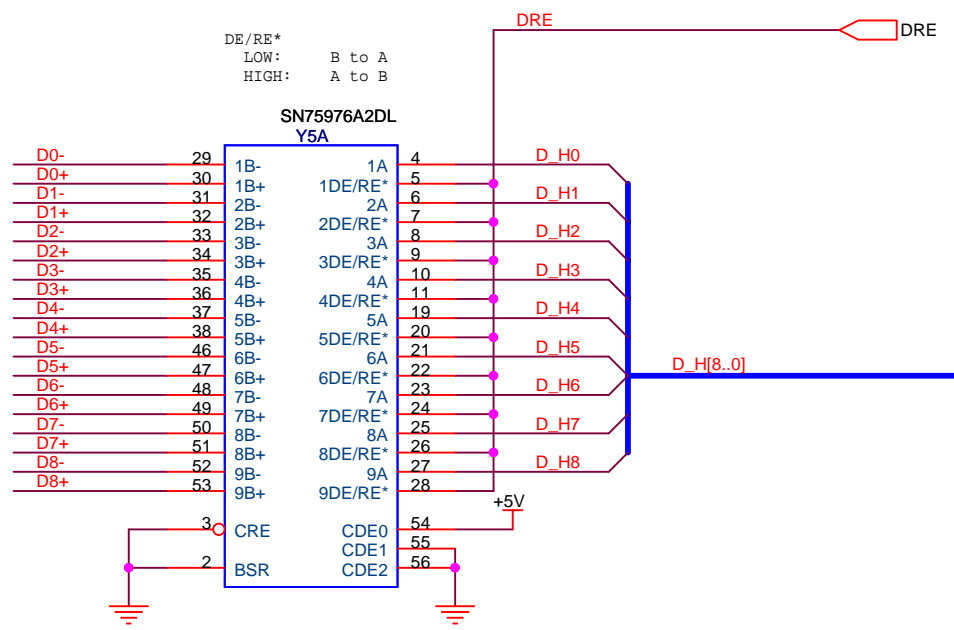
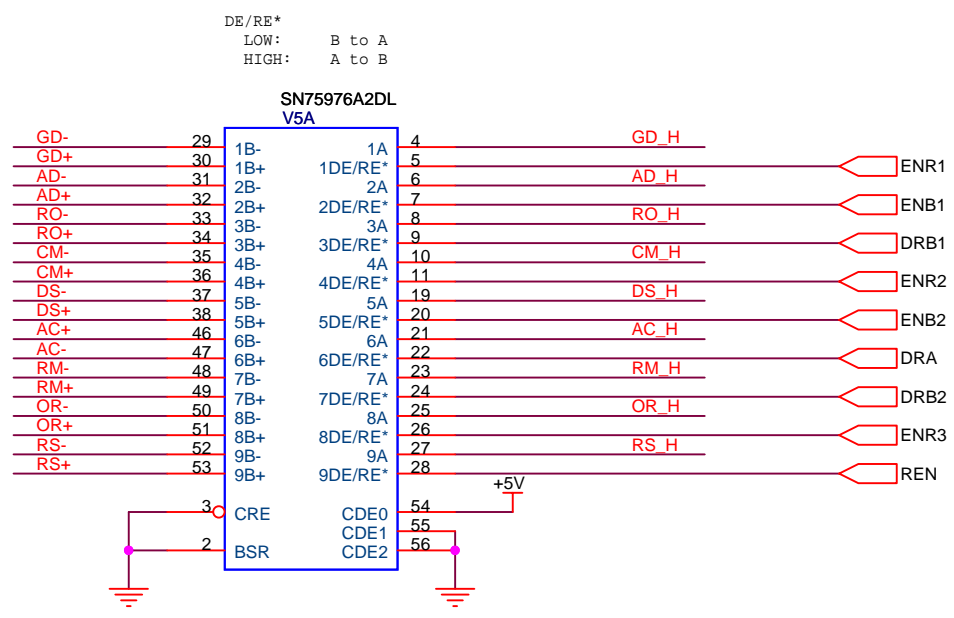

TDA - out
TMS - out
TCK - out
TDZ - in

RES - out
TOK - out
MOD - out
WRM - out
ADS - I/O

GDE - out only
CMS - out only
RDM - out only

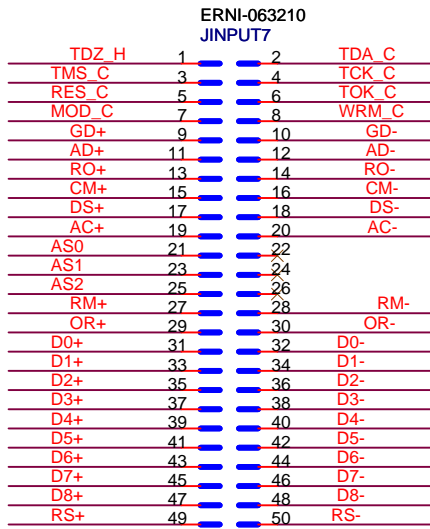

TDA - out
TMS - out
TCK - out
TDZ - in

RES - out
TOK - out
MOD - out
WRM - out
ADS - I/O

GDE - out only
CMS - out only
RDM - out only

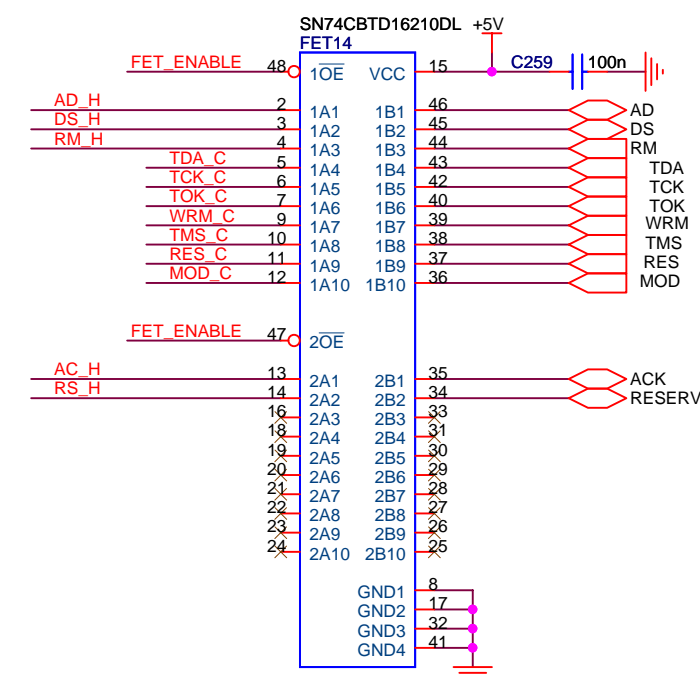
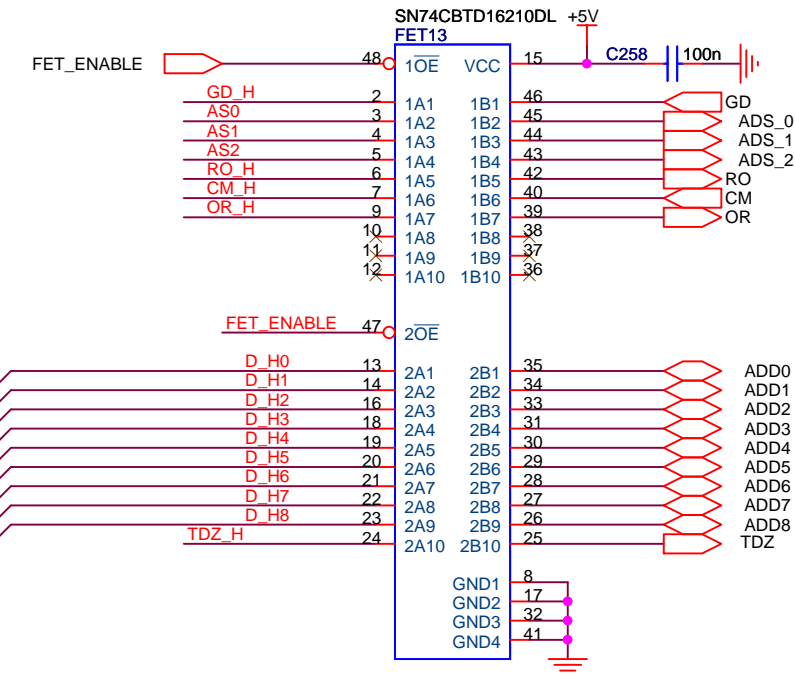
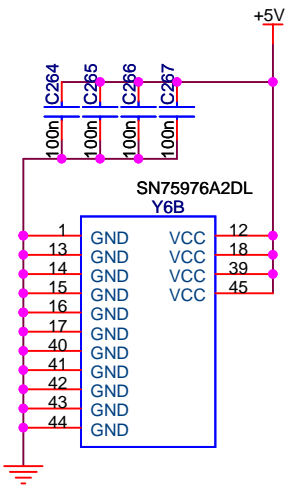
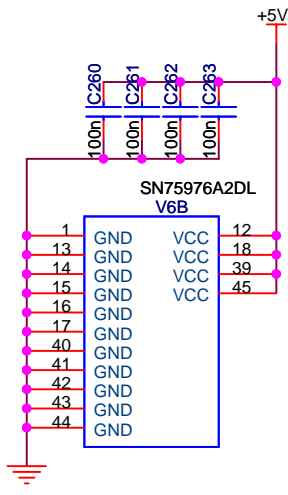
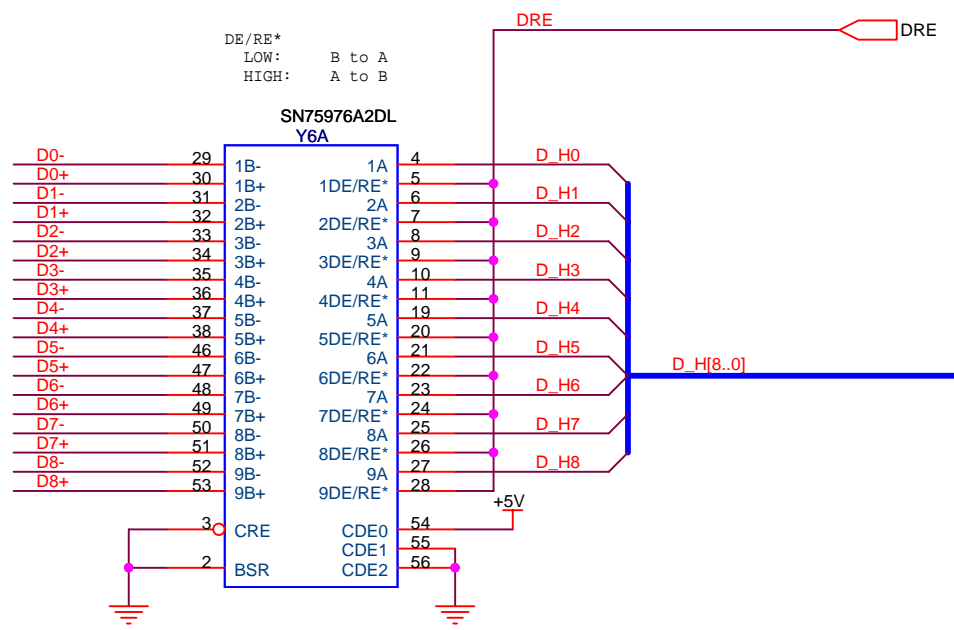
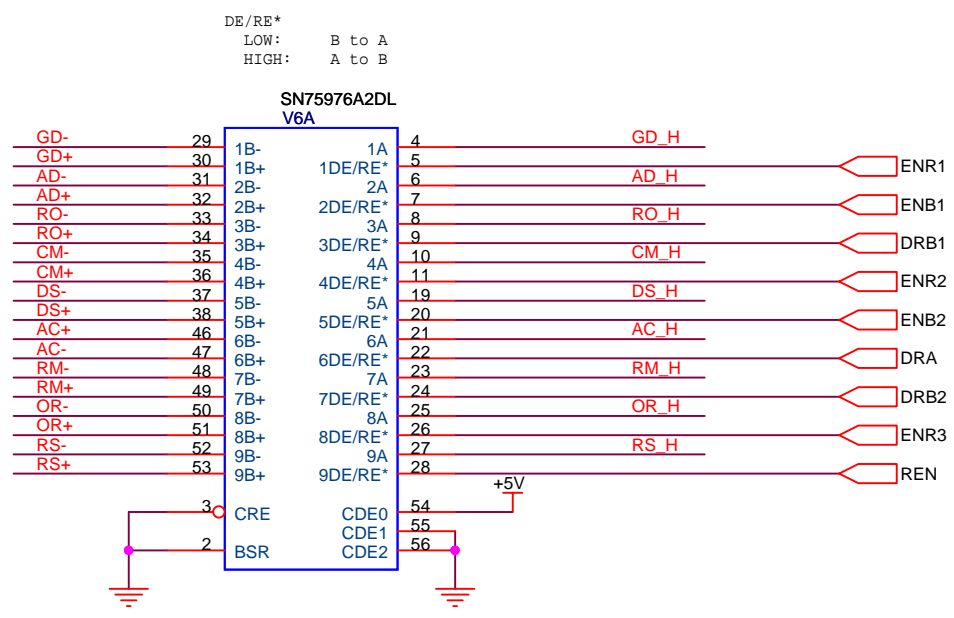

TDA - out
TMS - out
TCK - out
TDZ - in

RES - out
TOK - out
MOD - out
WRM - out
ADS - I/O

GDE - out only
CMS - out only
RDM - out only

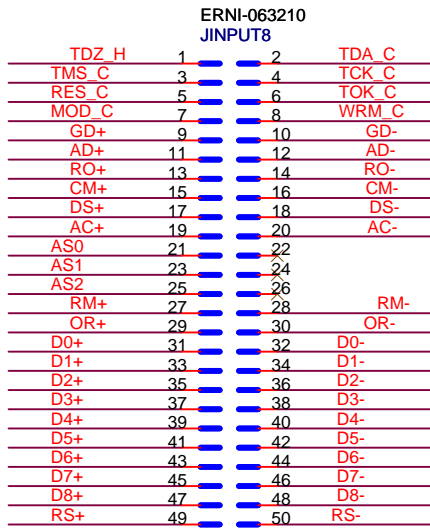

TDA - out
TMS - out
TCK - out
TDZ - in

RES - out
TOK - out
MOD - out
WRM - out
ADS - I/O

GDE - out only
CMS - out only
RDM - out only

DE/RE*
LOW: B to A
HIGH: A to B

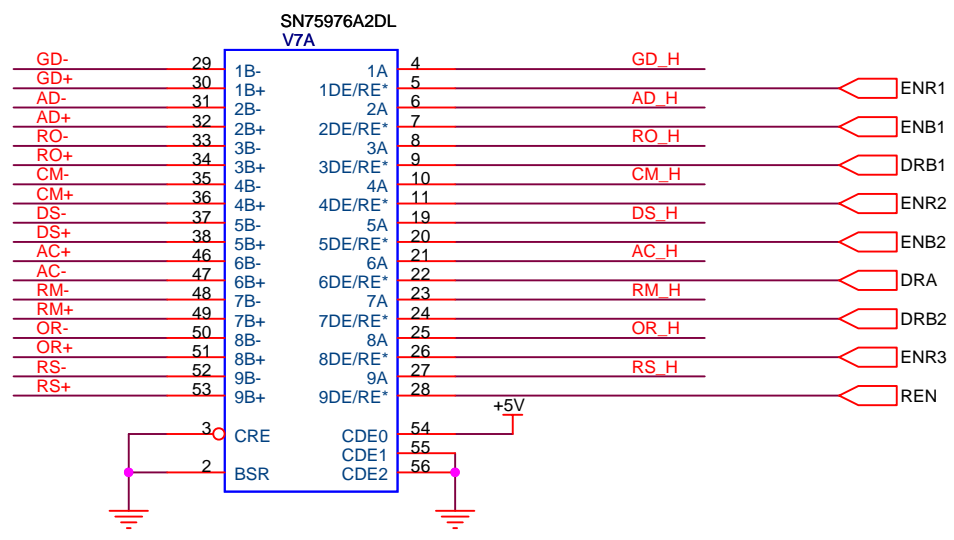

DE/RE*
LOW: B to A
HIGH: A to B

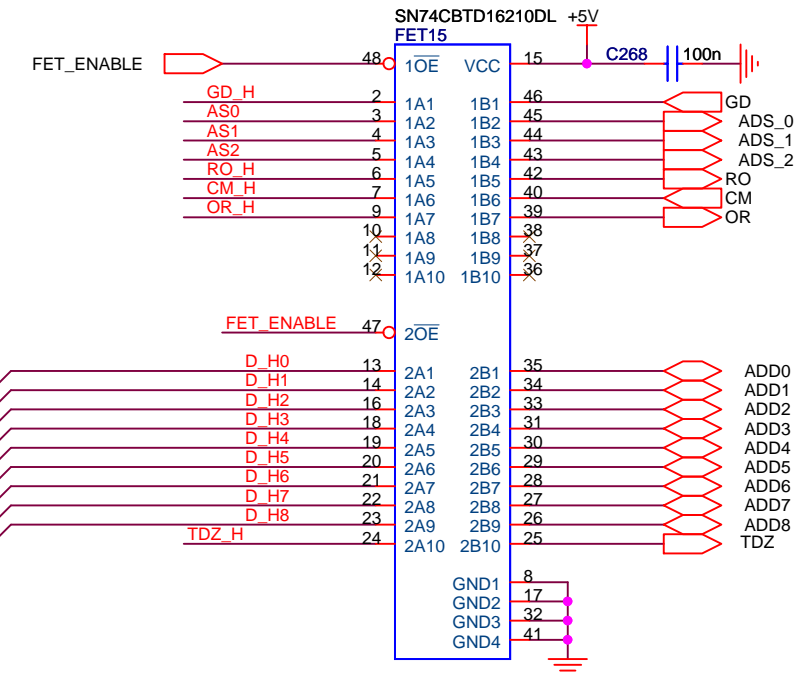
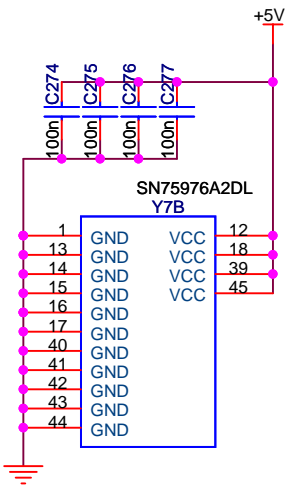
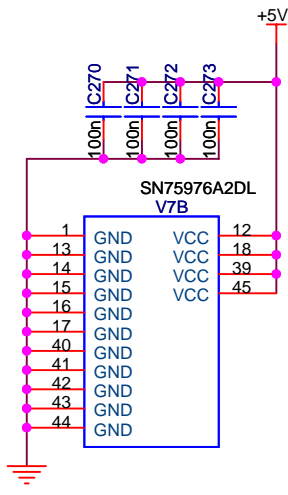
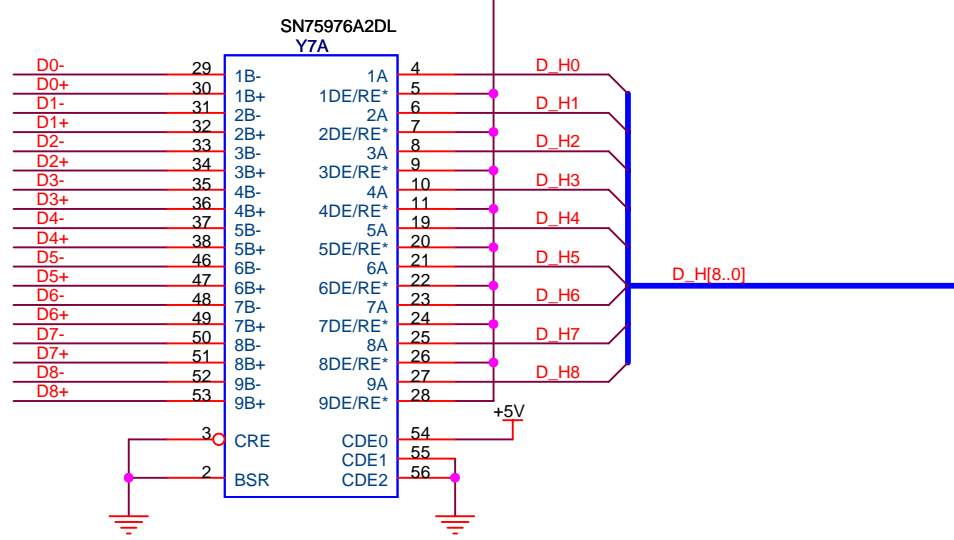

TDA - out
TMS - out
TCK - out
TDZ - in

RES - out
TOK - out
MOD - out
WRM - out
ADS - I/O

GDE - out only
CMS - out only
RDM - out only

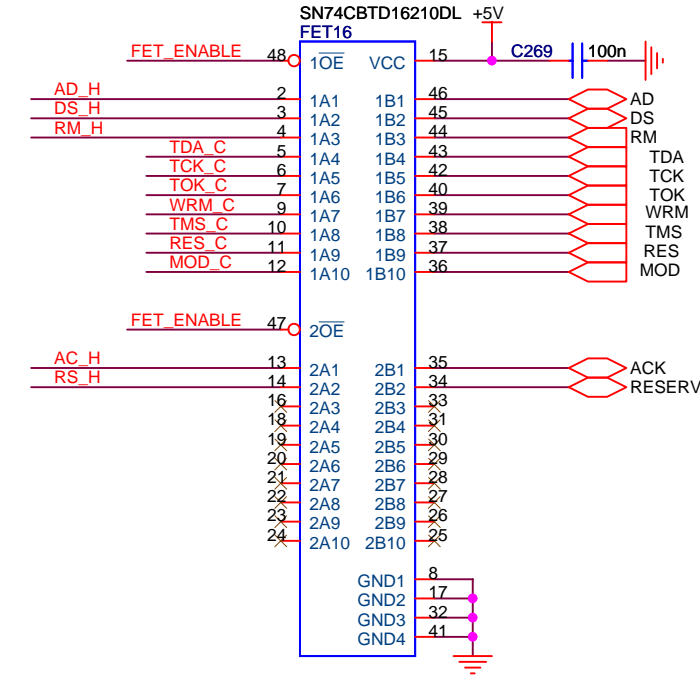

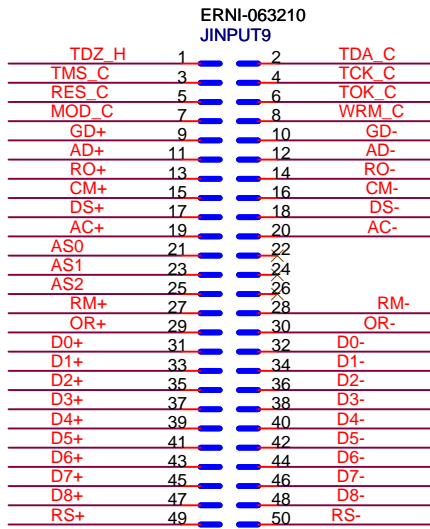

TDA - out
TMS - out
TCK - out
TDZ - in

RES - out
TOK - out
MOD - out
WRM - out
ADS - I/O

GDE - out only
CMS - out only
RDM - out only

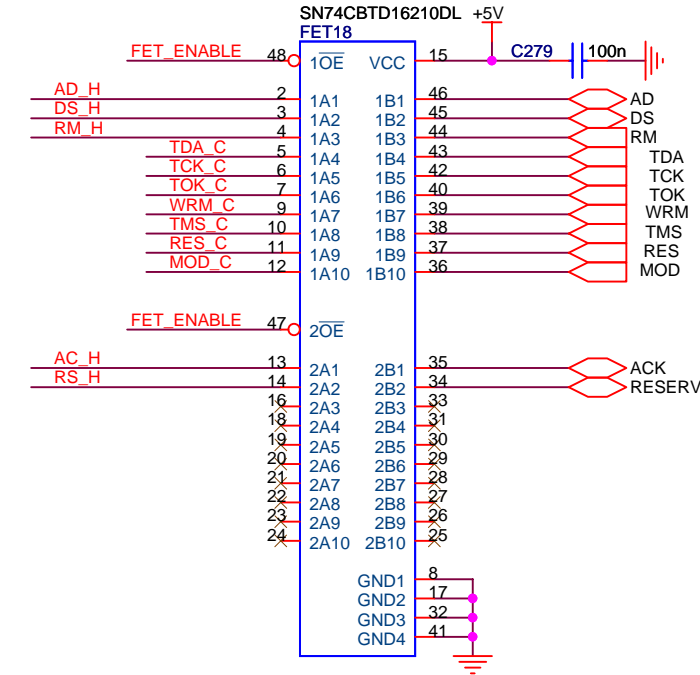
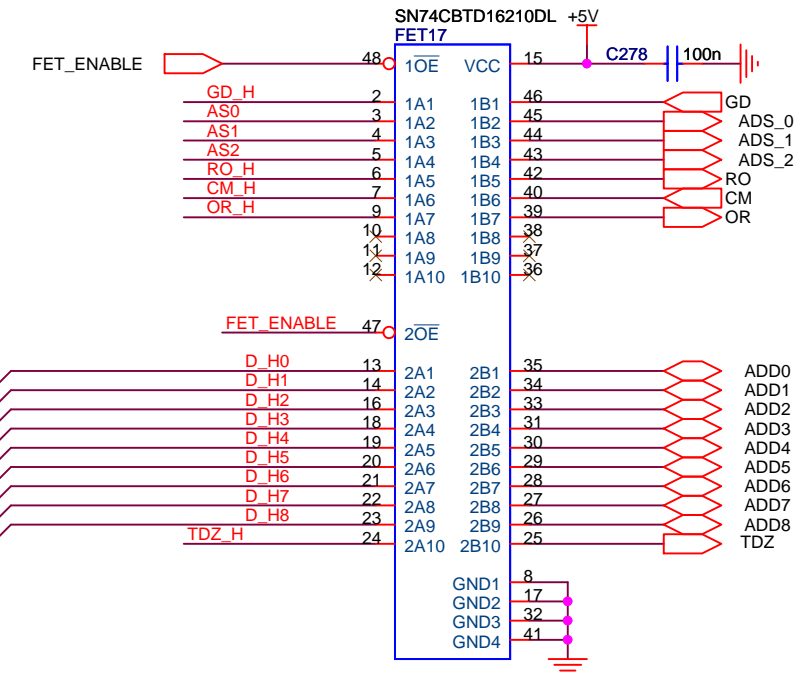
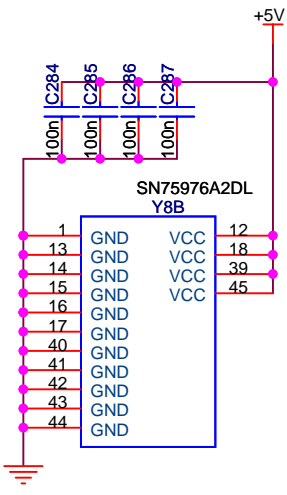
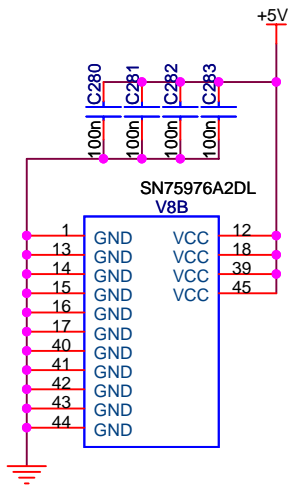
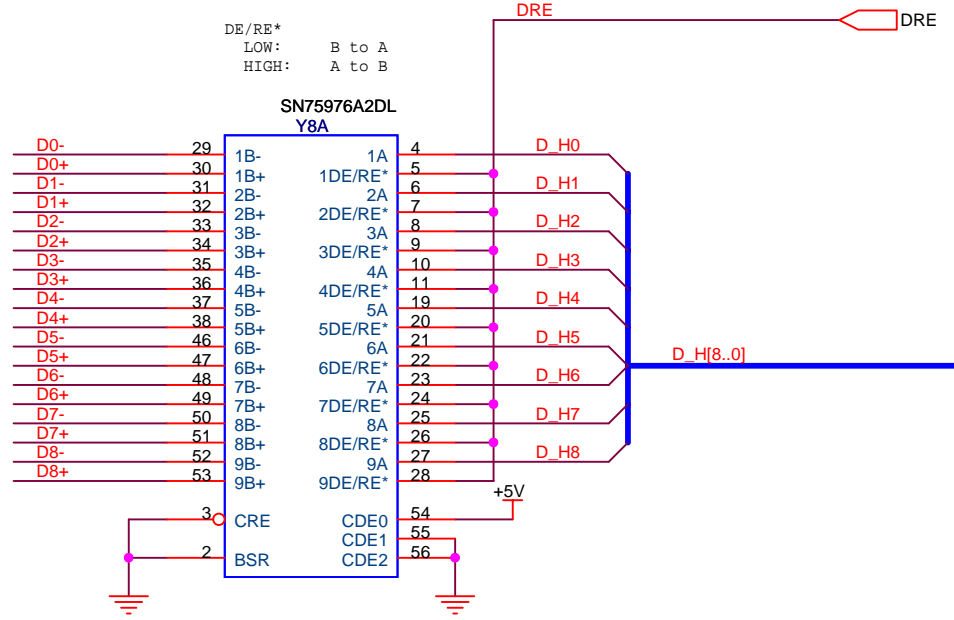
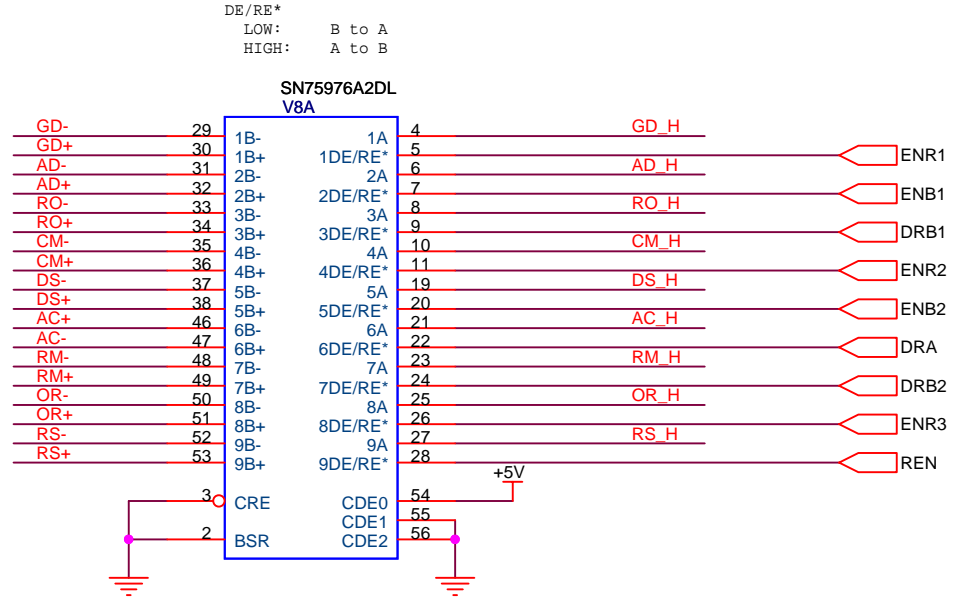

TDA - out
TMS - out
TCK - out
TDZ - in

RES - out
TOK - out
MOD - out
WRM - out
ADS - I/O

GDE - out only
CMS - out only
RDM - out only

ERNI-063210
JINPUT10

TDZ_H	1	2	TDA_C
TMS_C	3	4	TCK_C
RES_C	5	6	TOK_C
MOD_C	7	8	WRM_C
GD+	9	10	GD-
AD+	11	12	AD-
RO+	13	14	RO-
CM+	15	16	CM-
DS+	17	18	DS-
AC+	19	20	AC-
AS0	21	22	
AS1	23	24	
AS2	25	26	
RM+	27	28	RM-
OR+	29	30	OR-
D0+	31	32	D0-
D1+	33	34	D1-
D2+	35	36	D2-
D3+	37	38	D3-
D4+	39	40	D4-
D5+	41	42	D5-
D6+	43	44	D6-
D7+	45	46	D7-
D8+	47	48	D8-
RS+	49	50	RS-

TDA - out
TMS - out
TCK - out
TDZ - in

RES - out
TOK - out
MOD - out
WRM - out
ADS - I/O

GDE - out only
CMS - out only
RDM - out only

DE/RE*
LOW: B to A
HIGH: A to B

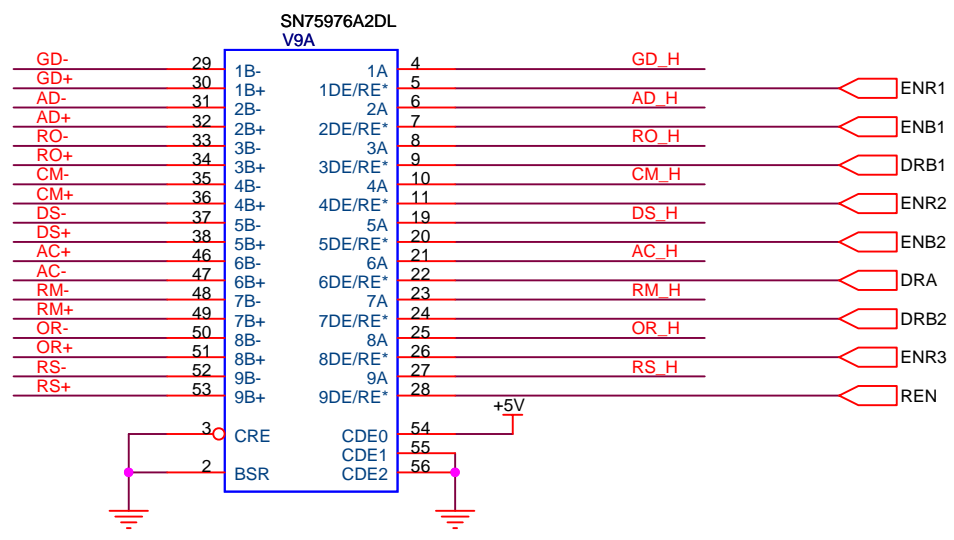

DE/RE*
LOW: B to A
HIGH: A to B

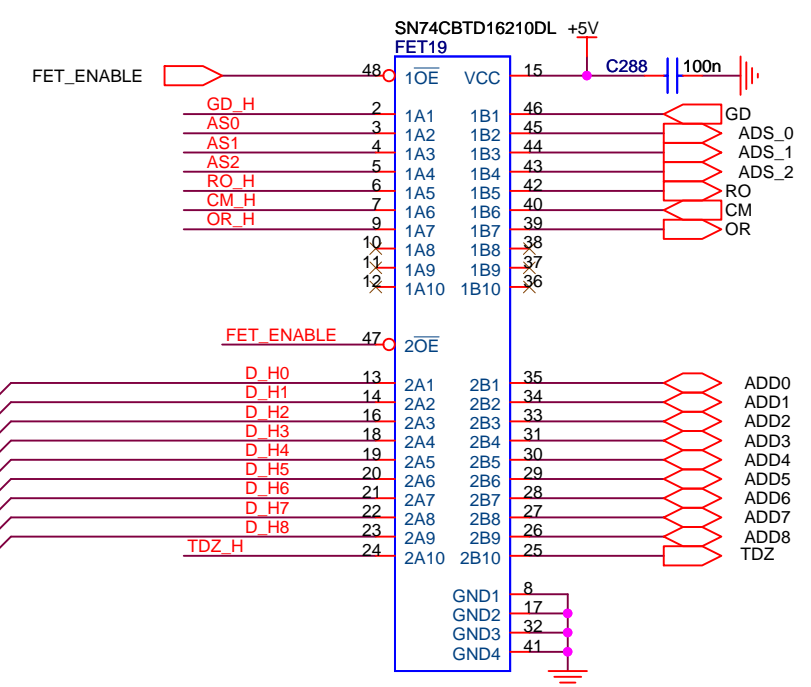
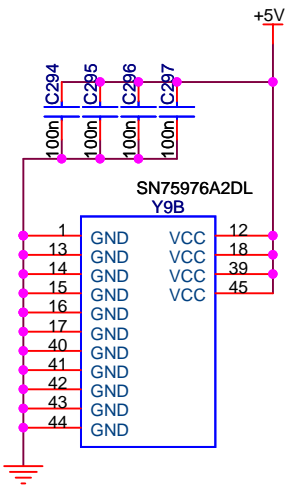
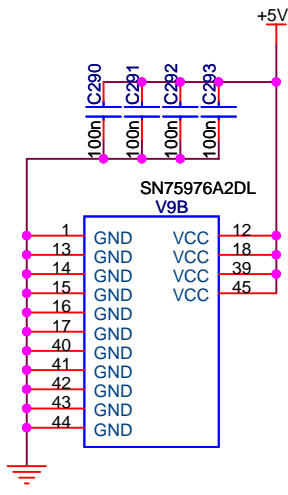
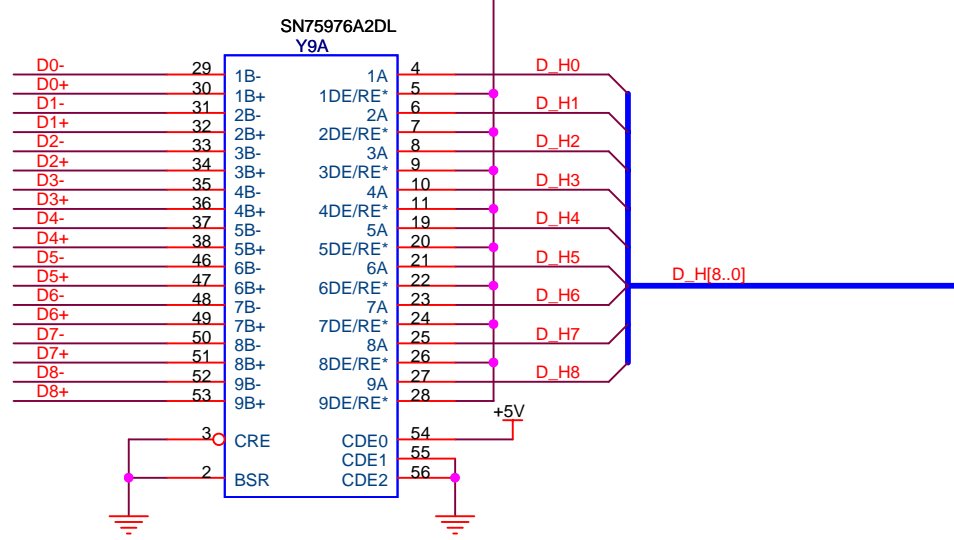

TDA - out
TMS - out
TCK - out
TDZ - in

RES - out
TOK - out
MOD - out
WRM - out
ADS - I/O

GDE - out only
CMS - out only
RDM - out only

