

TRB_CONNECTOR1A

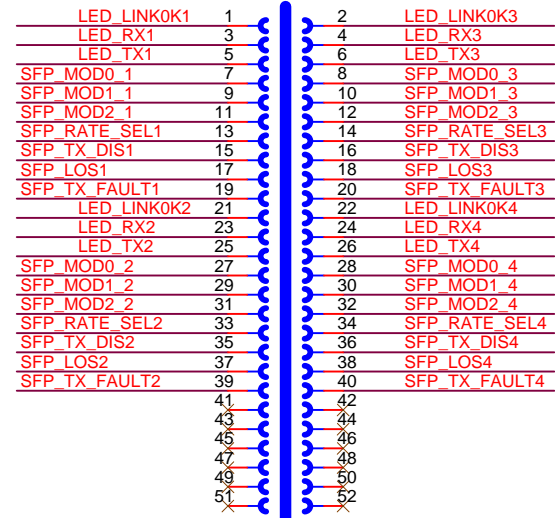

TRB_CONNECTOR1B

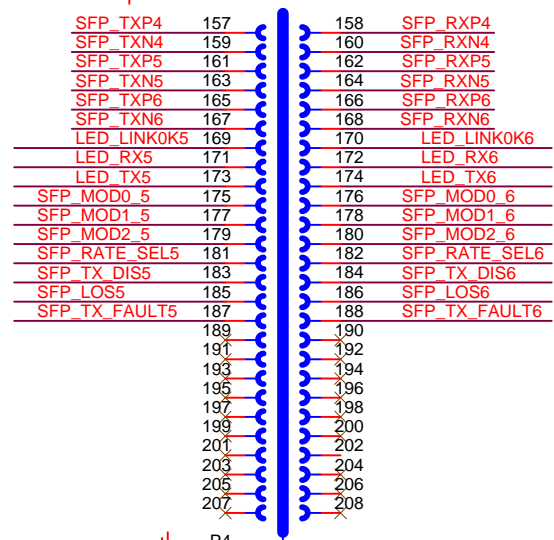
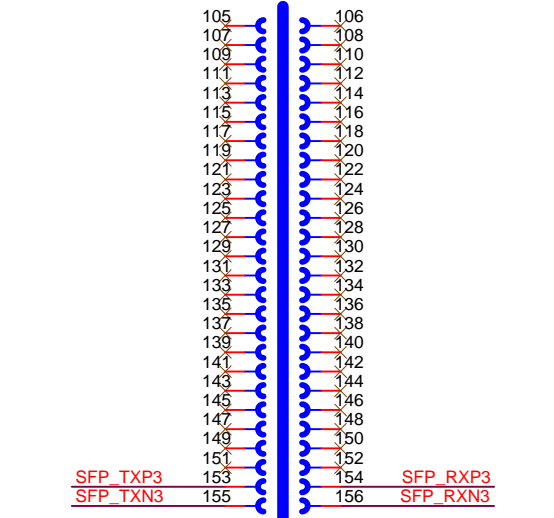

QFS-104-06.25-SL-D-A

QFS-104-06.25-SL-D-A

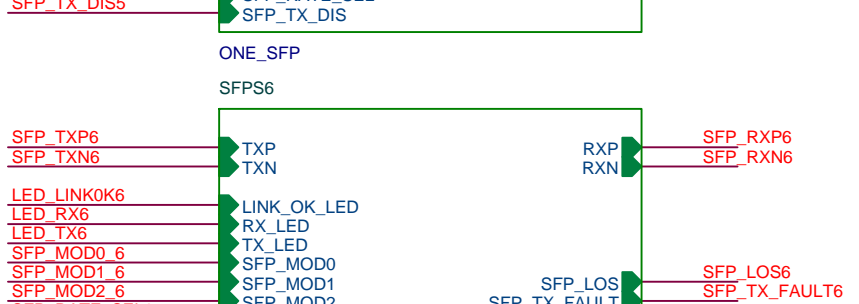
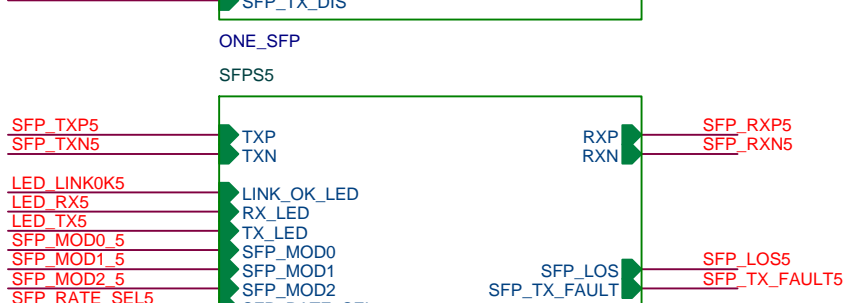
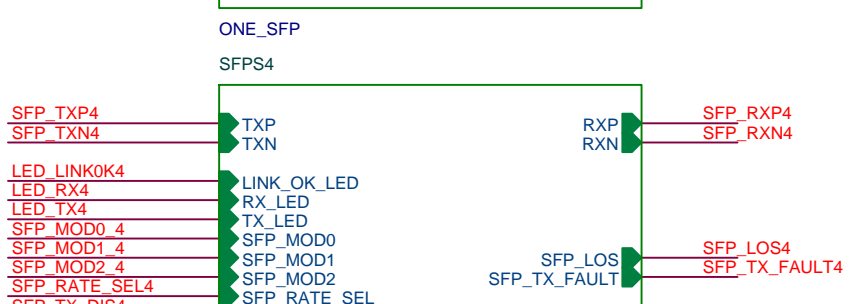
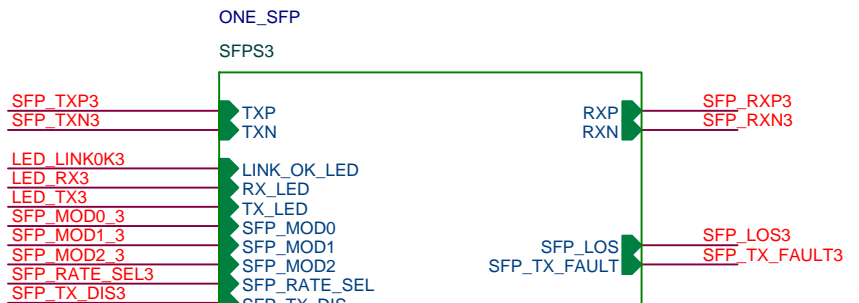
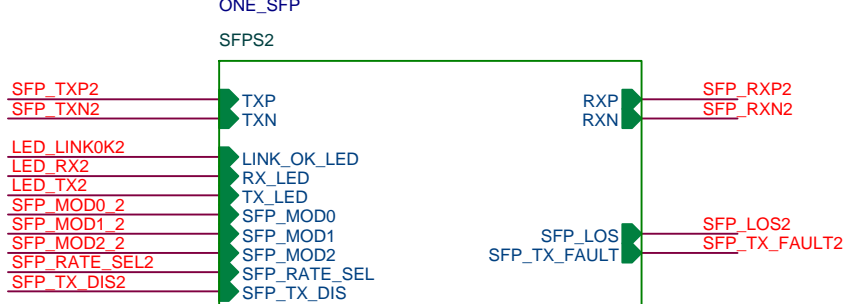
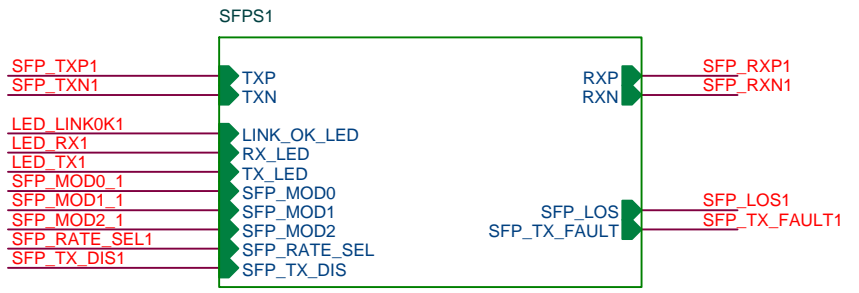
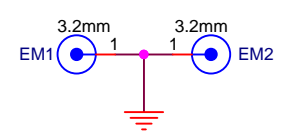

ONE_SFP

gsi Gesellschaft für Schwerionenforschung mbH
 Planckstrasse 1
 D-64291 Darmstadt
 GERMANY
 www.gsi.de

01_TRB_CONNECTOR

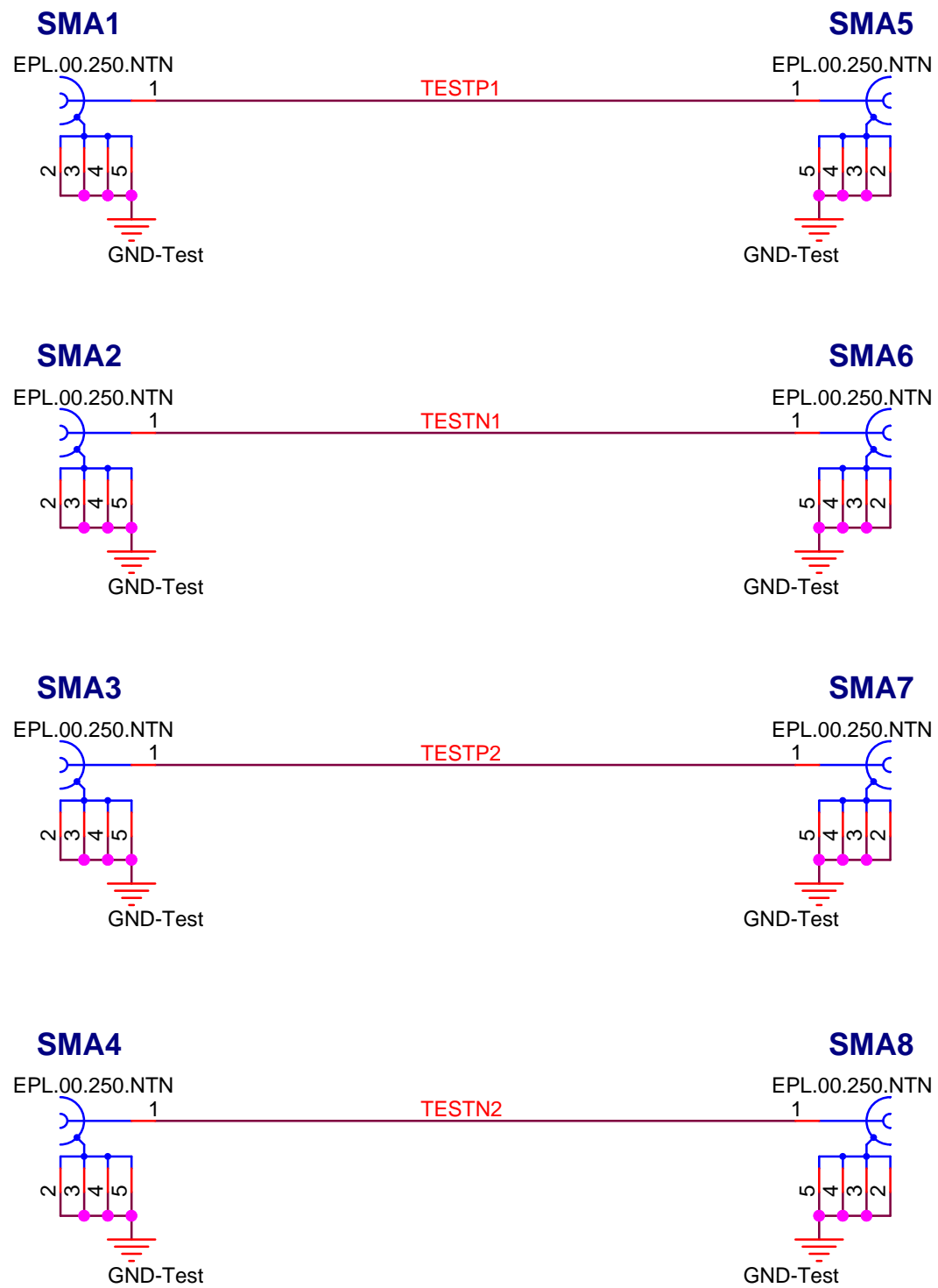

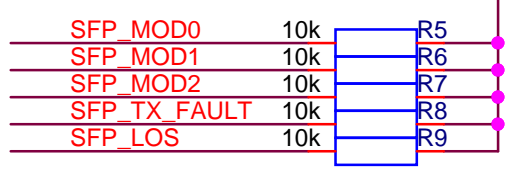
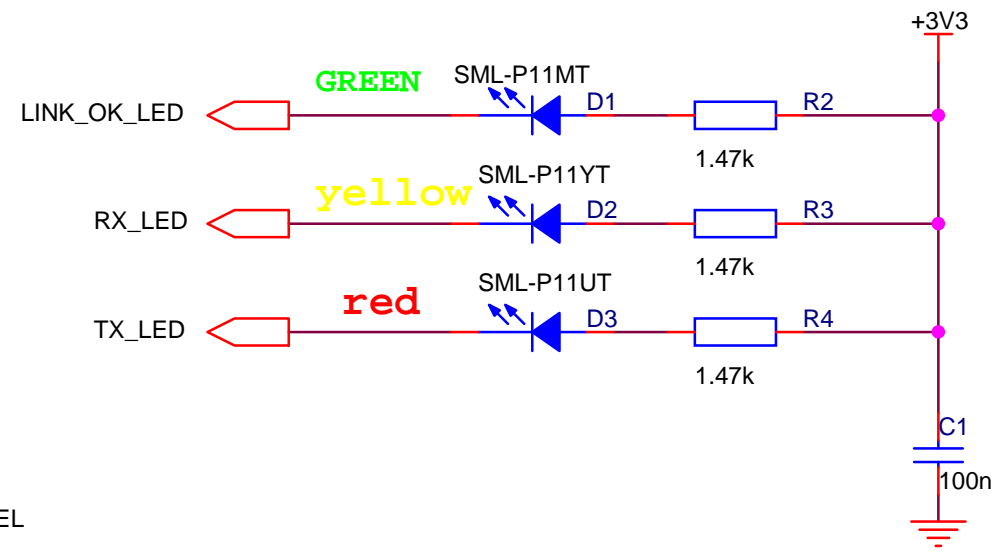
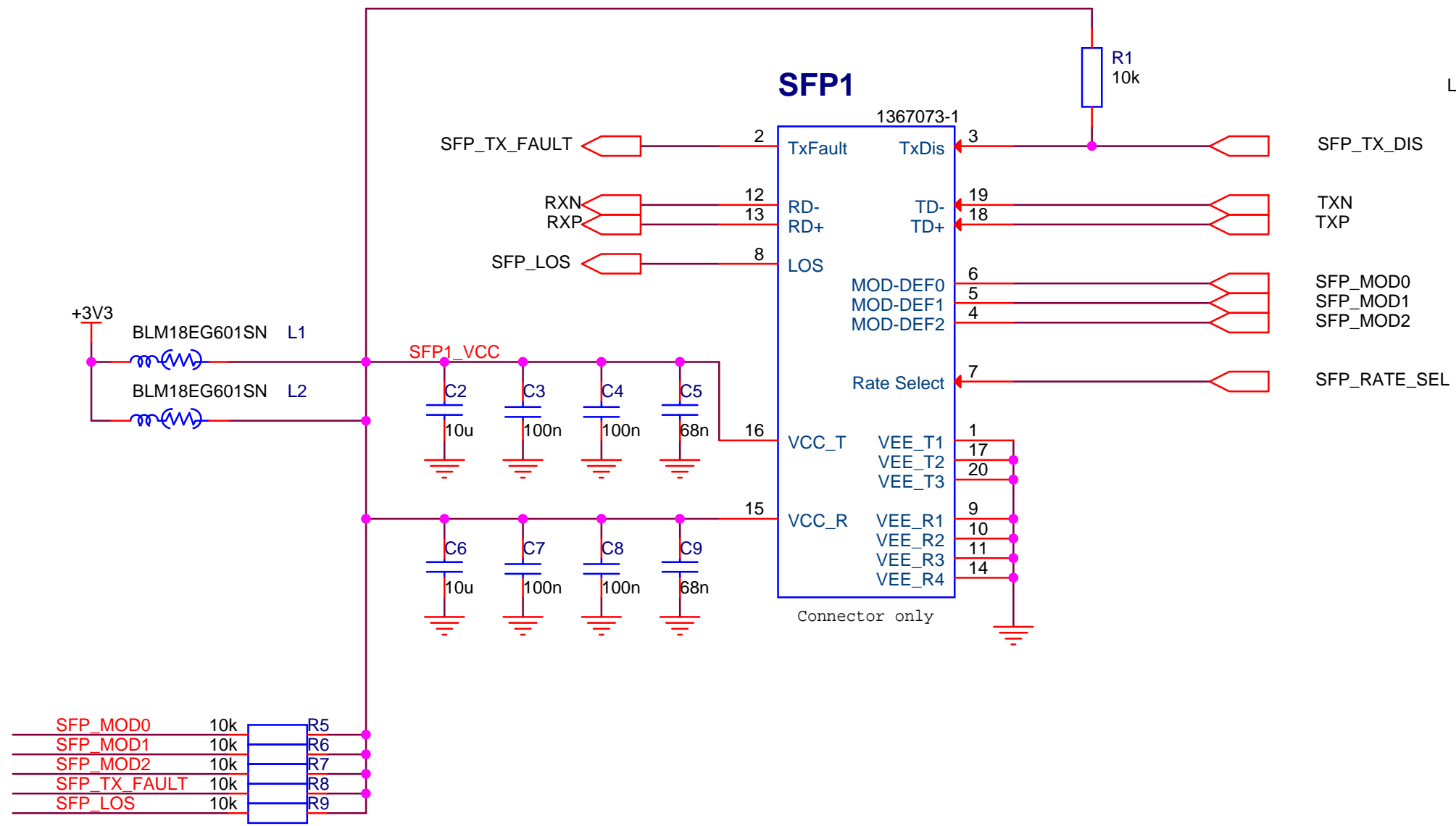

MODDEF0 is grounded by module when inserted

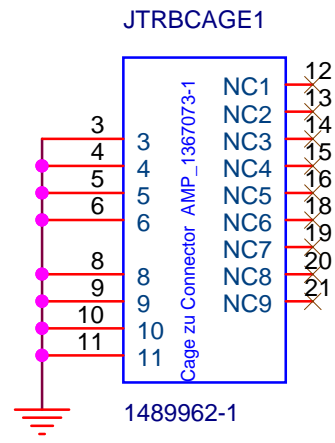

GbE

GSI Gesellschaft für Schwerionenforschung mbH
 Planckstrasse 1
 D-64291 Darmstadt
 GERMANY
 www.gsi.de

SFP

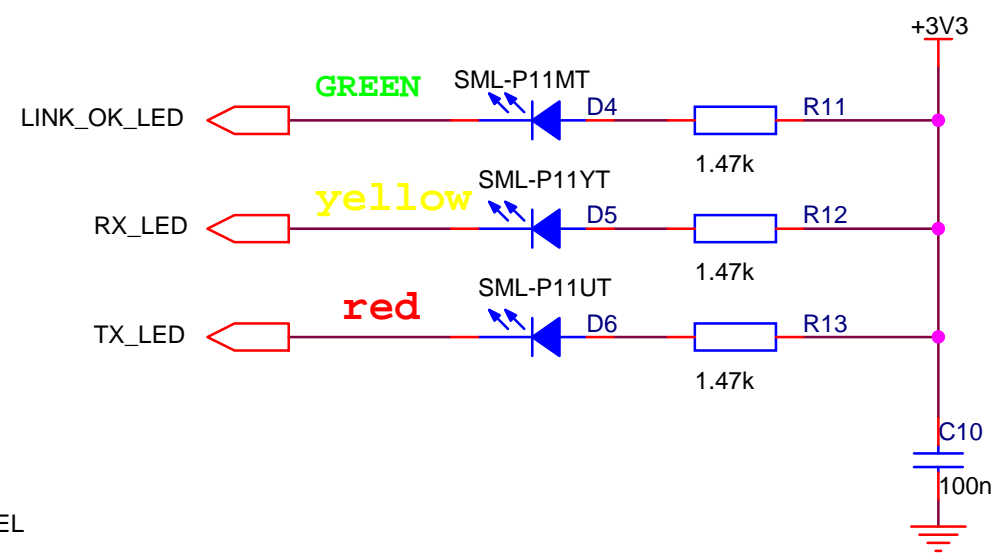
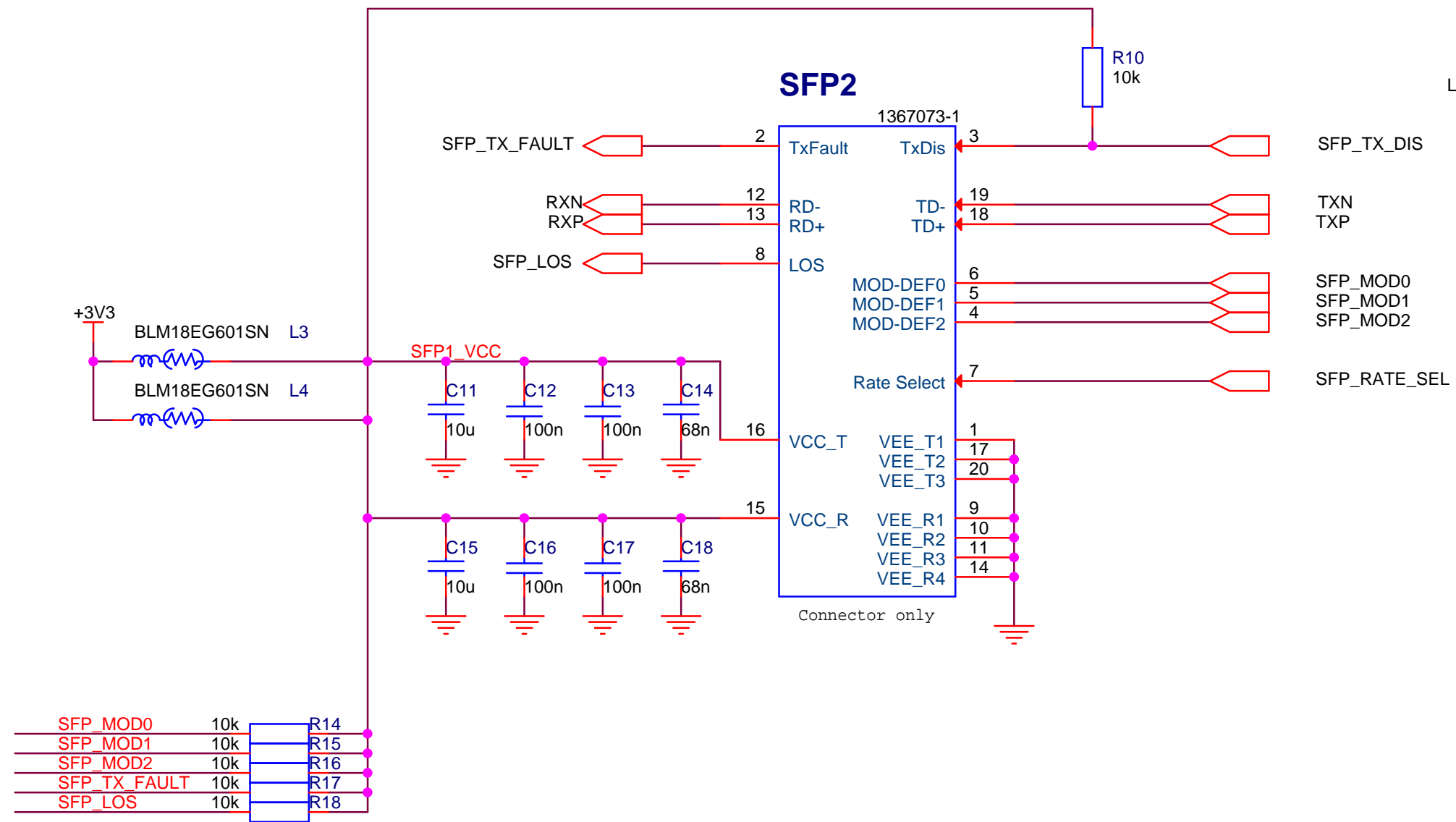

SFP_MOD0	10k	R14
SFP_MOD1	10k	R15
SFP_MOD2	10k	R16
SFP_TX_FAULT	10k	R17
SFP_LOS	10k	R18

MODDEF0 is grounded by module when inserted

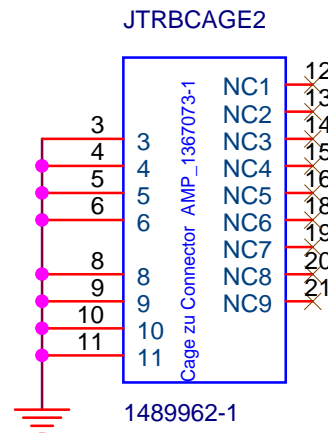

GbE

GSi Gesellschaft für Schwerionenforschung mbH
 Planckstrasse 1
 D-64291 Darmstadt
 GERMANY
 www.gsi.de

SFP

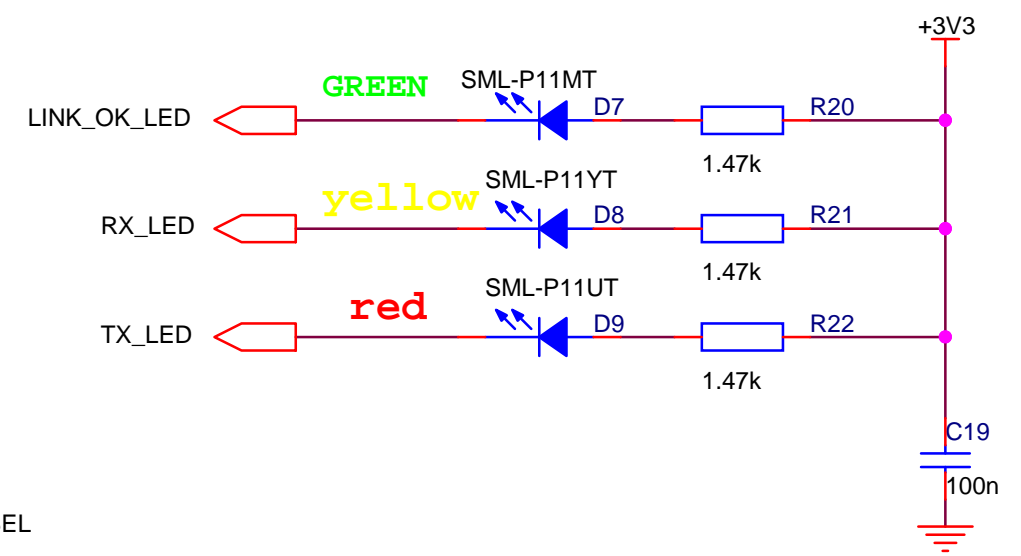
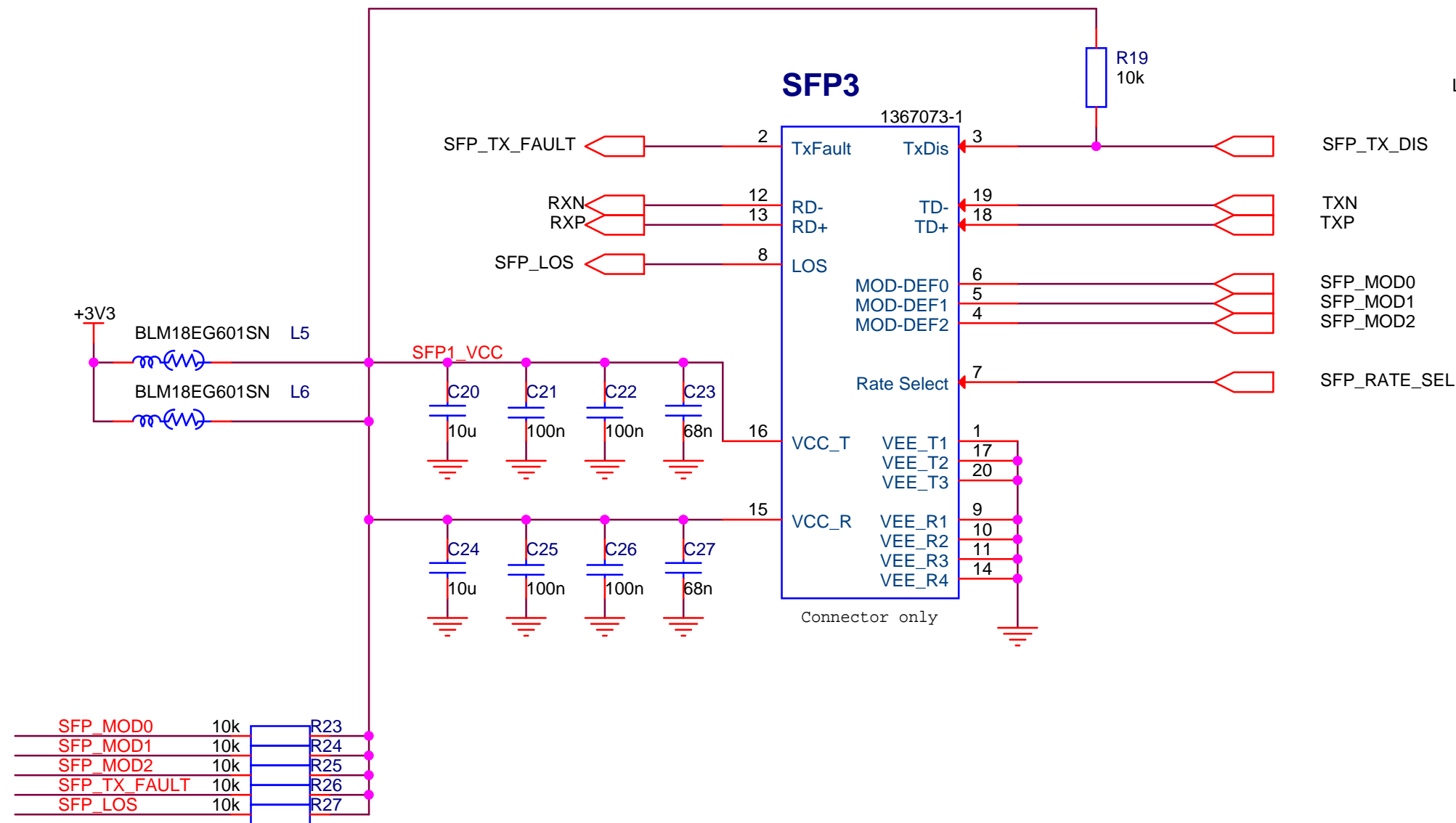

SFP_MOD0	10k	R23
SFP_MOD1	10k	R24
SFP_MOD2	10k	R25
SFP_TX_FAULT	10k	R26
SFP_LOS	10k	R27

MODDEF0 is grounded by module when inserted

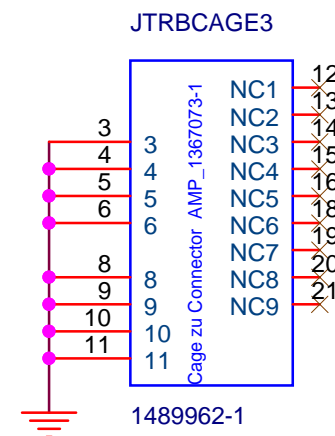

GbE

GSi Gesellschaft für Schwerionenforschung mbH
 Planckstrasse 1
 D-64291 Darmstadt
 GERMANY
 www.gsi.de

SFP

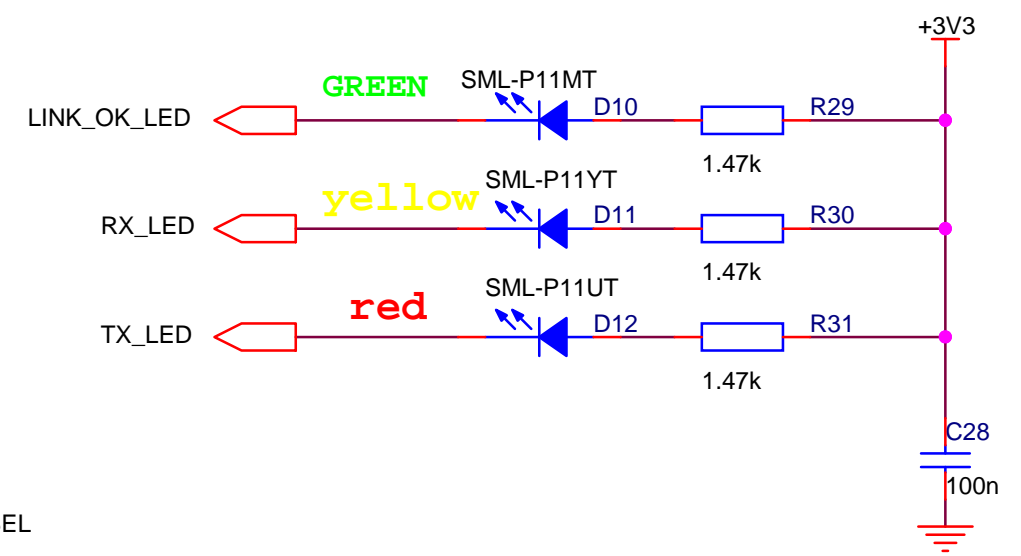
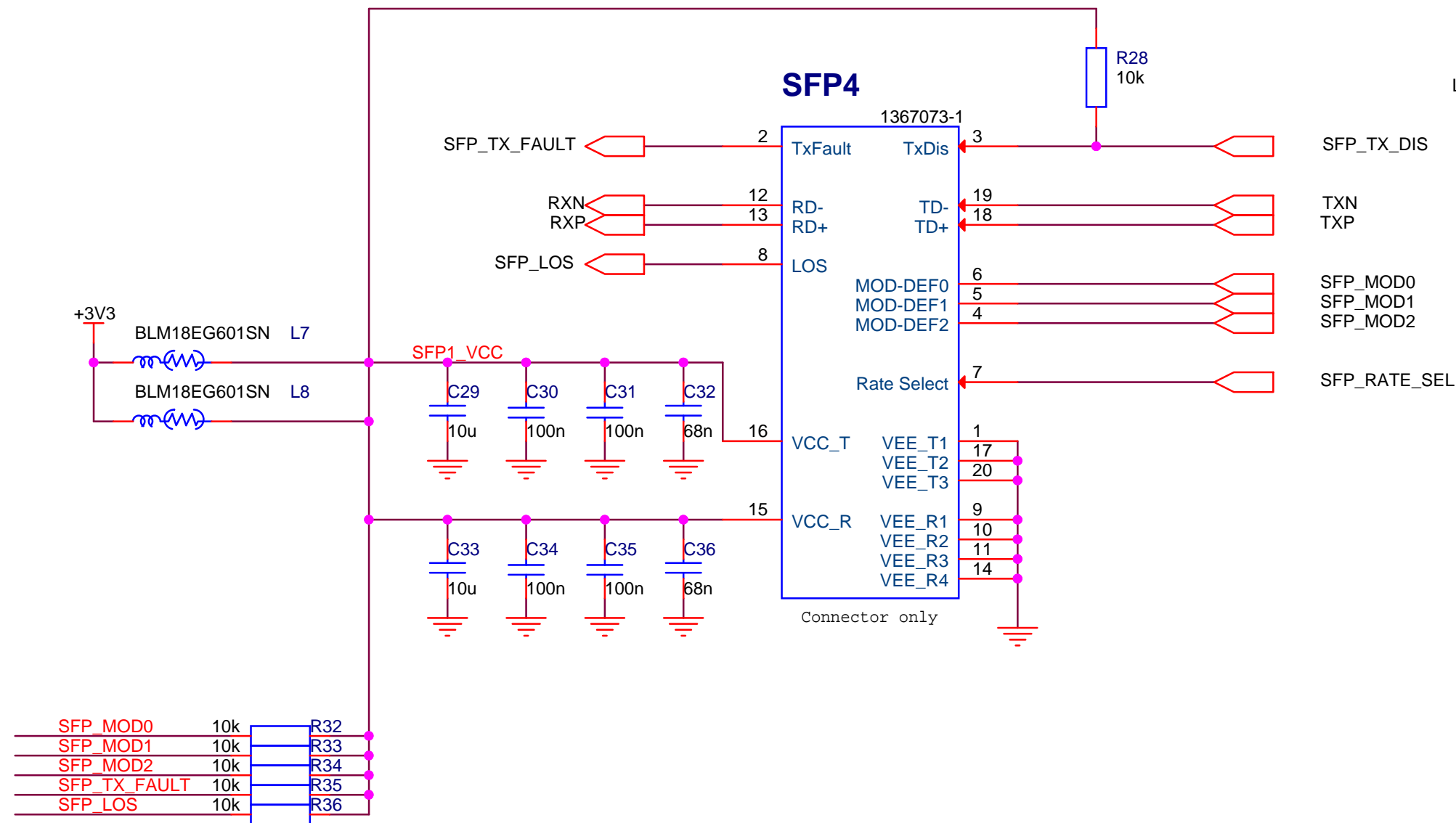

MODDEF0 is grounded by module when inserted

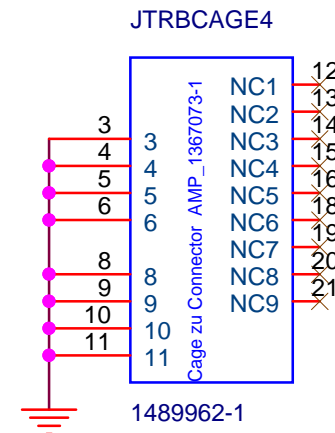

GbE

GSi Gesellschaft für Schwerionenforschung mbH
 Planckstrasse 1
 D-64291 Darmstadt
 GERMANY
 www.gsi.de

SFP

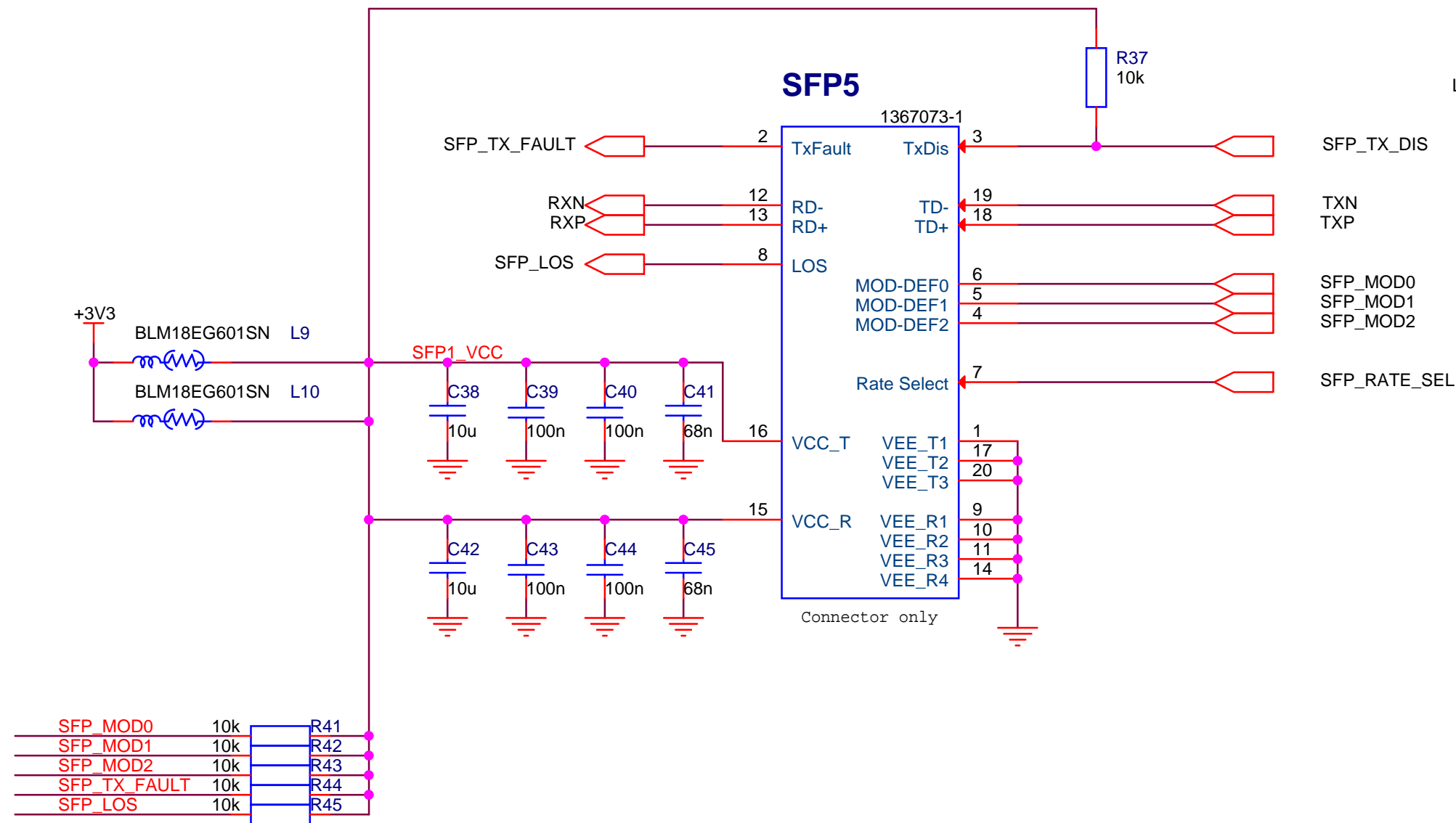

MODDEF0 is grounded by module when inserted

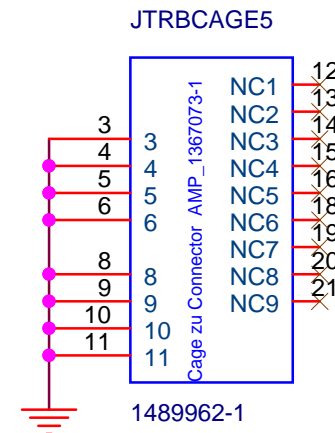

GbE

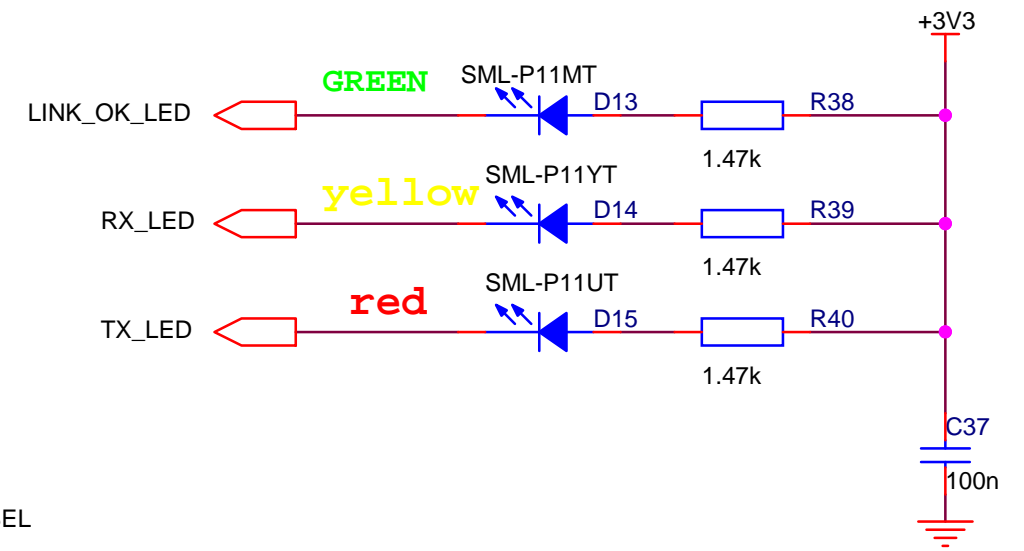

GSi Gesellschaft für Schwerionenforschung mbH
 Planckstrasse 1
 D-64291 Darmstadt
 GERMANY
 www.gsi.de

SFP

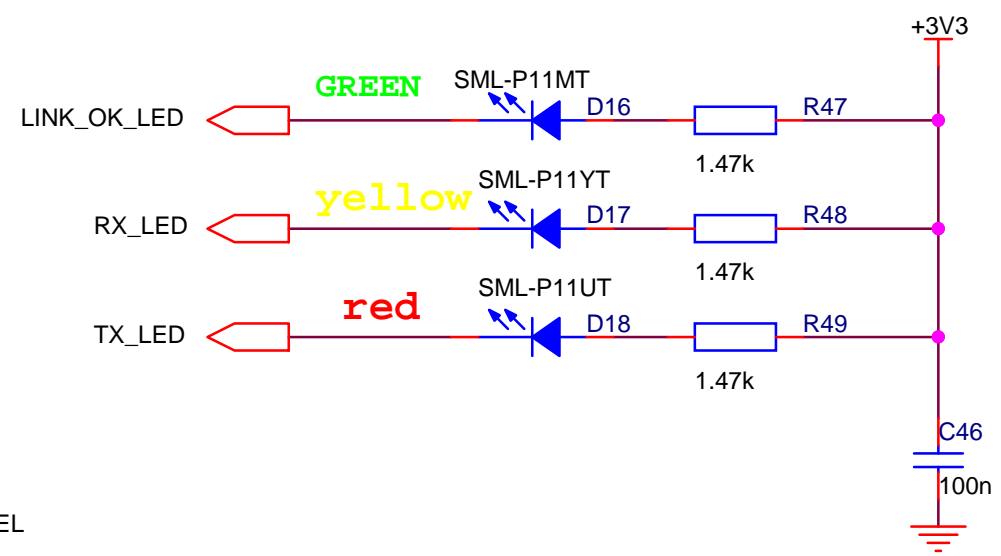
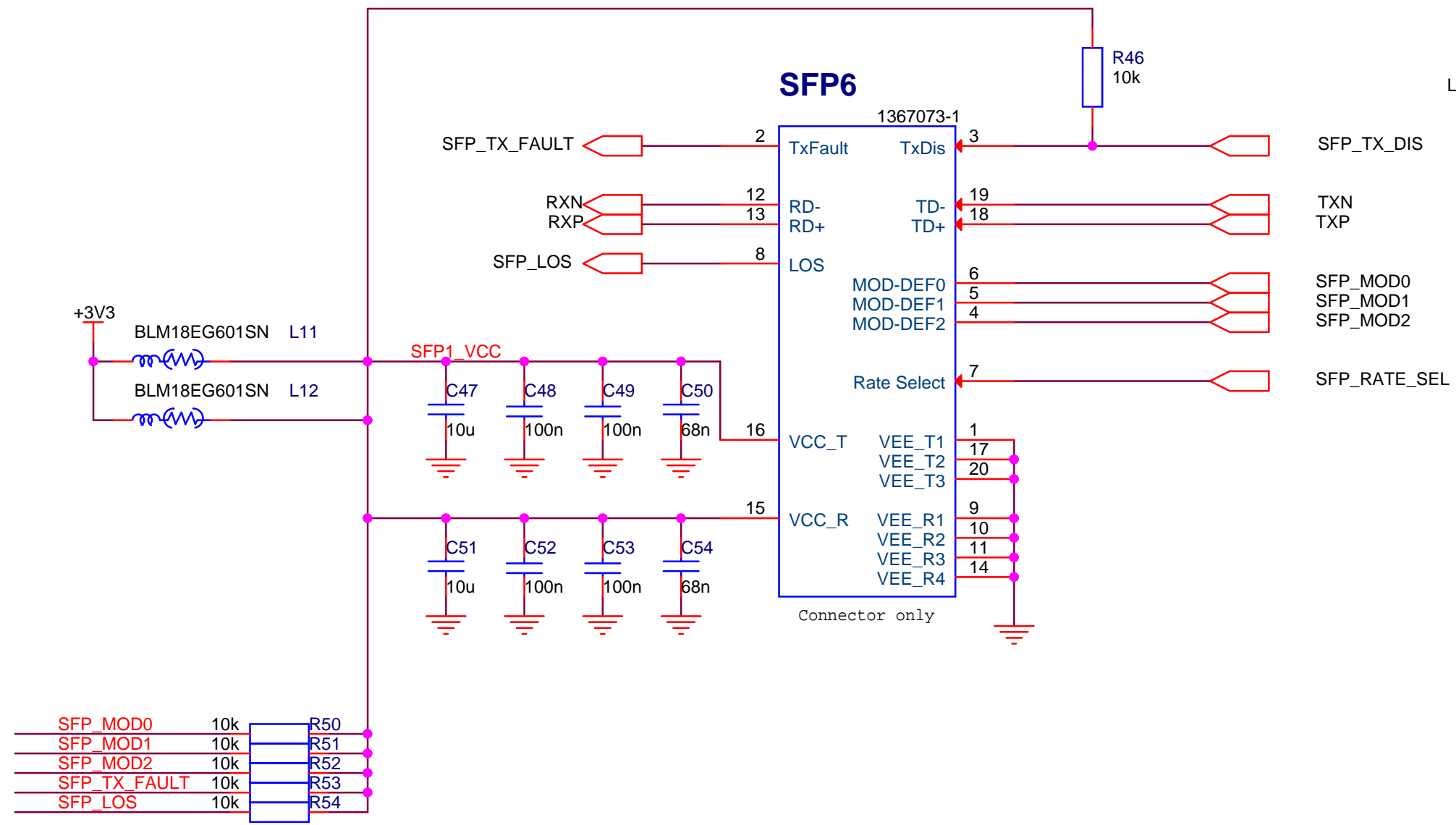

MODDEF0 is grounded by module when inserted

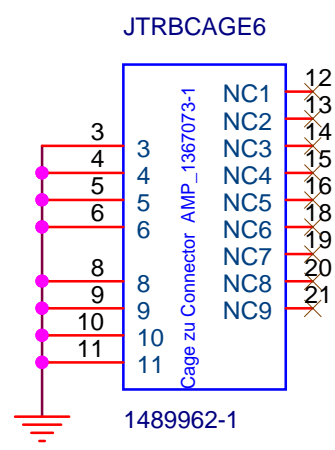

GbE

GSi Gesellschaft für Schwerionenforschung mbH
 Planckstrasse 1
 D-64291 Darmstadt
 GERMANY
 www.gsi.de

SFP

GSI-DA
SFP-Addon1
01.2012/MT/SV

SFP6

SFP5

SFP4

SFP3

SFP2

SFP1

[]

[]

[]

[]

[]

[]

Jobname
SFP-Addon1

Date
01.2012

Designer
M.Kajetanowicz
M.Traxler

Layouter
S.Voltz

Layer Nickname

Sst

Layer Nickname

Ssb

Jobname	Date	Designer	Layouter
SFP-Addon1	01.2012	M.Kajetanowicz M.Traxler	S.Voltz

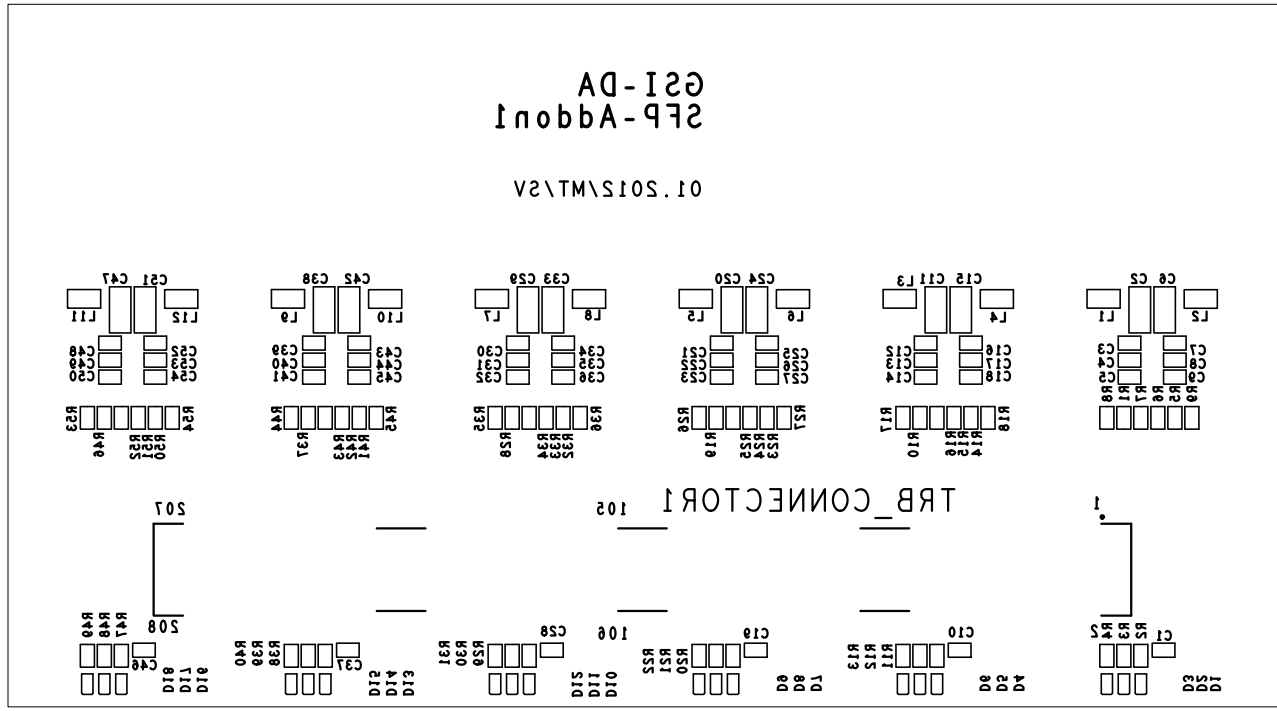

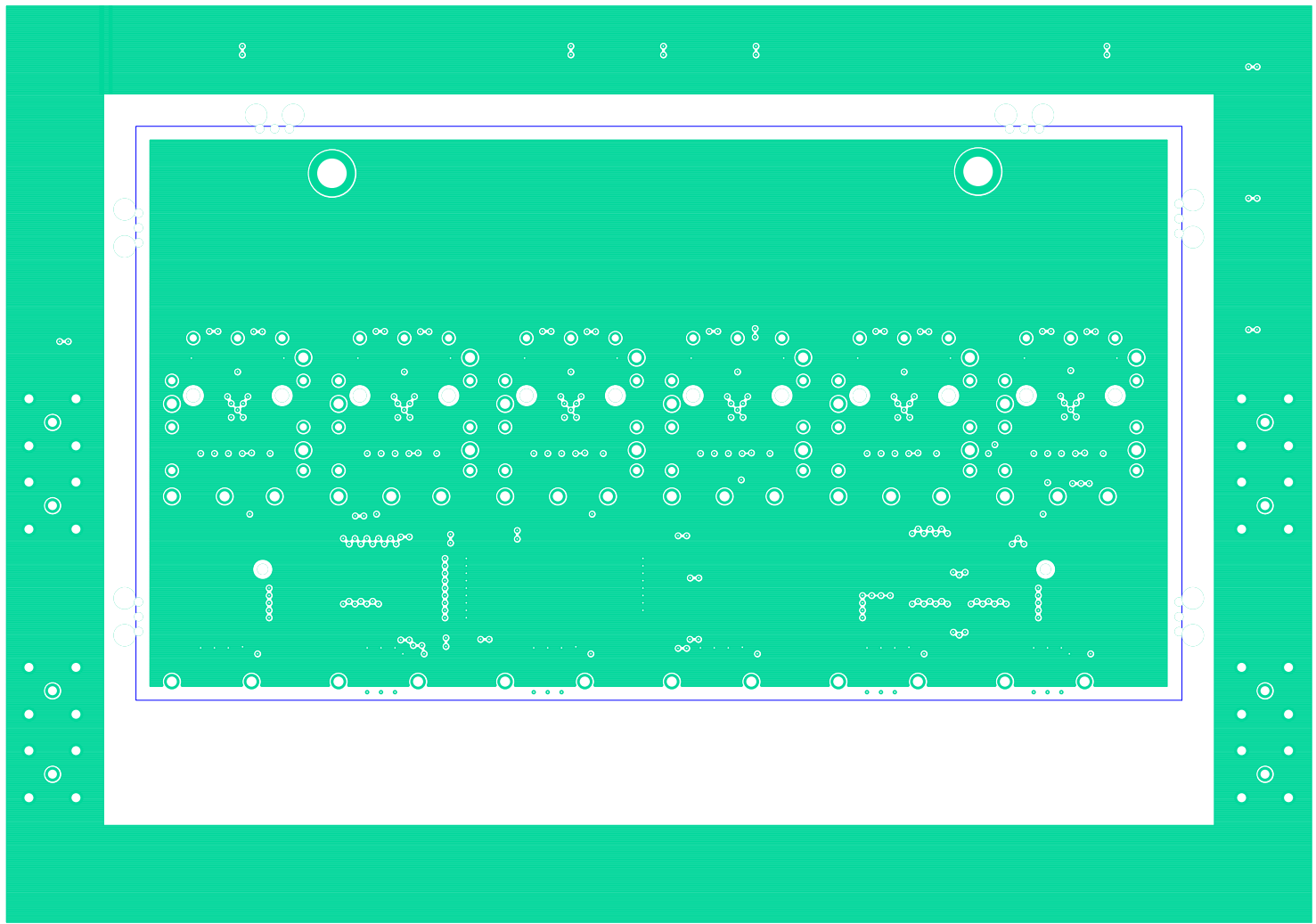

Jobname
SFP-Addon1

Date
01.2012

Designer
M.Kajetanowicz
M.Traxler

Layouter
S.Voltz

Layer Nickname

I04

IN4- +3.3V-Plane

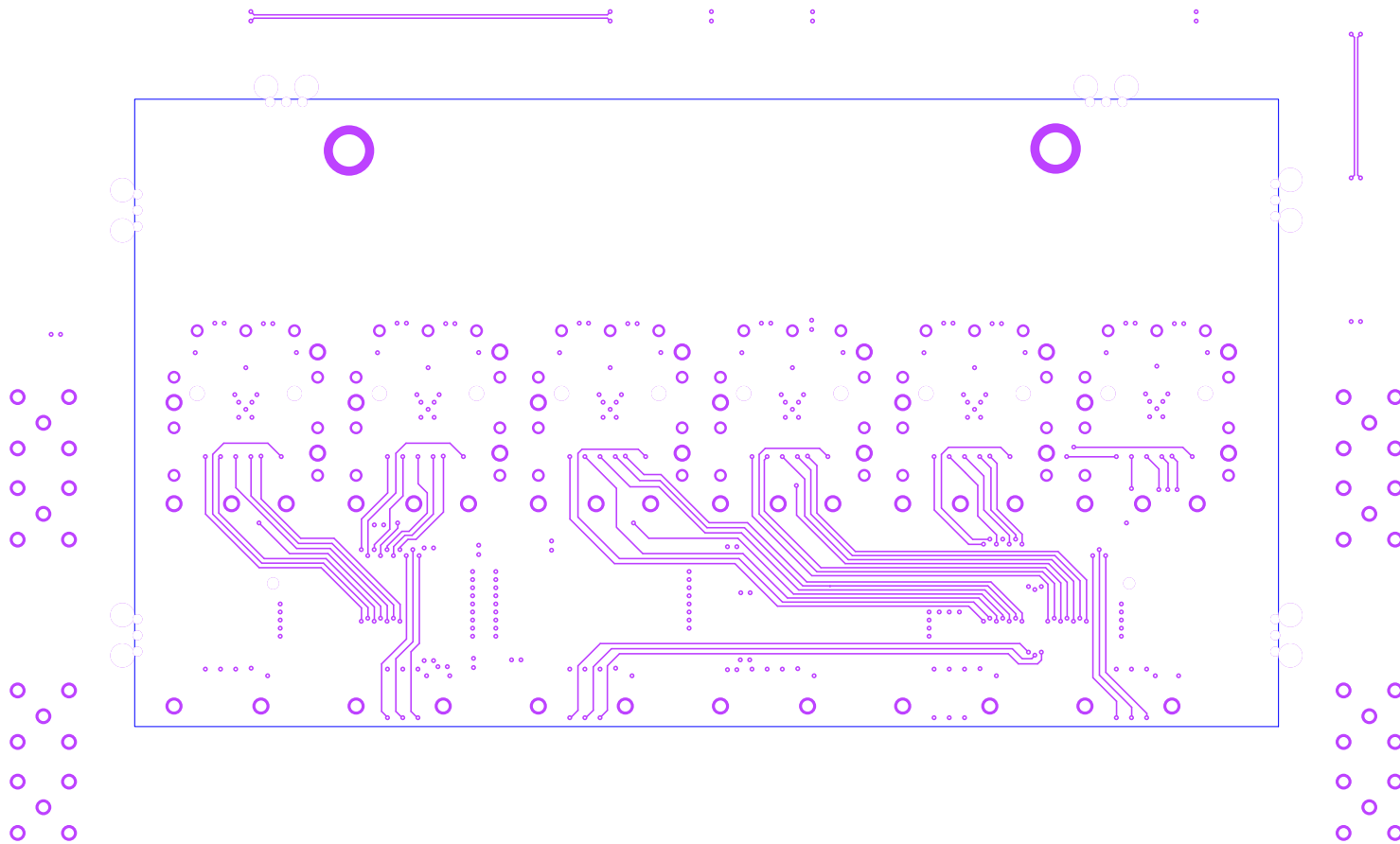

Jobname
SFP-Addon1

Date
01.2012

Designer
M.Kajetanowicz
M.Traxler

Layouter
S.Voltz

Layer Nickname

I03

IN3- Diff. Pairs, Signals

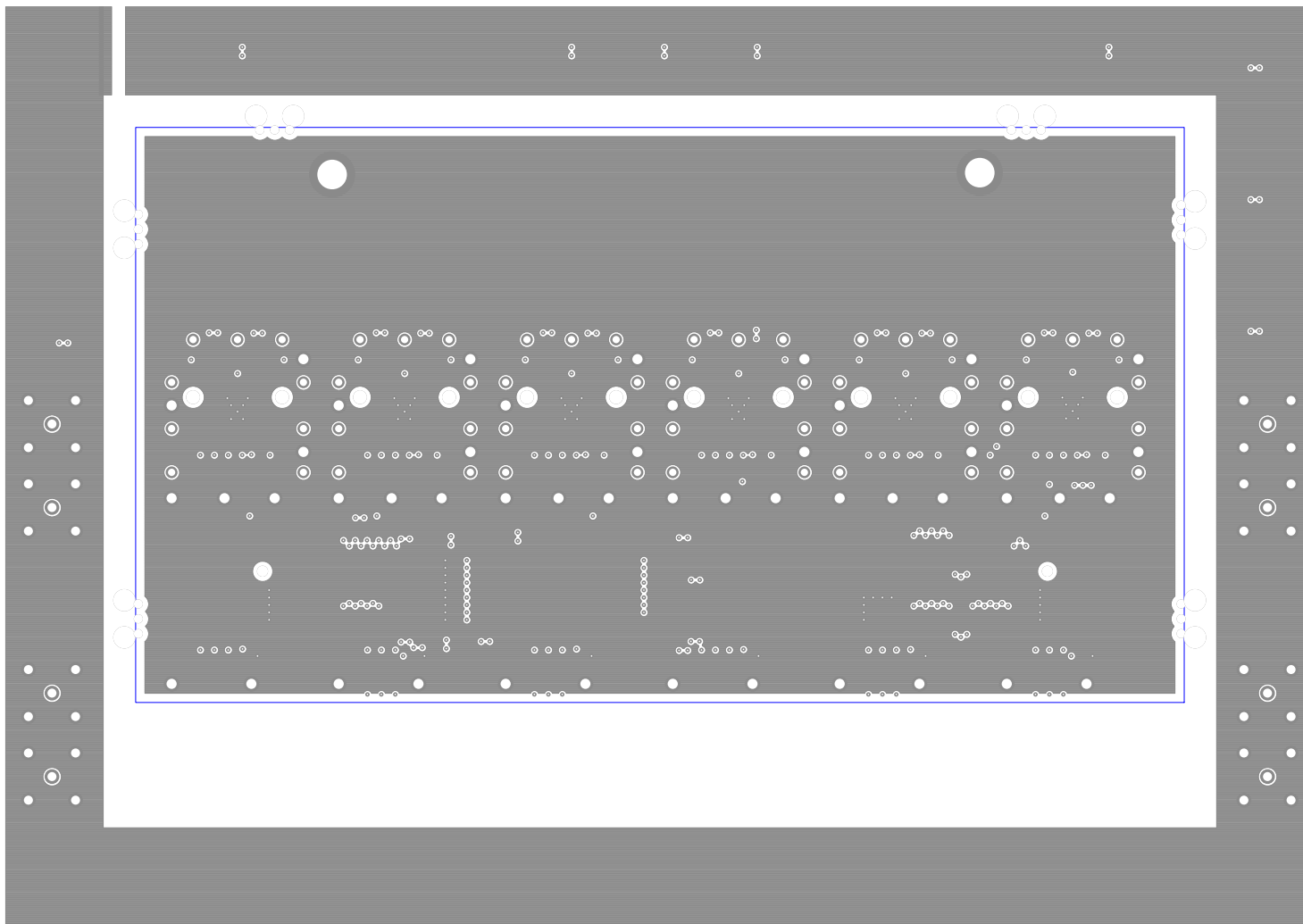

Jobname
SFP-Addon1

Date
01.2012

Designer
M.Kajetanowicz
M.Traxler

Layouter
S.Voltz

Layer Nickname

I02

IN2- Gnd-Plane

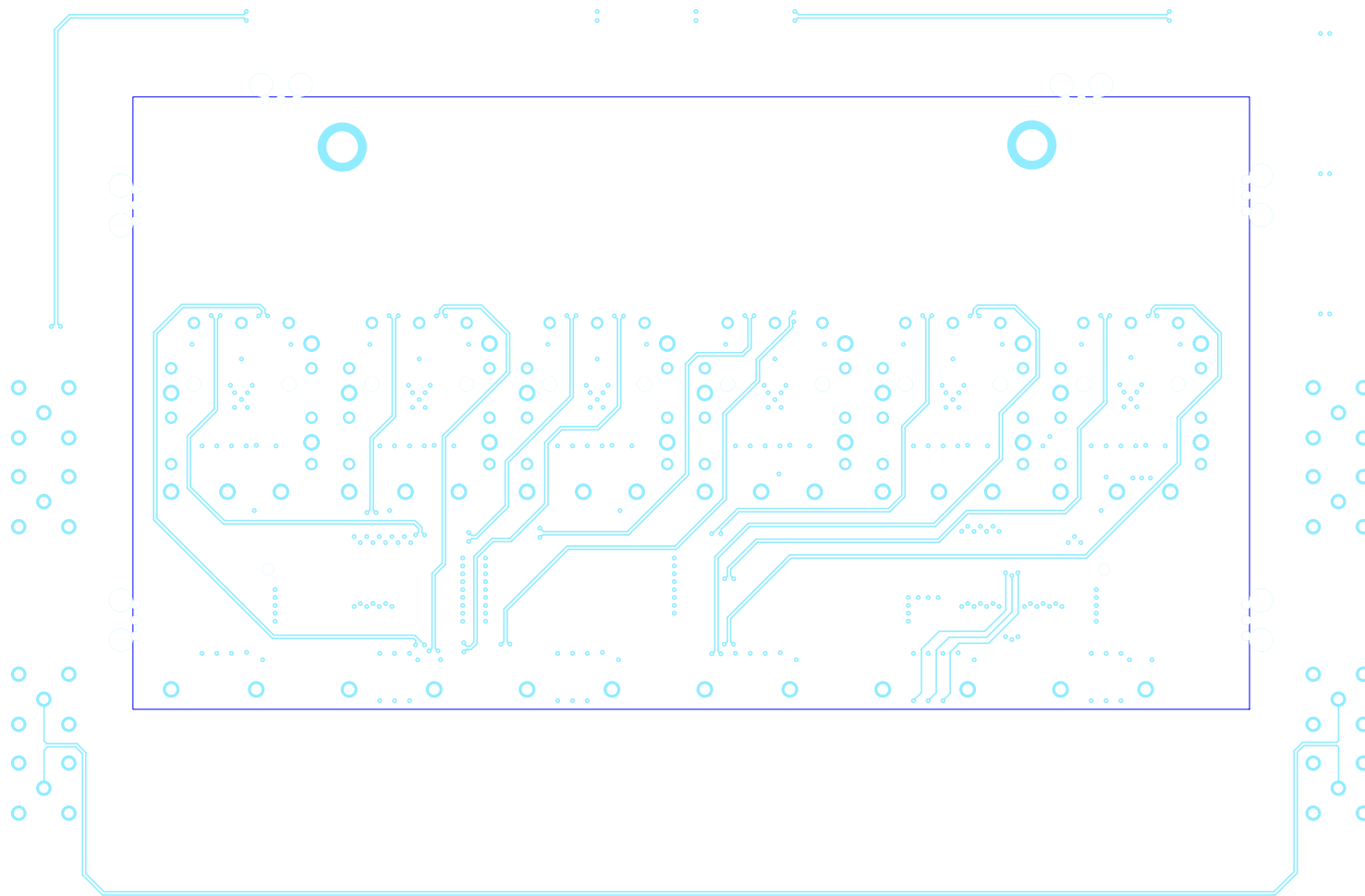

Jobname	Date	Designer	Layouter
SFP-Addon1	01.2012	M.Kajetanowicz M.Traxler	S.Voltz

Layer Nickname

I01

IN1- Diff.Pairs, Signals

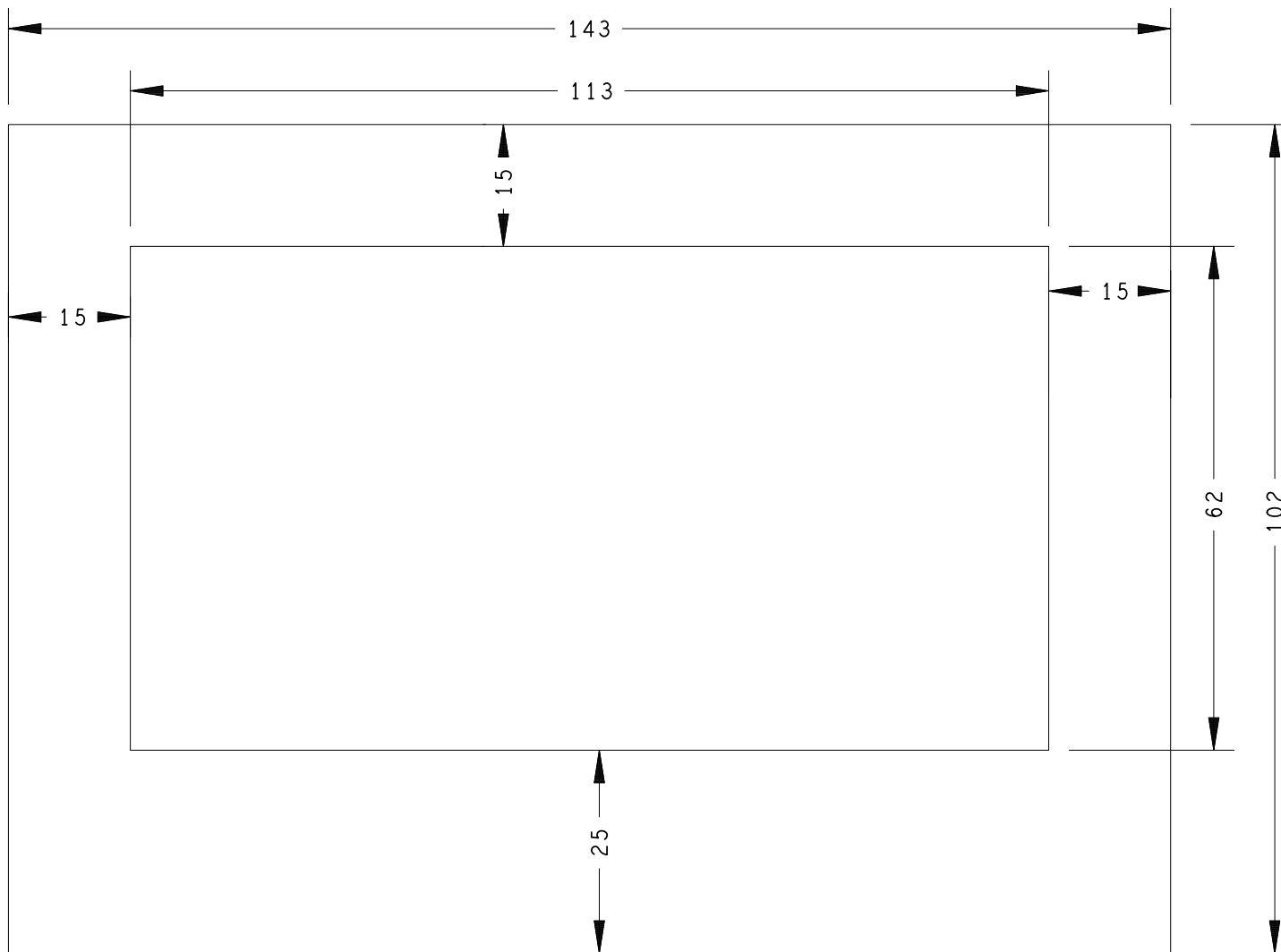

Jobname
SFP-Addon1

Date
01.2012

Designer
M.Kajetanowicz
M.Traxler

Layouter
S.Voltz

Layer Nickname

Fab

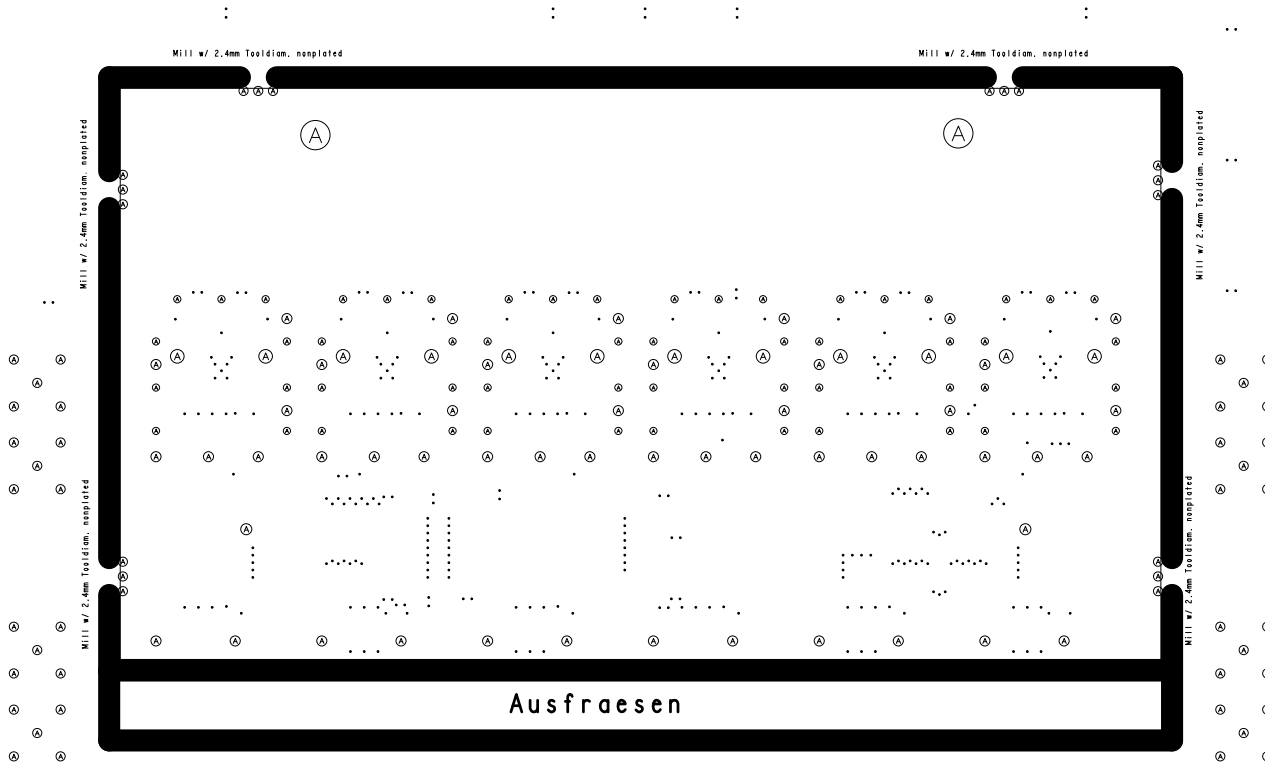

DRILL CHART: TOP to BOTTOM			
ALL UNITS ARE IN MILLIMETERS			
FIGURE	SIZE	PLATED	QTY
.	0.2	PLATED	305
•	0.4	PLATED	1
◦	0.8	PLATED	54
⊙	1.0	PLATED	40
⊗	1.1	PLATED	48
⊕	3.2	PLATED	2
⊖	1.0	NON-PLATED	18
⊘	1.2	NON-PLATED	2
⊙	1.5	NON-PLATED	12
⊗	2.4	NON-PLATED	12

TOTAL HOLES: 494



Jobname	Date	Designer	Layouter
SFP-Addon1	01.2012	M.Kajetanowicz M.Traxler	S.Voltz

Layer Nickname

Drd

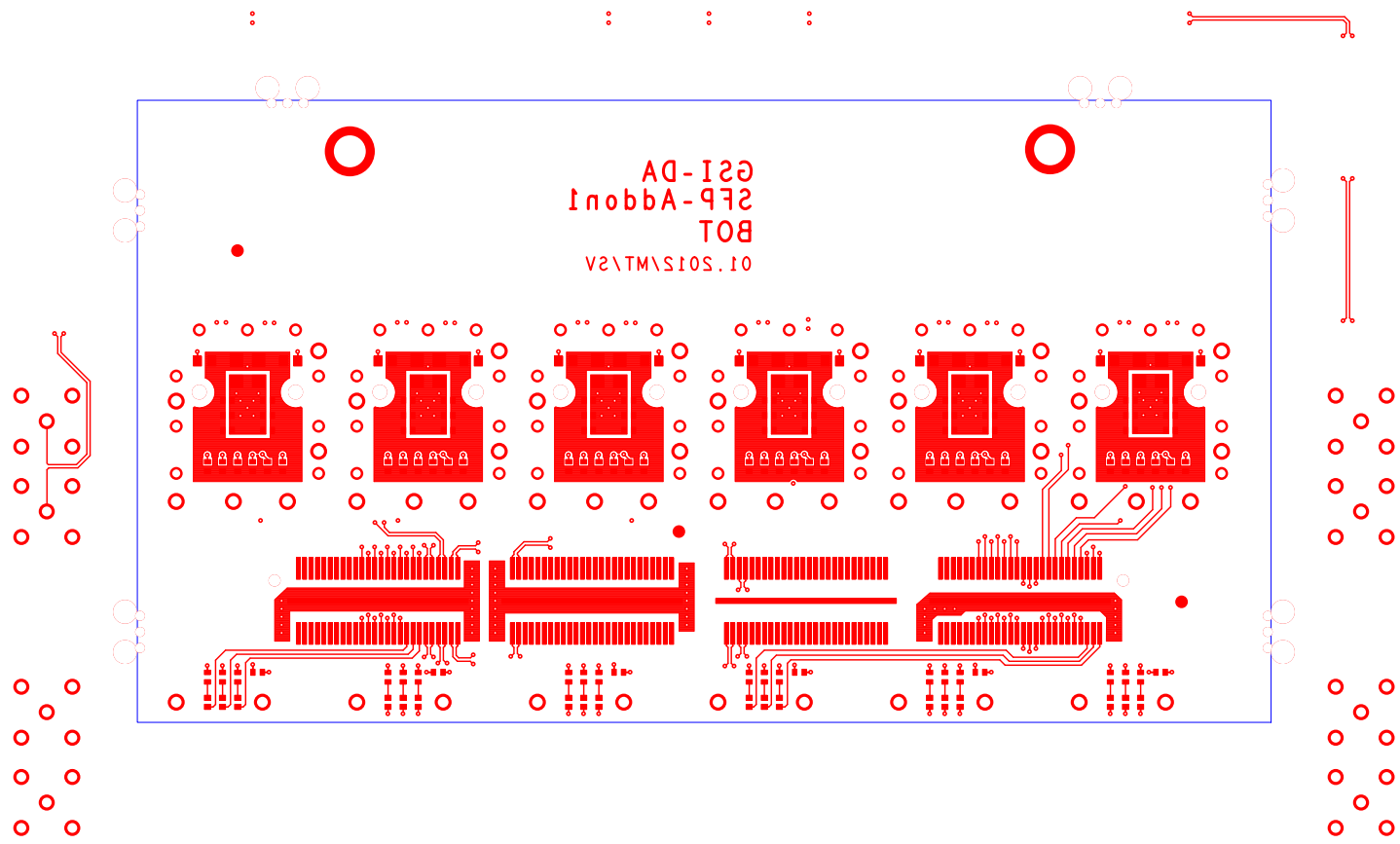

Jobname	Date	Designer	Layouter
SFP-Addon1	01.2012	M.Kajetanowicz	S.Voltz
		M.Traxler	

Layer Nickname
Bot

BOT- Signals

tkcautzad thcin nebrow 8-2AM2

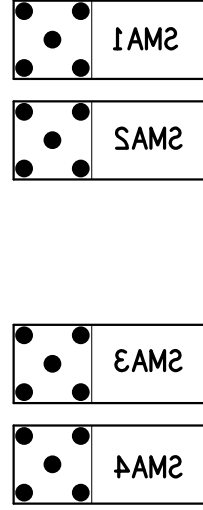
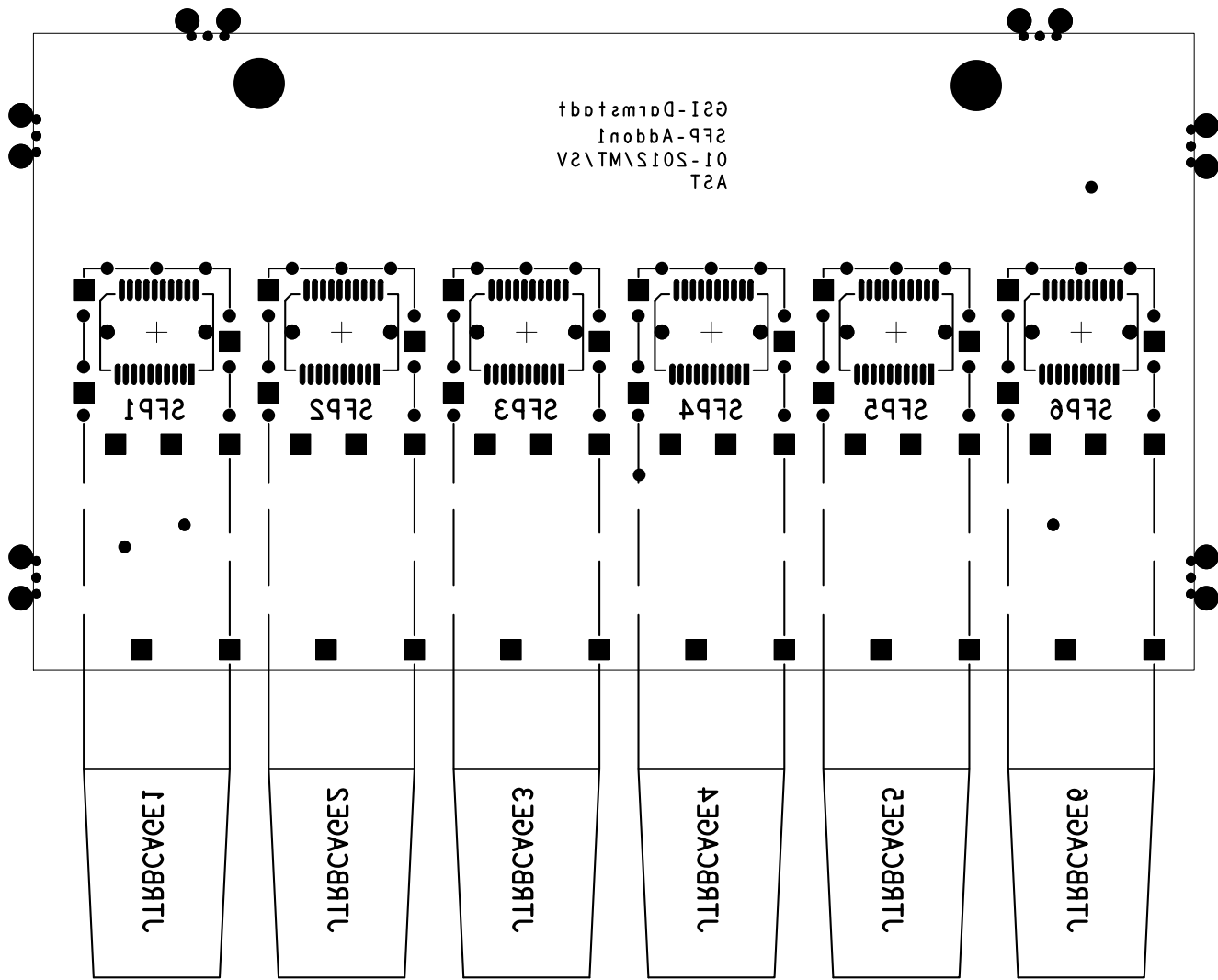
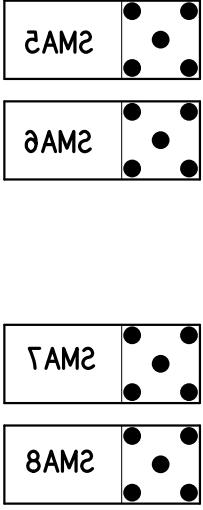

tkcautzad thcin nebrow 4-1AM2

Jobname SFP-Abdouni
 Date 01.2015
 Designer M.Kajetanowicz
 Layouter 2.Voltz

AS1
 01-S01S\MT\2V
 SFP-Abdouni
 2SI-Darstadt

As1

Голубицкий

GSI-Darmstadt
 SFP-Addon1
 01-2012/MT/SV
 ASB

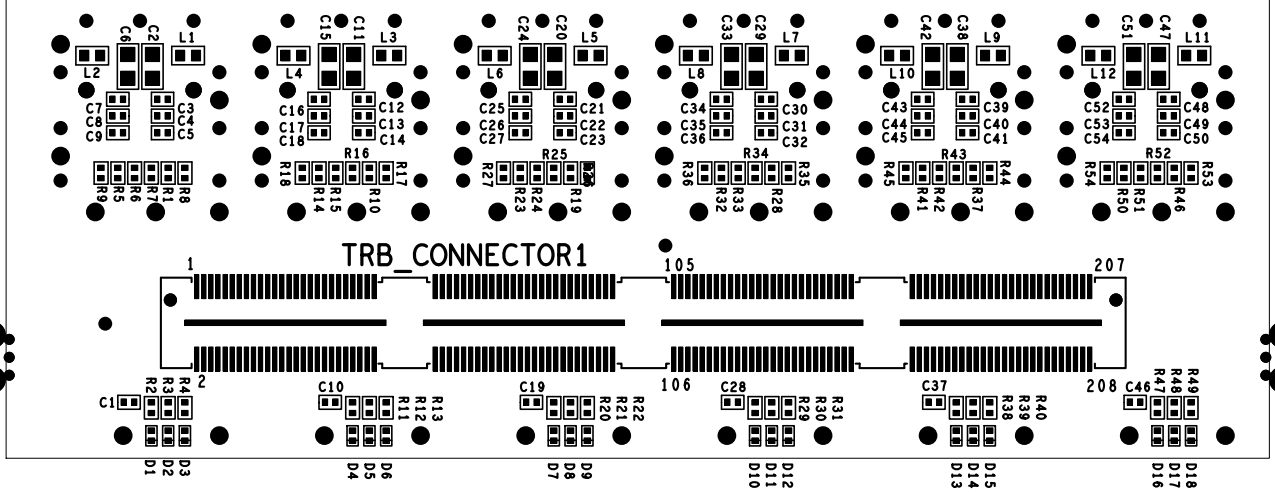

amanckin 19ydJ

Asp

Jobname SFP-Addon1
 Date 01.2012
 Designer M.Kajetanowicz
 Layer 2.Volts
 M.Traxler

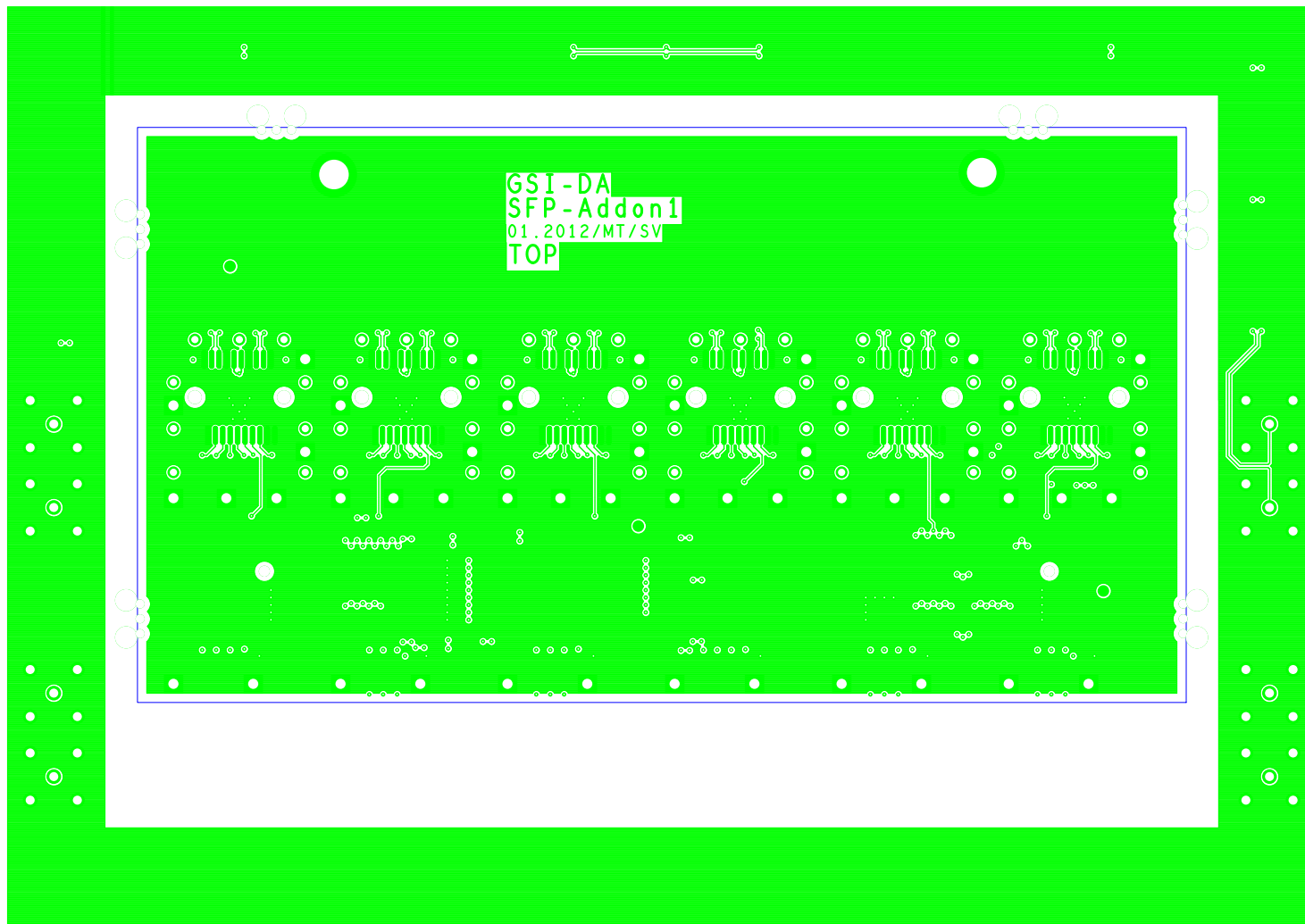

Jobname
SFP-Addon1

Date
01.2012

Designer
M.Kajetanowicz
M.Traxler

Layouter
S.Voltz

Layer Nickname

Top

TOP - GND-Plane

Multilayer

Entwurf_2_6Lg_Frau_Voltz

Material (mm)

Stack-Up

File

Assembly

(FR4 PP NP 155FB R:52 : 2116)

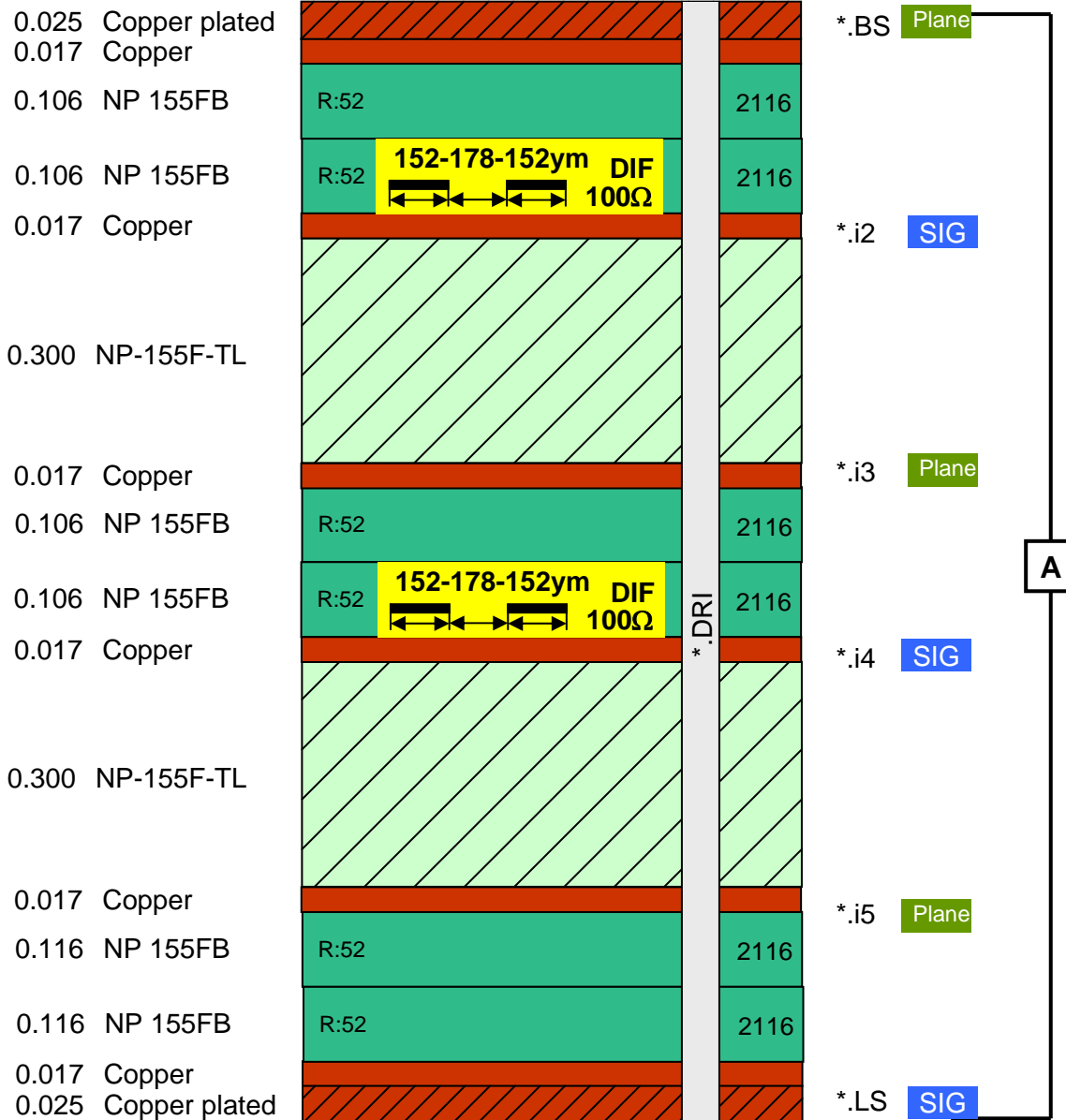

Thickness

(including soldermask and copperplating)

Bare Board	1.20 mm - 1.45mm
Immersion Tin	1.27 mm - 1.56mm
Hot-Air	1.30 mm - 1.58mm
Immersion Gold	1.26 mm - 1.55mm

Information

Document DOKU.MLT
 Drawing 10.03.2010/ GB
 Revision ----



VER