



Gesellschaft für Schwerionenforschung mbH  
Planckstrasse 1  
D-64291 Darmstadt  
GERMANY  
www.gsi.de

**01\_ERNI-Connector**

Design: K:\GSIJOB\COME AND KISS\CBM-RICH-FEE\CBM-RICH-FEE\1\CBM-R	Size: A3	Page: 1 / 7
Modified: Tuesday, April 03, 2012	Designer: M. Traxler	Layouter: S. Voltz

VIO=2.5V

VIO=2.5V

VIO=2.5V

VIO=2.5V

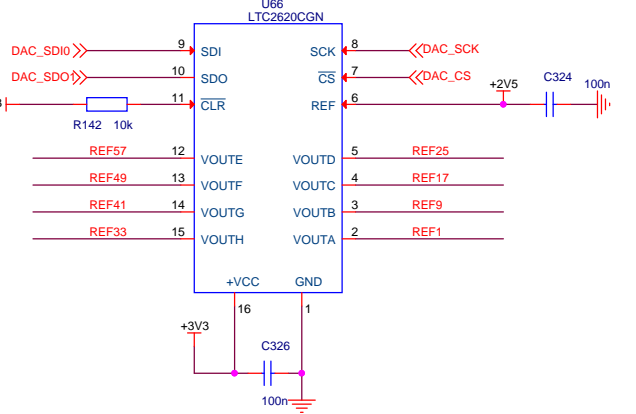
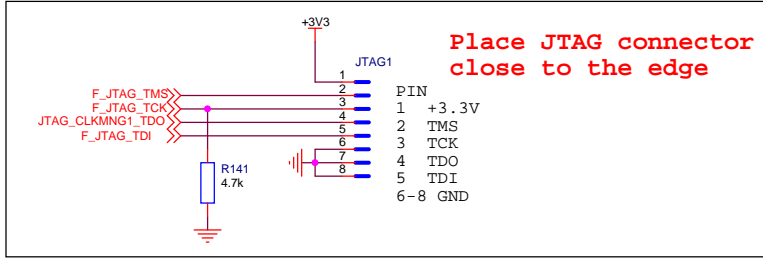
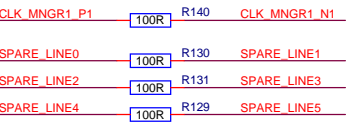
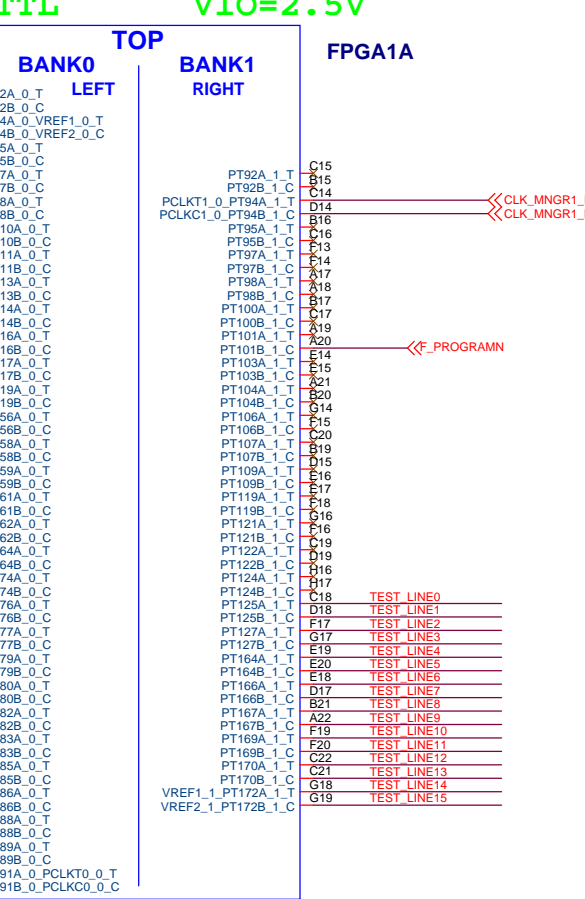
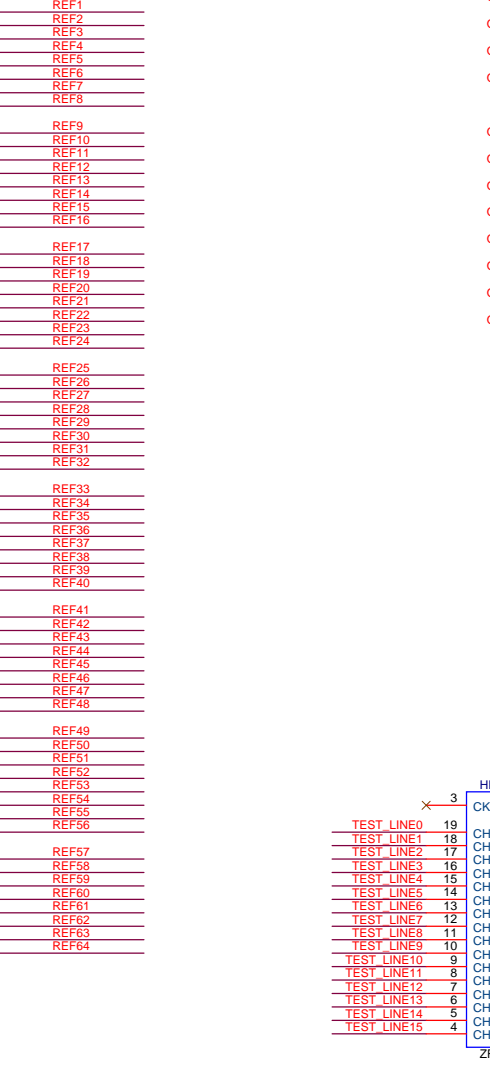
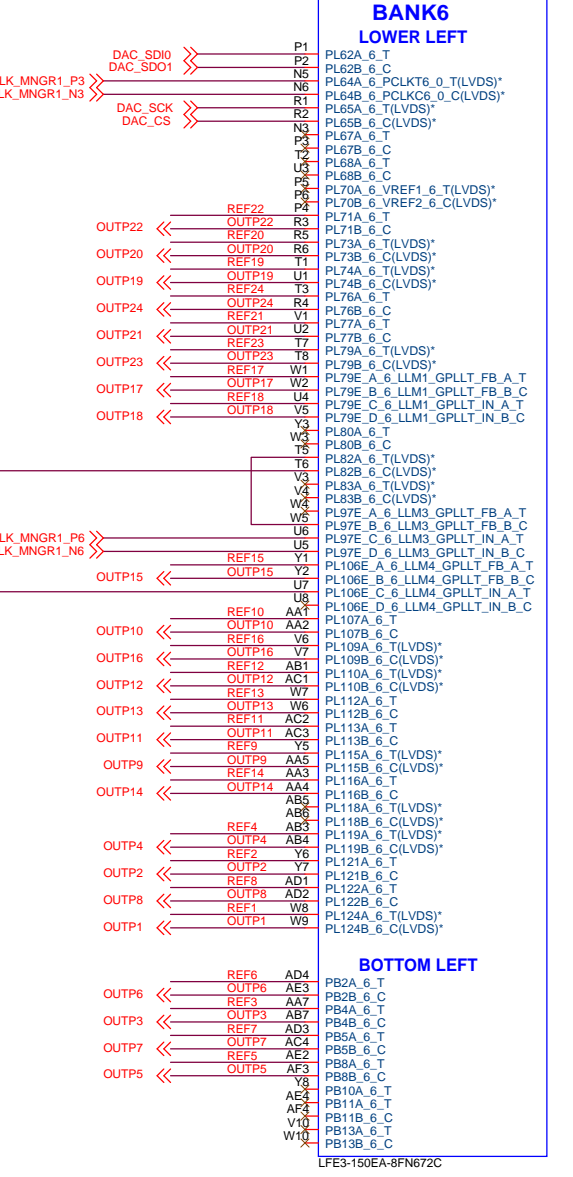
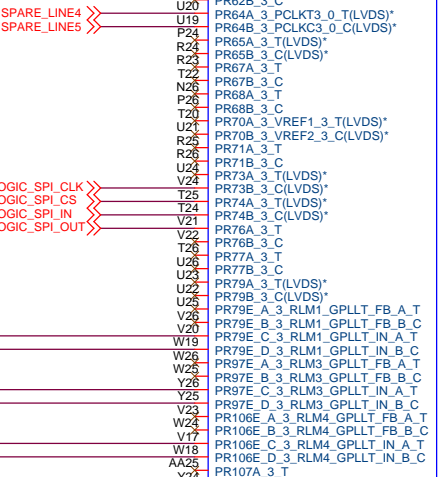
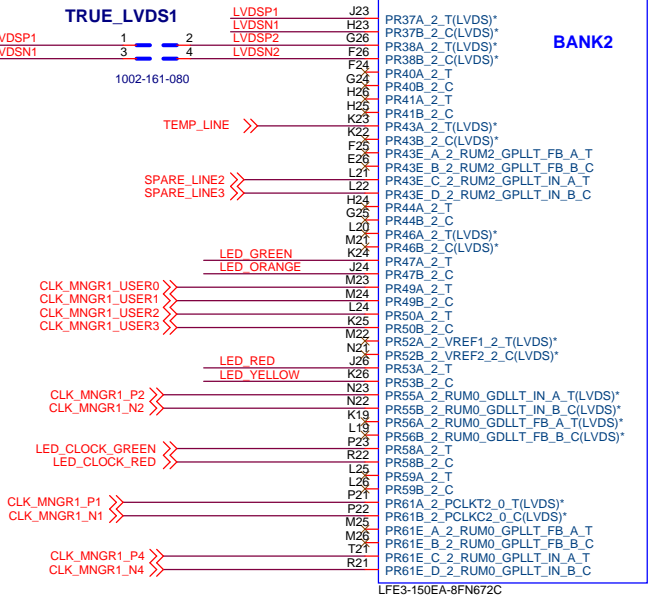
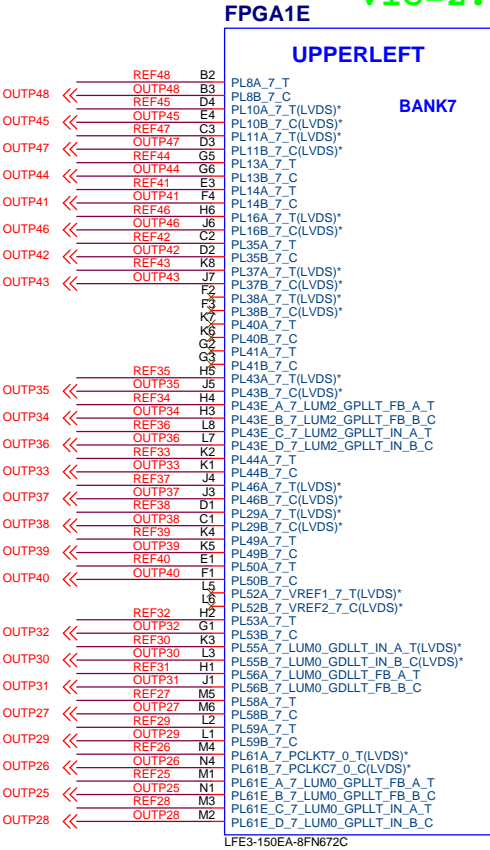

02\_FPGA-Logic

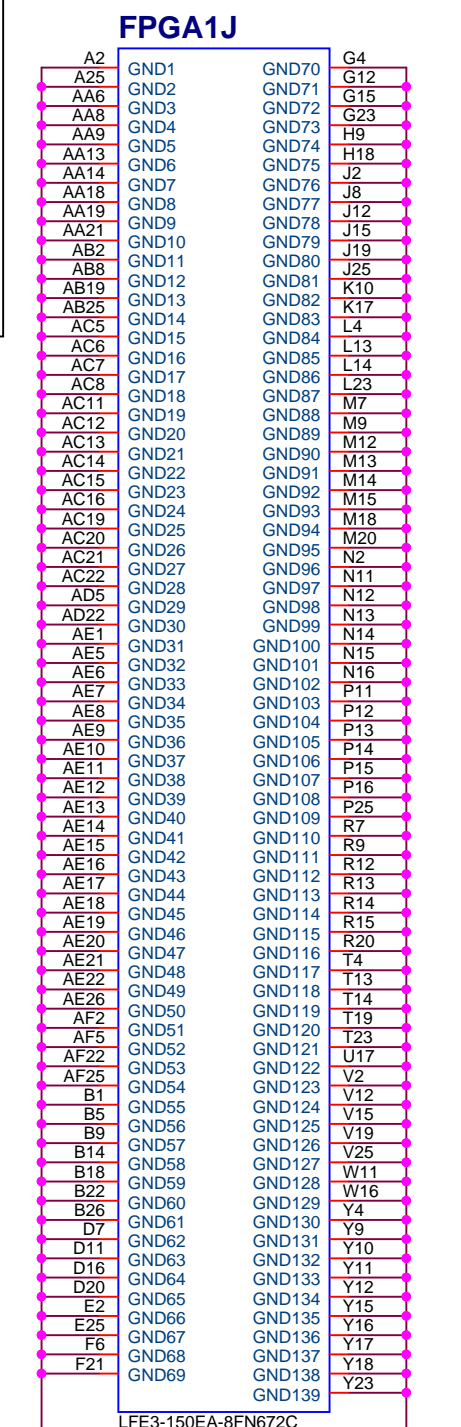
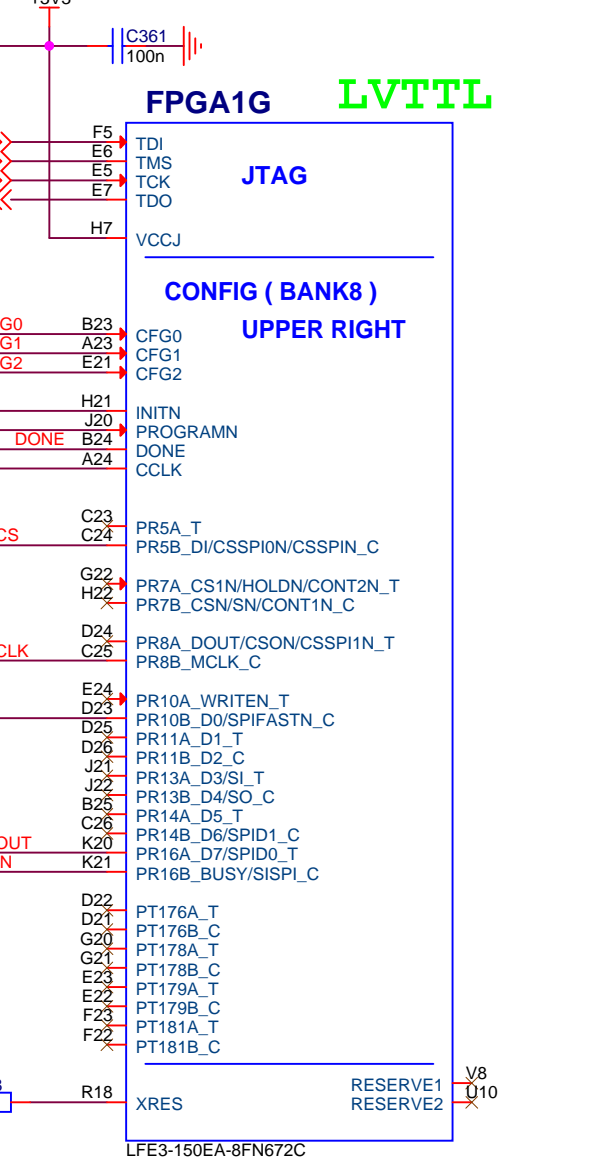
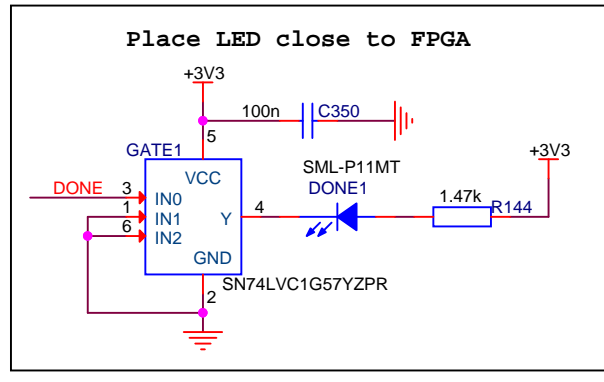
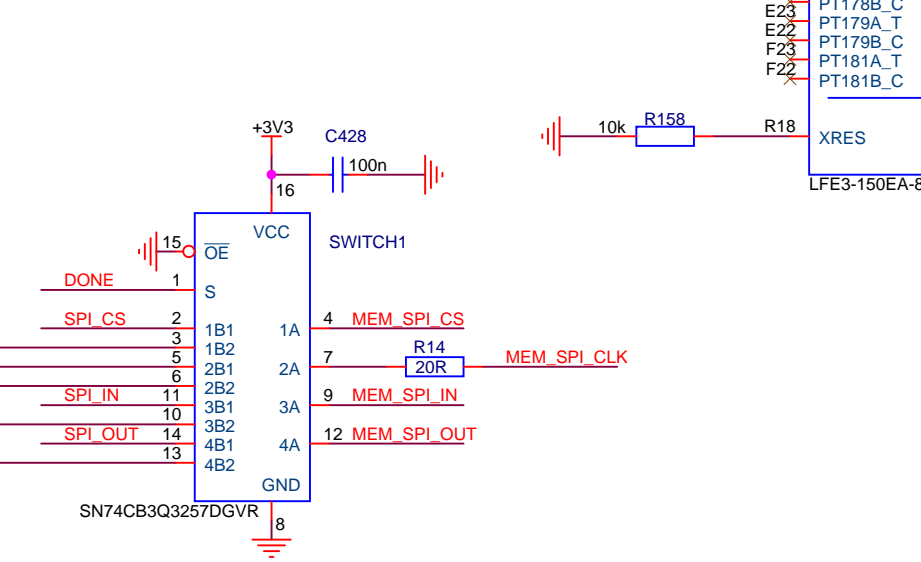
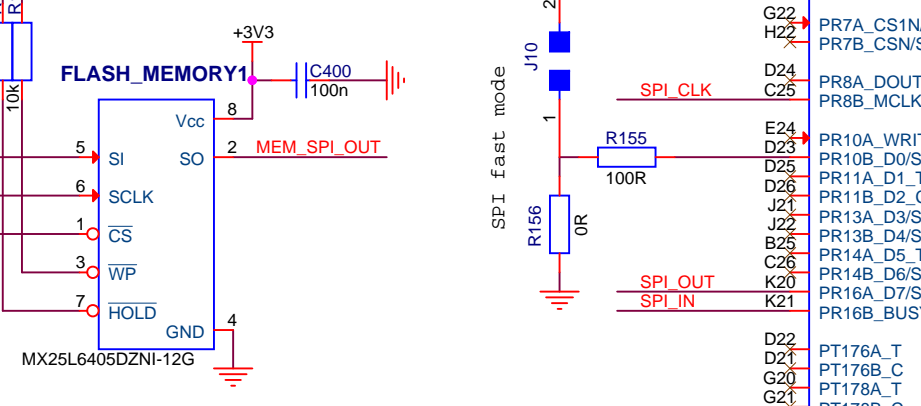
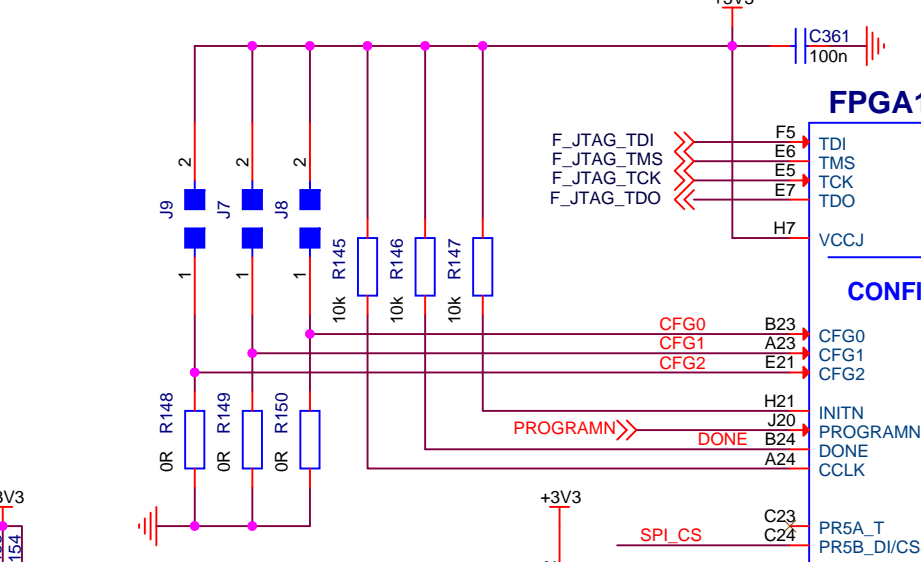
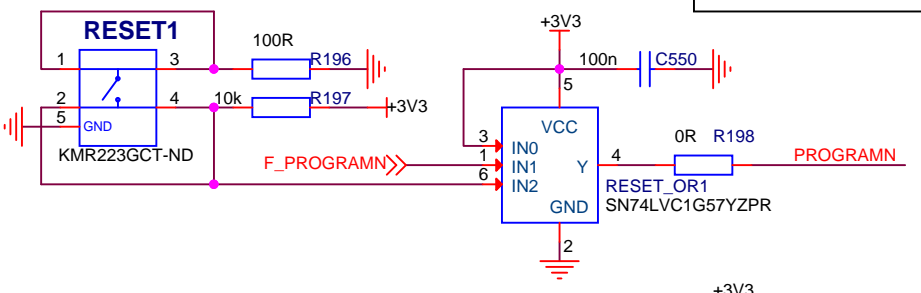
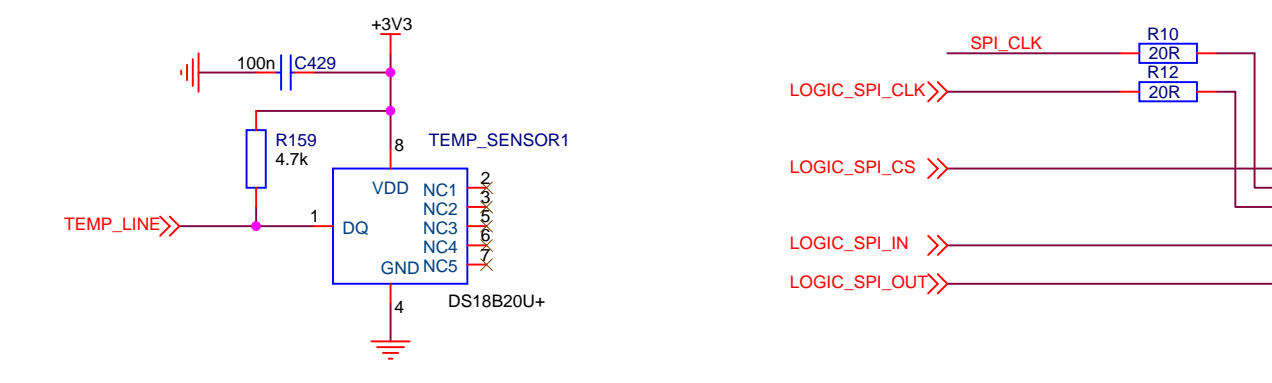
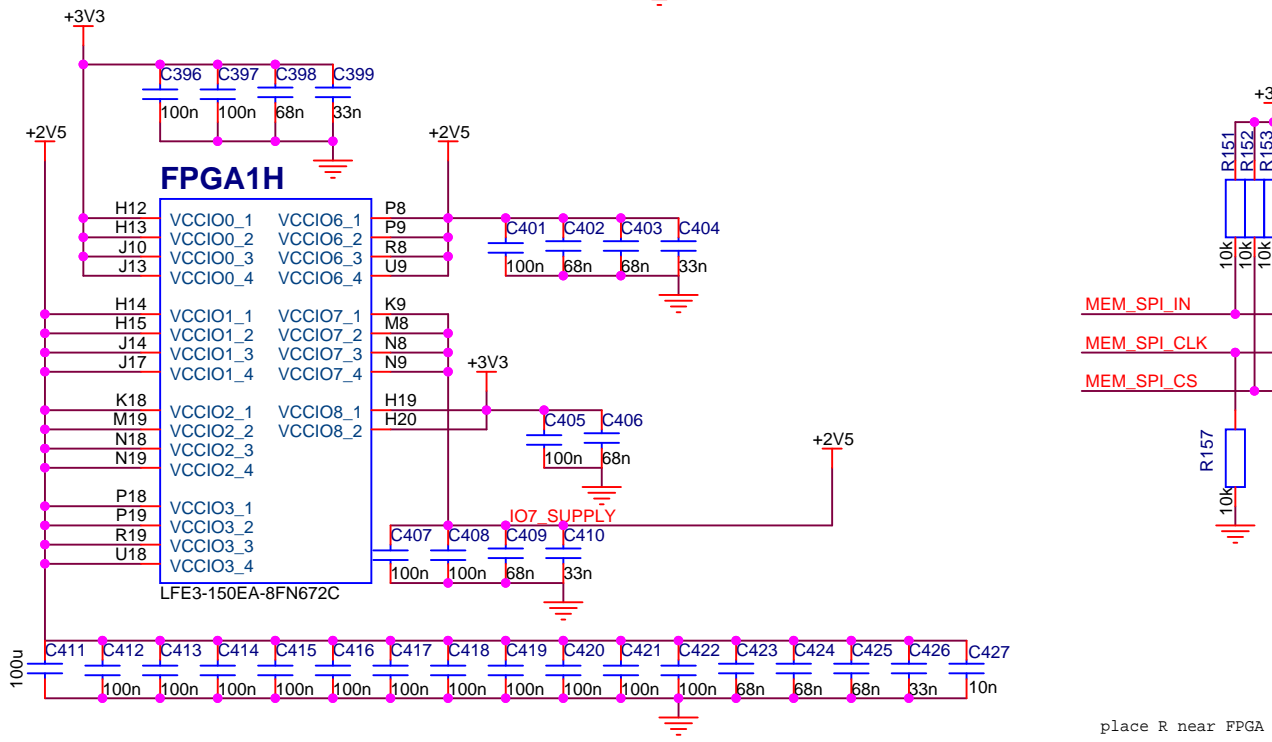
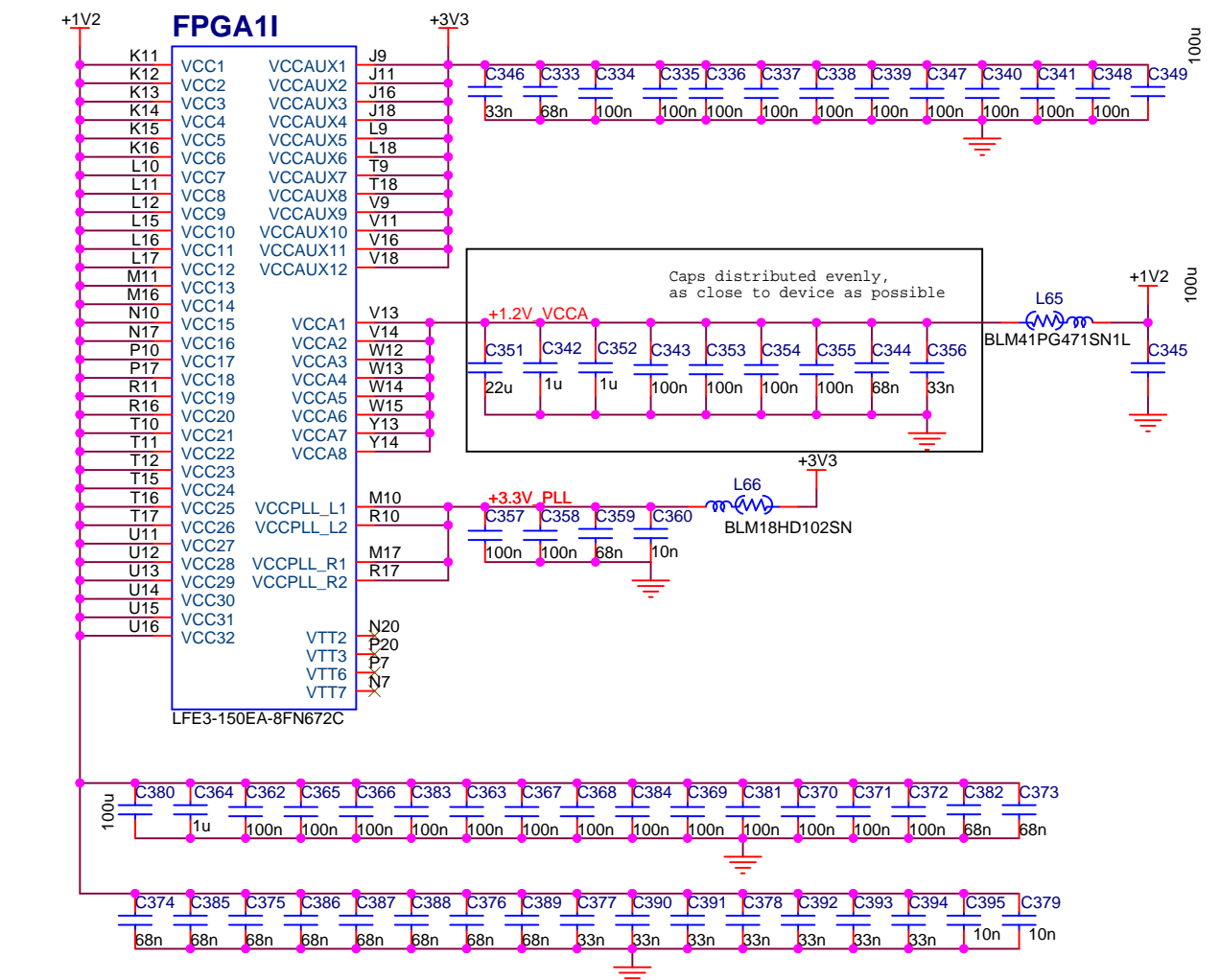

**GSII**

Gesellschaft für Schwerionenforschung mbH  
Planckstrasse 1  
D-64291 Darmstadt  
GERMANY  
www.gsi.de

**03\_FPGA-Power**

Design: K:\GSI\JOB\COME AND KISS\CBM-RICH-FEE\CBM-RICH-FEE\1\CBM-RICH-FEE-03\_FPGA-Power  
Modified: Tuesday, April 03, 2012  
Designer: M. Traxler

Size: A3  
Page: 4 / 7  
Layouter: S.Voltz

FPGA1F

SERDES  
BOTTOM

RIGHT 50 LEFT 51

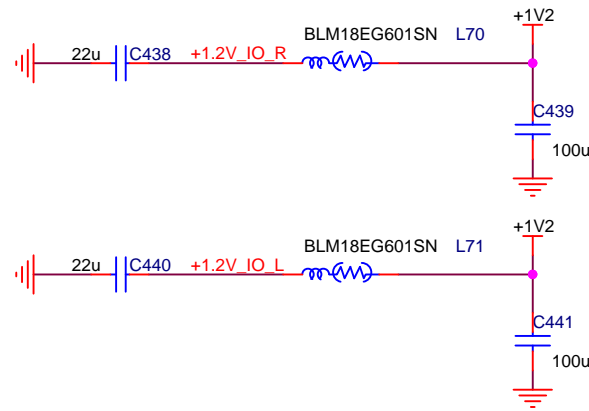
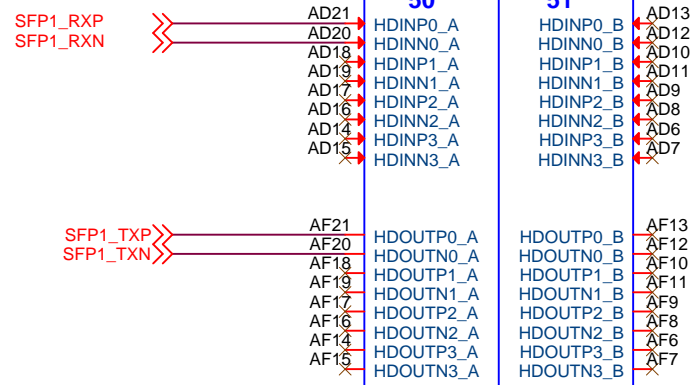

100Ohms here?  
offen bitte

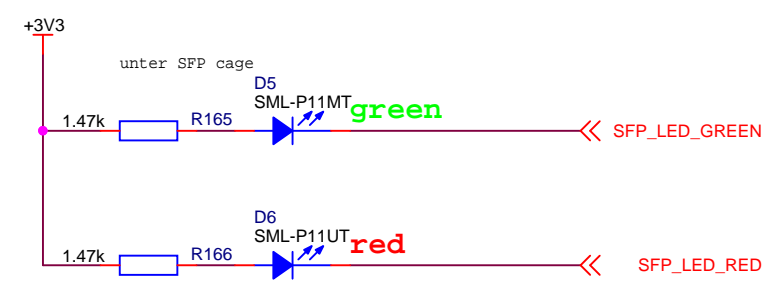
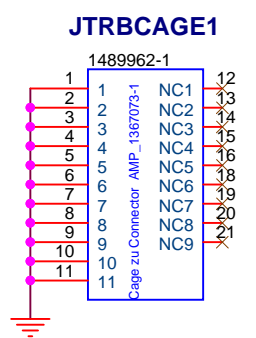
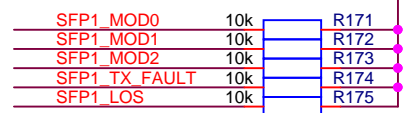
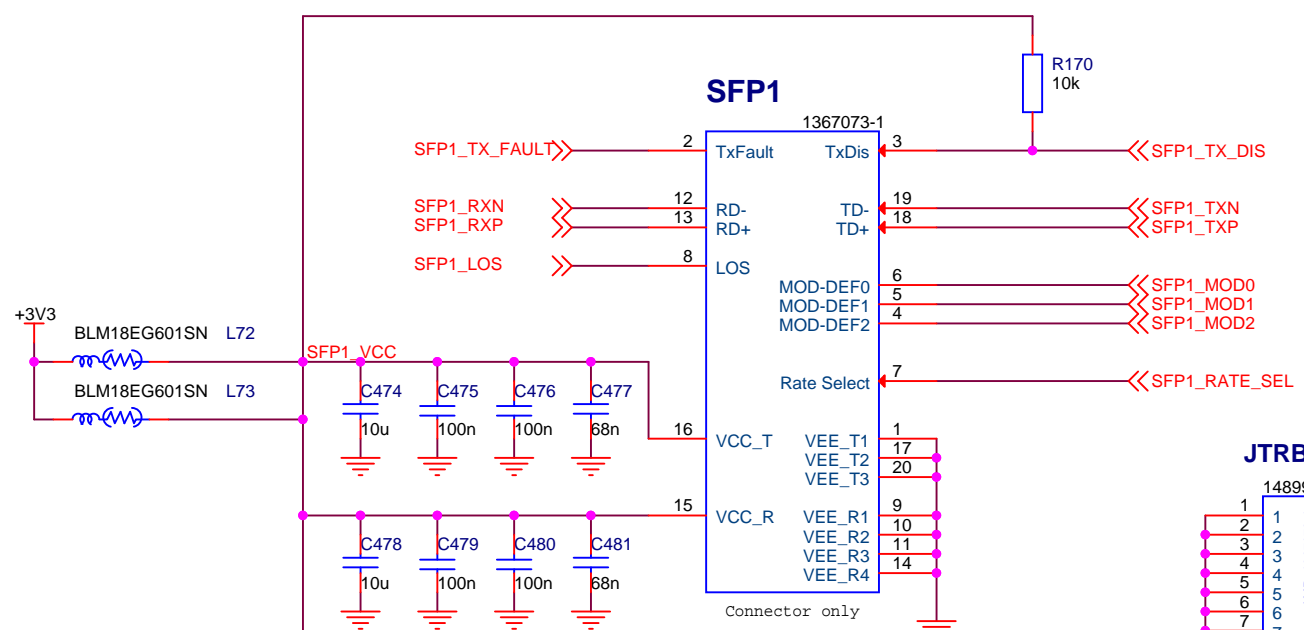
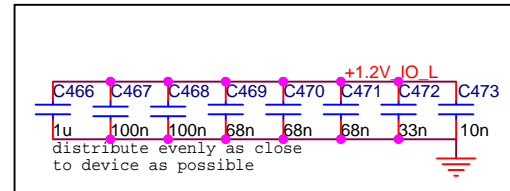
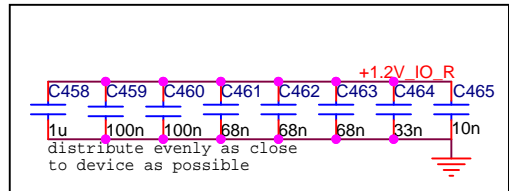
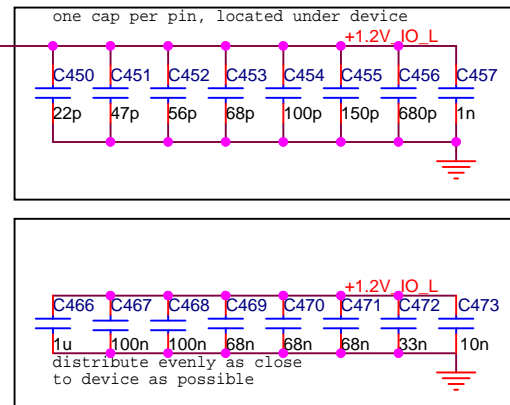
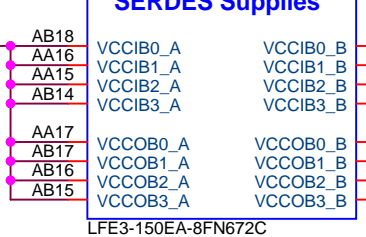
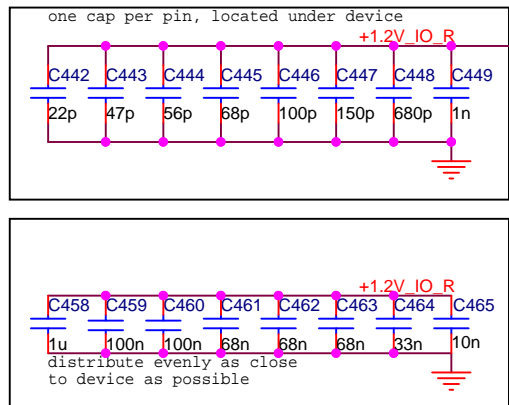

MODDEF0 is grounded by module when inserted

**GSI** Gesellschaft für Schwerionenforschung mbH  
Planckstrasse 1  
D-64291 Darmstadt  
GERMANY  
www.gsi.de

**04\_SERDES + SFP**

Design: K:\GSI\JOB\COME AND KISS\CBM-RICH-FEE\CBM-RICH-FEE\1CBM-RICH-FEE-04\_SERDES + SFP  
Modified: Tuesday, April 03, 2012  
Designer: M. Traxler

Size: A3  
Page: 5 / 7  
Layouter: S. Voltz

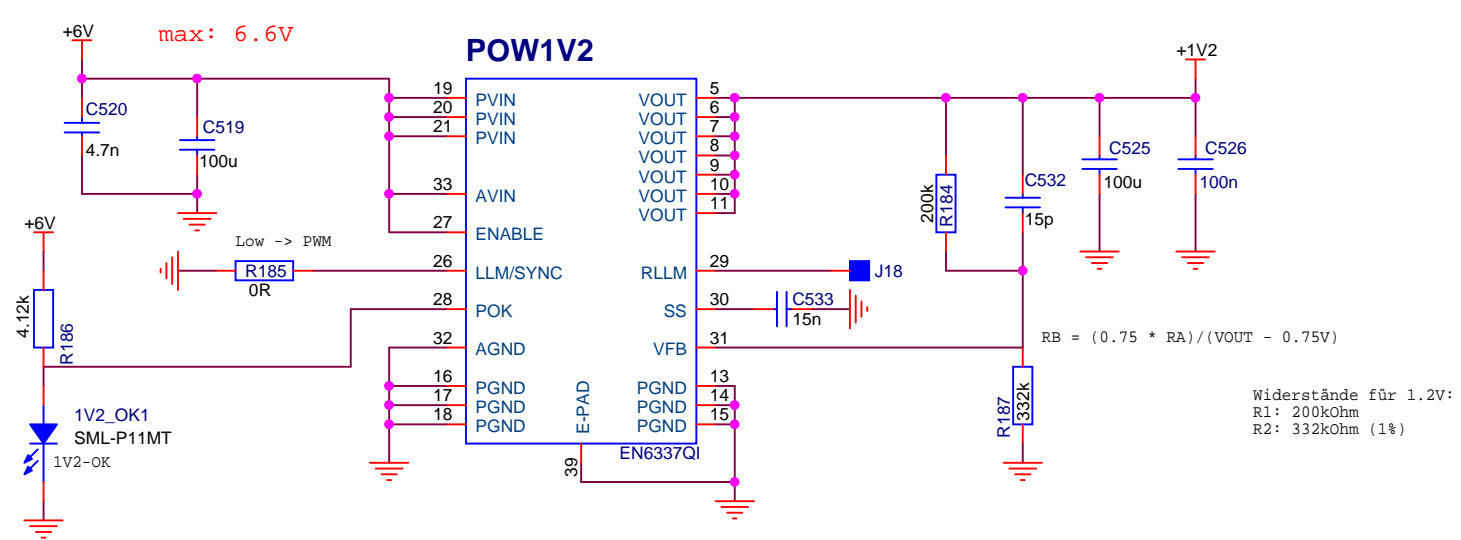
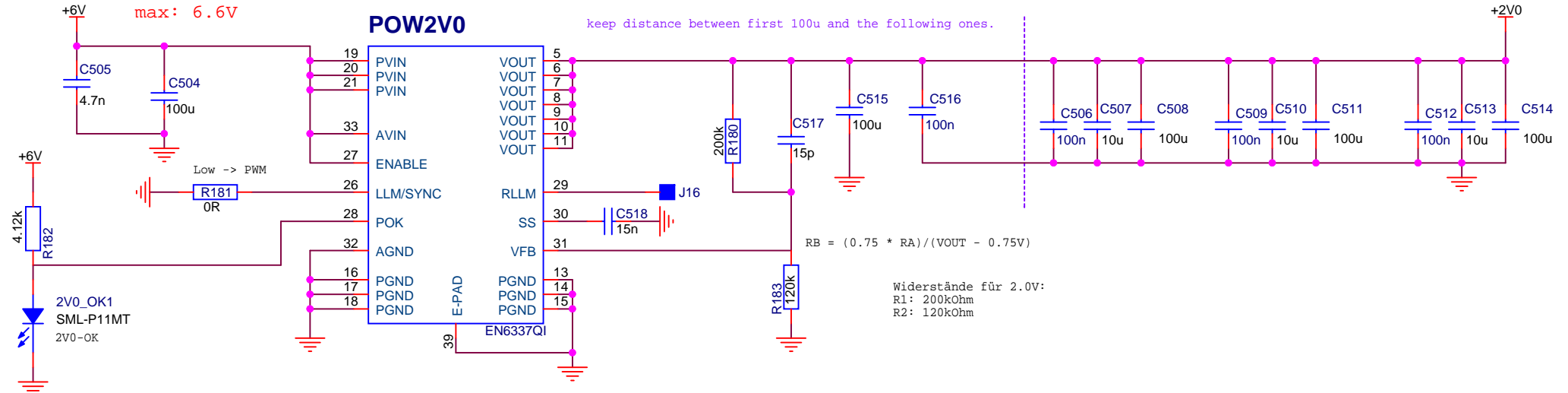
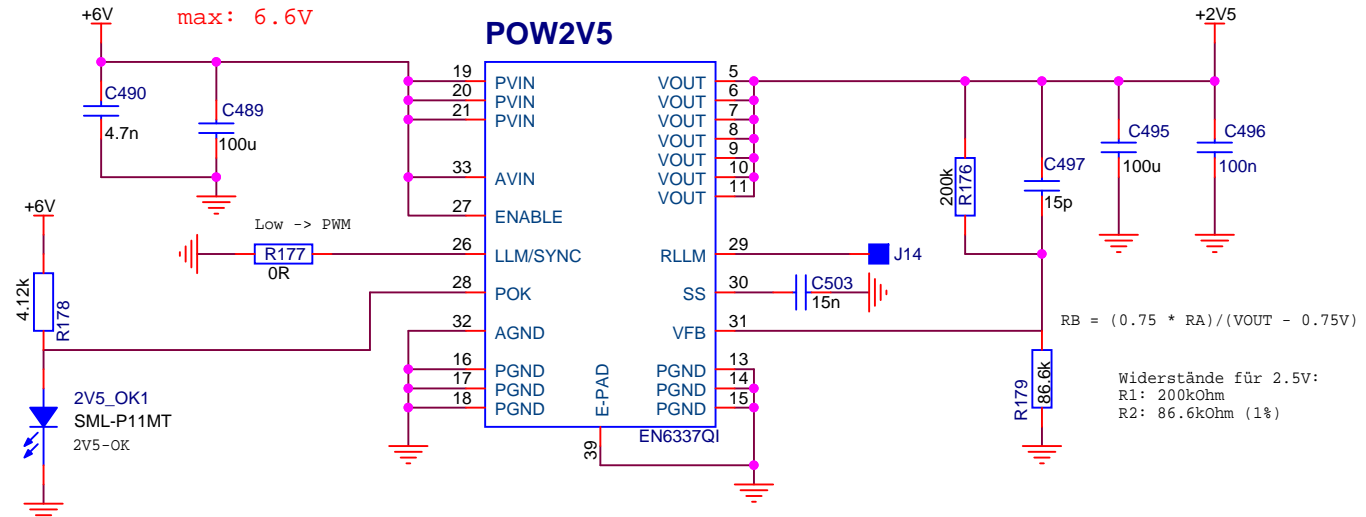
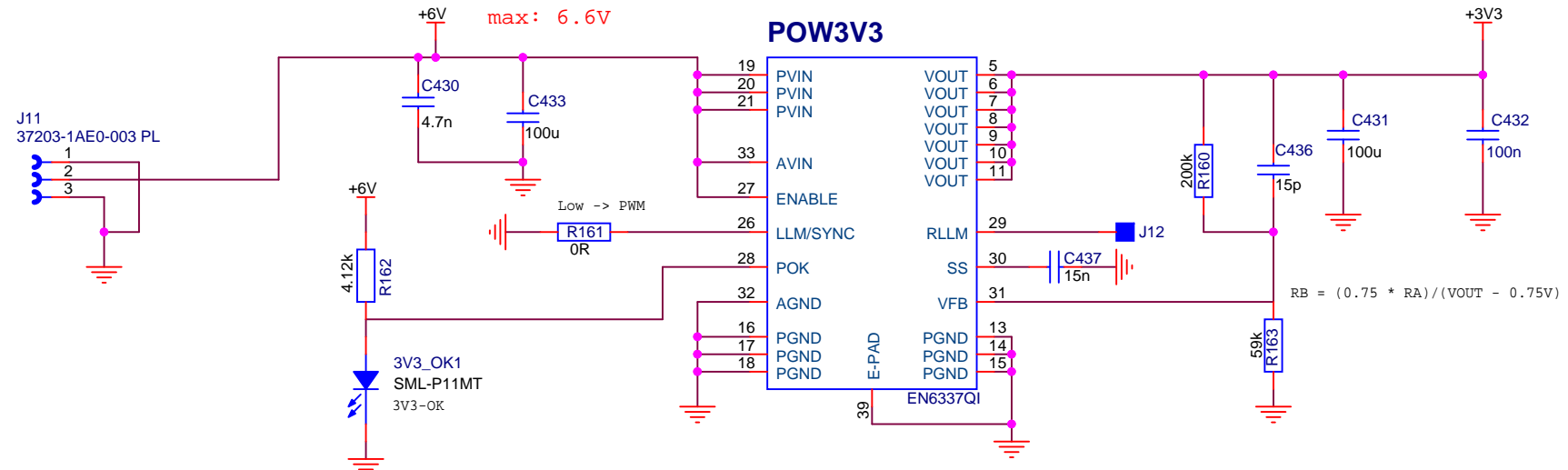

**GSI** Gesellschaft für Schwerionenforschung mbH  
Planckstrasse 1  
D-64291 Darmstadt  
GERMANY  
www.gsi.de

**05\_Power**

Design: K:\GSI\JOB\COME AND KISS\CBM-RICH-FEE\CBM-RICH-FEE\1CBM-RICH-FEE-05\_Power  
Modified: Tuesday, April 03, 2012  
Designer: M. Traxler

Size: A3  
Page: 6 / 7  
Layouter: S.Voltz



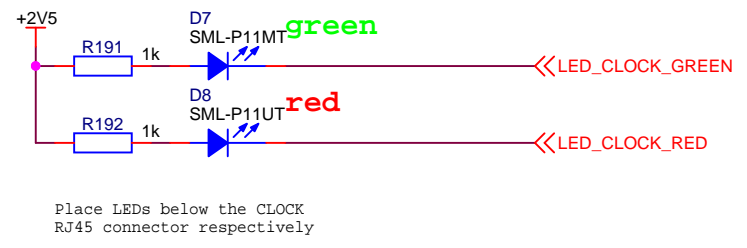
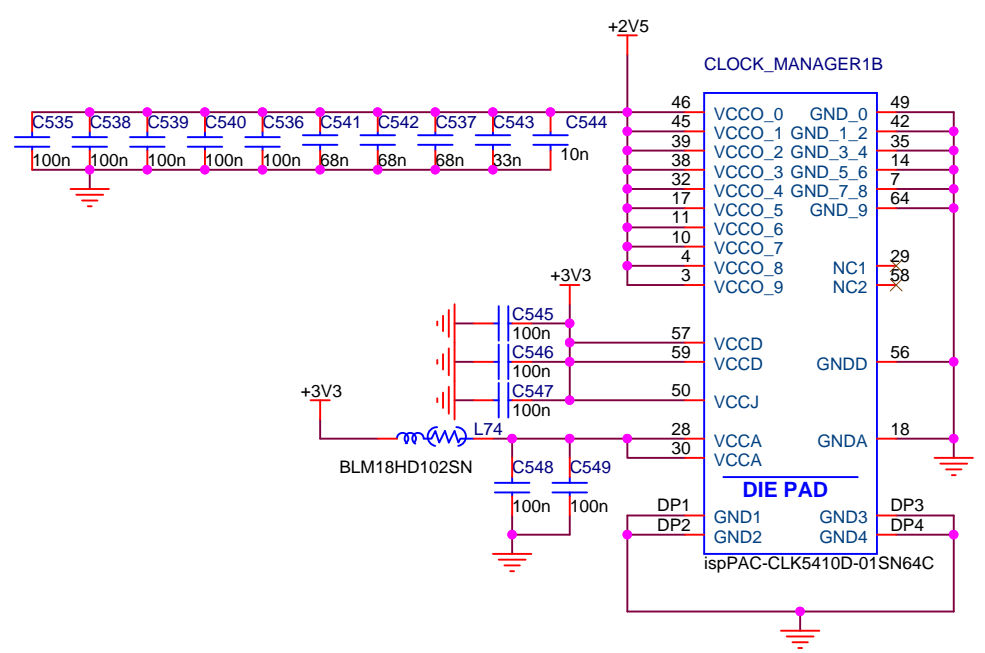
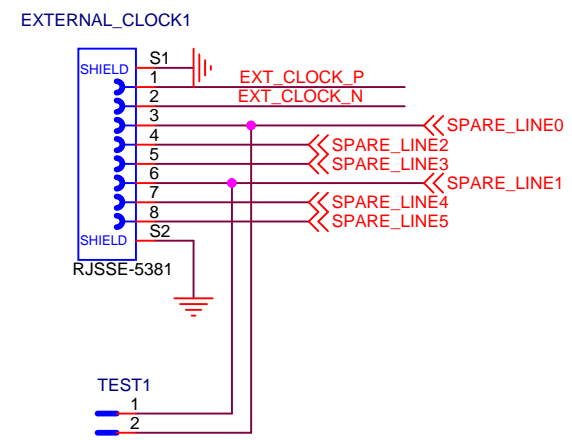
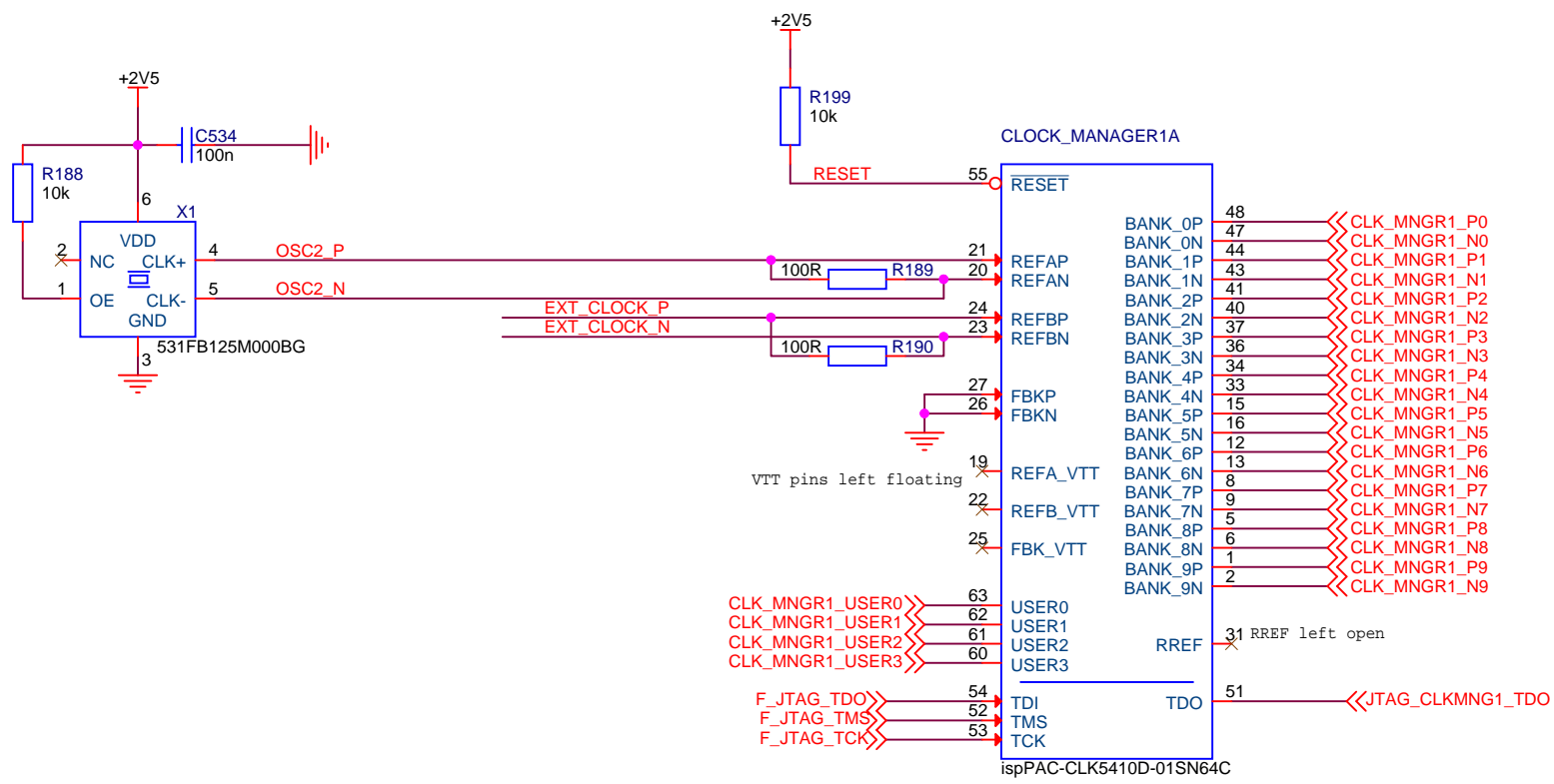

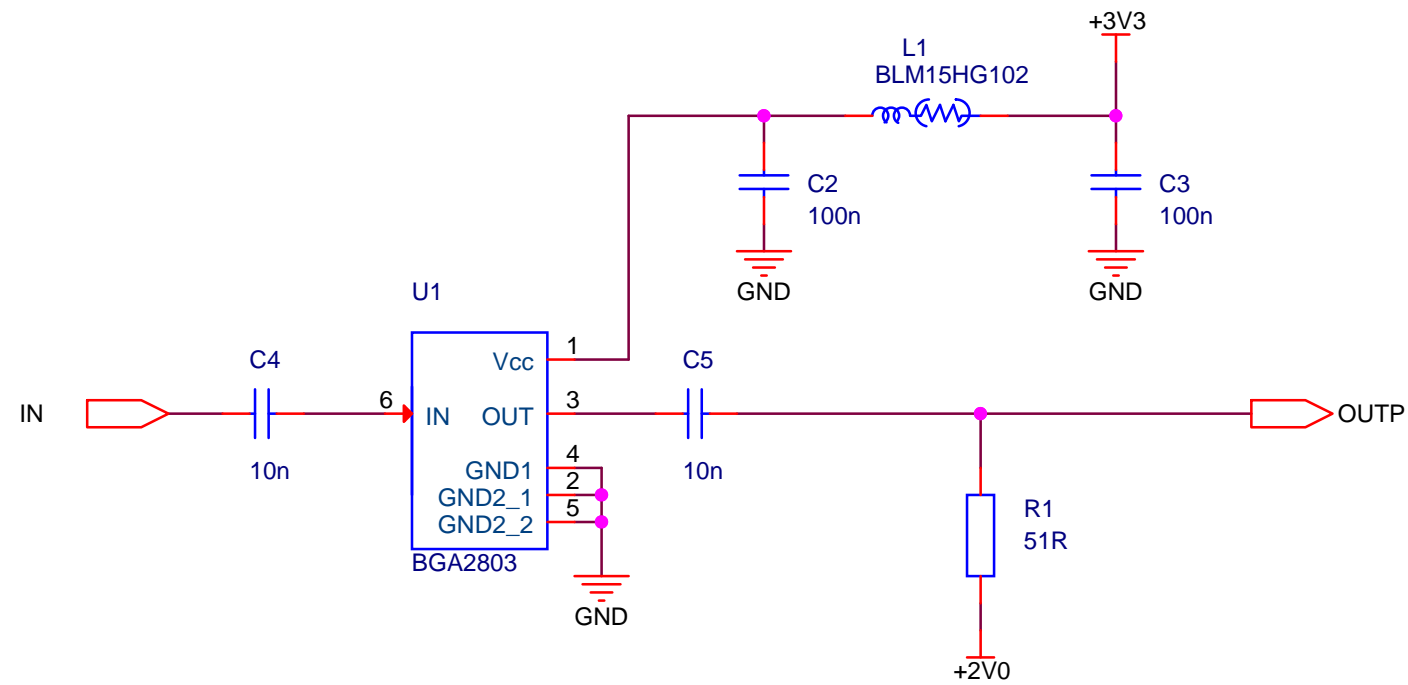

	Gesellschaft für Schwerionenforschung mbH Planckstrasse 1 D-64291 Darmstadt GERMANY <a href="http://www.gsi.de">www.gsi.de</a>	
	<h3>Channel_P</h3>	
Design: K:\GSIJOB\COME_AND_KISS\CBM-RICH-FEE\CBM-RICH-FEE1\CBM-RICH-FEE1		
Modified: Tuesday, April 03, 2012		Size: A4      Page: 8 / 71
Designer: M.Traxler		Layouter: S.Voltz

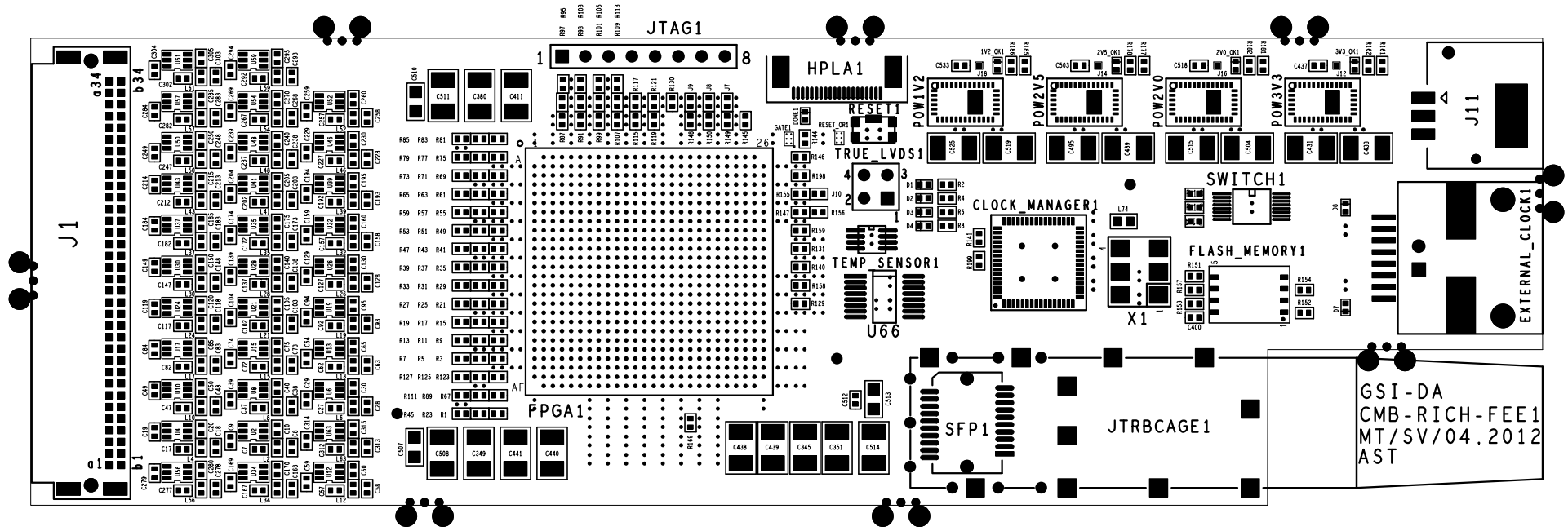

Jobname  
CBM-RICH-FEE1

Date  
04.2012

Designer  
M.Traxler

Layouter  
S.Voltz

Layer Nickname

Ast



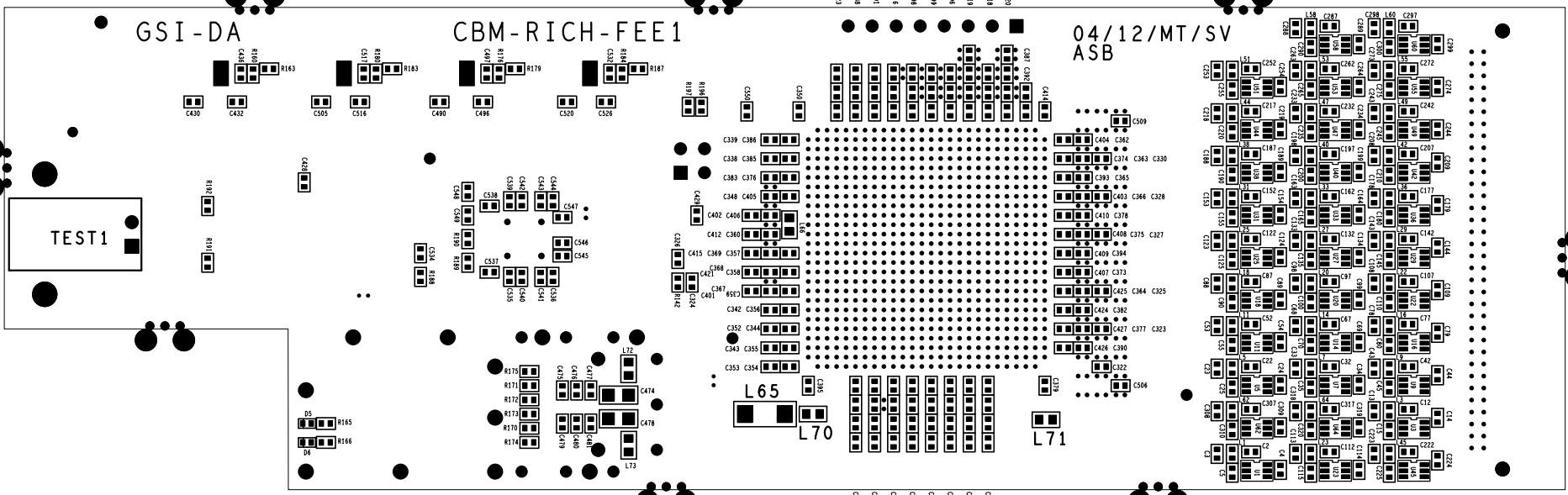

C301 8883 C304 C420  
 C302 C306 C418  
 C303 C309 C301 C421  
 C304 C306 C308  
 C305 C305 C309  
 C307 C307 C308  
 C308 C303 C418  
 C309 C301 C301  
 C310 C307 C308  
 C311 C402 C421

C403 C407 C408 C413  
 C402 C408 8893 C412  
 C401 C405 8893 C411  
 C400 C404 C408 C410  
 C402 C406 C408 C402  
 C403 C407 8893 C404  
 C405 C409 8893 C404

04/12/MT/SV  
 ASB

C201 C202 C203 C204 C205 C206 C207 C208 C209 C210 C211 C212 C213 C214 C215 C216 C217 C218 C219 C220 C221 C222 C223 C224 C225 C226 C227 C228 C229 C230 C231 C232 C233 C234 C235 C236 C237 C238 C239 C240 C241 C242 C243 C244 C245 C246 C247 C248 C249 C250 C251 C252 C253 C254 C255 C256 C257 C258 C259 C260 C261 C262 C263 C264 C265 C266 C267 C268 C269 C270 C271 C272 C273 C274 C275 C276 C277 C278 C279 C280 C281 C282 C283 C284 C285 C286 C287 C288 C289 C290 C291 C292 C293 C294 C295 C296 C297 C298 C299 C300 C301 C302 C303 C304 C305 C306 C307 C308 C309 C310 C311 C312 C313 C314 C315 C316 C317 C318 C319 C320 C321 C322 C323 C324 C325 C326 C327 C328 C329 C330 C331 C332 C333 C334 C335 C336 C337 C338 C339 C340 C341 C342 C343 C344 C345 C346 C347 C348 C349 C350 C351 C352 C353 C354 C355 C356 C357 C358 C359 C360 C361 C362 C363 C364 C365 C366 C367 C368 C369 C370 C371 C372 C373 C374 C375 C376 C377 C378 C379 C380 C381 C382 C383 C384 C385 C386 C387 C388 C389 C390 C391 C392 C393 C394 C395 C396 C397 C398 C399 C400 C401 C402 C403 C404 C405 C406 C407 C408 C409 C410 C411 C412 C413 C414 C415 C416 C417 C418 C419 C420 C421 C422 C423 C424 C425 C426 C427 C428 C429 C430 C431 C432 C433 C434 C435 C436 C437 C438 C439 C440 C441 C442 C443 C444 C445 C446 C447 C448 C449 C450 C451 C452 C453 C454 C455 C456 C457 C458 C459 C460 C461 C462 C463 C464 C465 C466 C467 C468 C469 C470 C471 C472 C473 C474 C475 C476 C477 C478 C479 C480 C481 C482 C483 C484 C485 C486 C487 C488 C489 C490 C491 C492 C493 C494 C495 C496 C497 C498 C499 C500

Asp

Layer Name

CBM-RICH-FEE1

Date 04.2015

Designer M.Trautler

Layouter S.Voltz

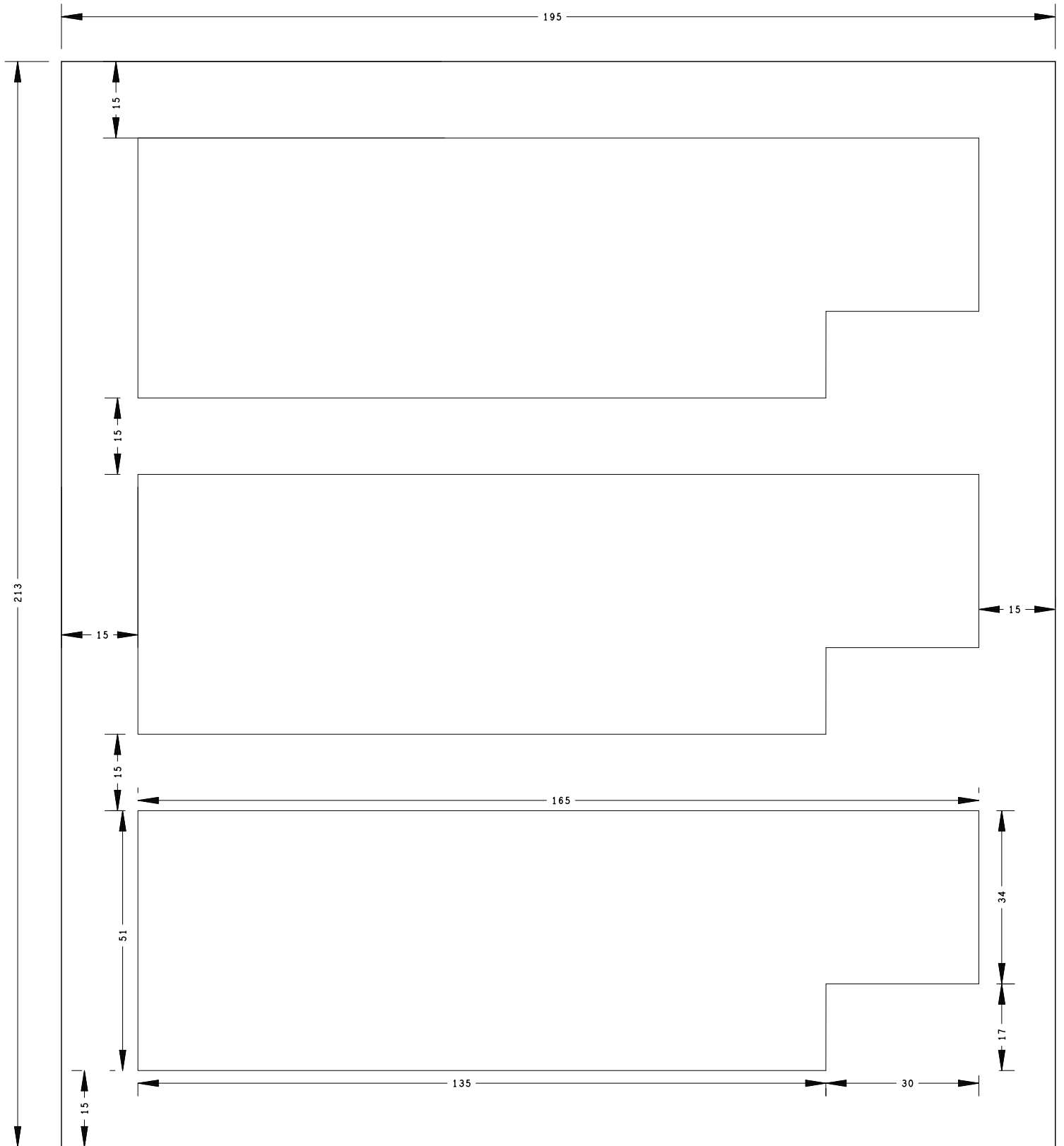

Jobname	Date	Designer	Layouter
CBM-RICH-FEE1	04.2012	M.Traxler	S.Voltz

Layer Nickname

Fab

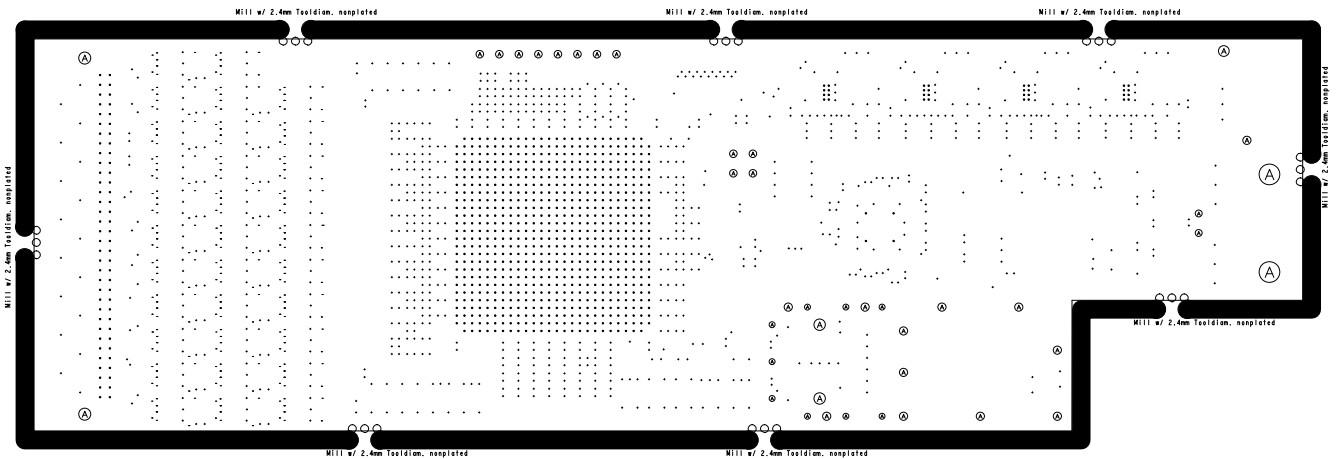

DRILL CHART: TOP to BOTTOM

ALL UNITS ARE IN MILLIMETERS

FIGURE	SIZE	PLATED	QTY
.	0.2	PLATED	776
.	0.2	PLATED	1008
◦	0.4	PLATED	1
⊙	0.8	PLATED	9
⊙	0.9	PLATED	2
⊙	1.0	PLATED	12
⊙	1.1	PLATED	11
○	1.0	NON-PLATED	24
⊙	1.1	NON-PLATED	1
⊙	1.4	NON-PLATED	1
⊙	1.5	NON-PLATED	2
⊙	1.6	NON-PLATED	2
○	2.4	NON-PLATED	16
Ⓐ	2.7	NON-PLATED	2

TOTAL HOLES: 1867



Jobname                      Date                      Designer                      Layouter  
 CBM-RICH-FEE1              04.2012                      M.Traxler                      S.Voltz

Layer Nickname                      Drd

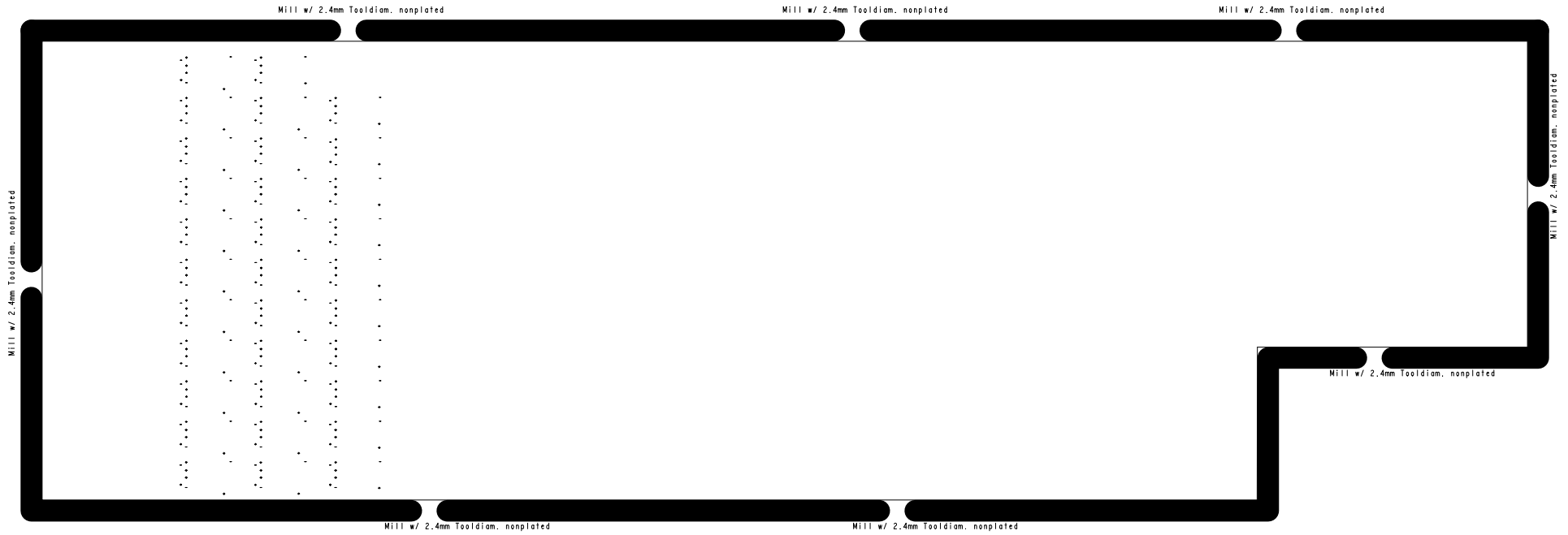

DRILL CHART: TOP to INNER1			
ALL UNITS ARE IN MILLIMETERS			
FIGURE	SIZE	PLATED	QTY
.	0.2	PLATED	160

TOTAL HOLES: 160

Jobname  
CBM-RICH-FEE1

Date  
04.2012

Designer  
M.Traxler

Layouter  
S.Voltz

Layer Nickname

Drd

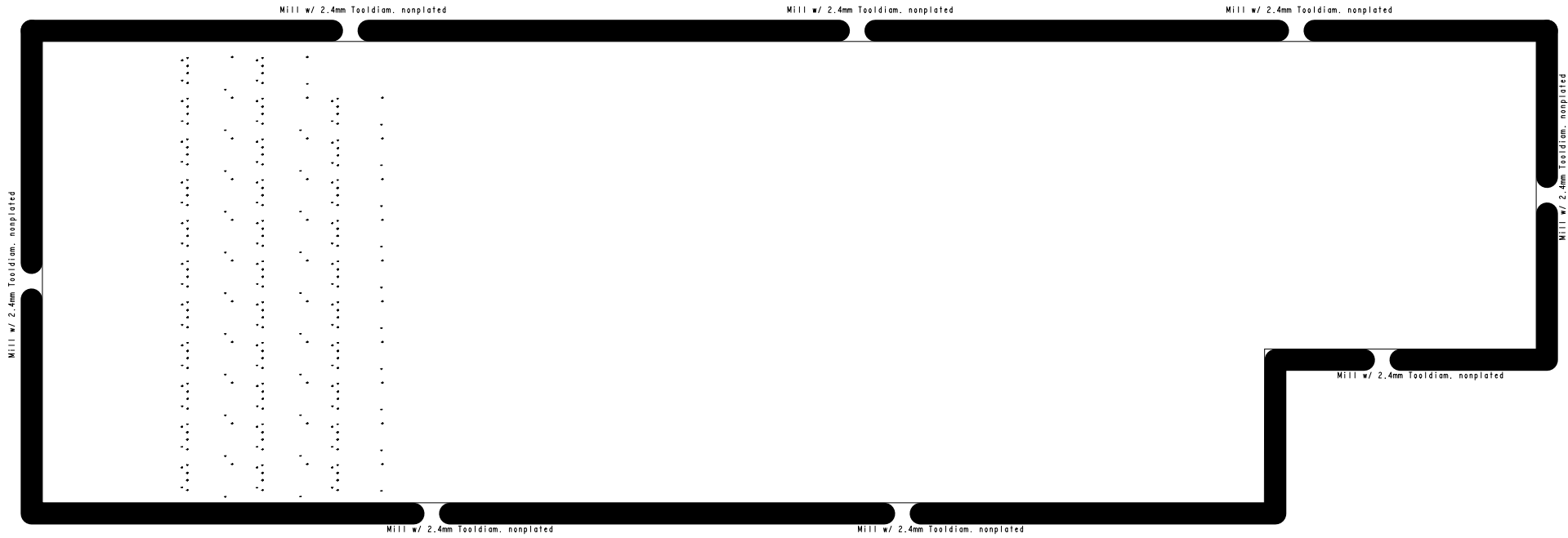

DRILL CHART: INNER10 to BOTTOM			
ALL UNITS ARE IN MILLIMETERS			
FIGURE	SIZE	PLATED	QTY
.	0.2	PLATED	160
TOTAL HOLES:			160

Jobname  
CBM-RICH-FEE1

Date  
04.2012

Designer  
M.Traxler

Layouter  
S.Voltz

Layer Nickname

Drd

# TOP- Signals

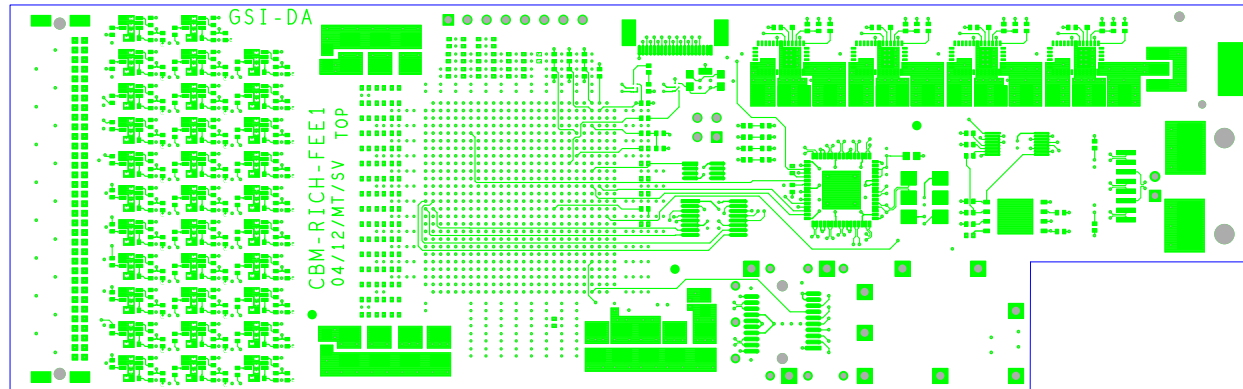

Jobname	Date	Designer	Layouter
CBM-RICH-FEE1	04.2012	M.Traxler	S.Voltz

name



IN1- GND-Plane, Planes: +1.2V VCCA

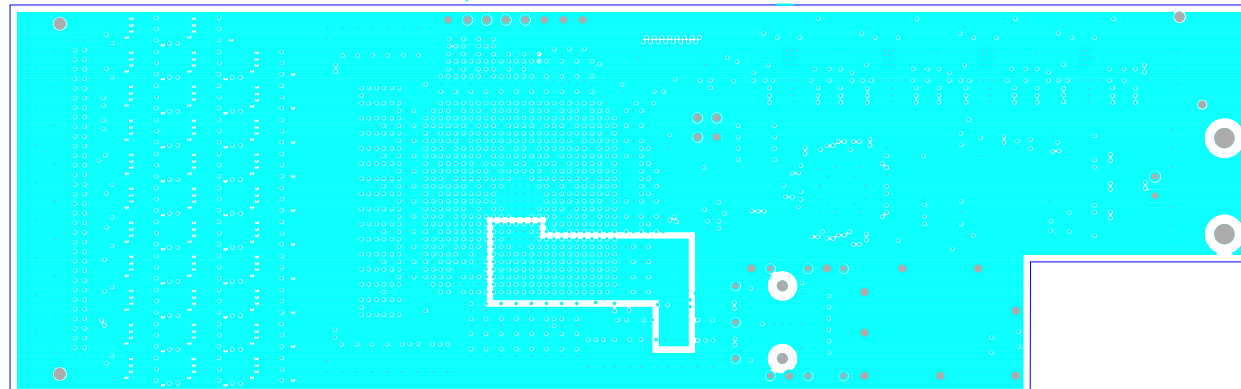

Jobname	Date	Designer	Layouter
CBM-RICH-FEE1	04.2012	M.Traxler	S.Voltz

name

# IN2- 500hm single ended, Diff. Pairs

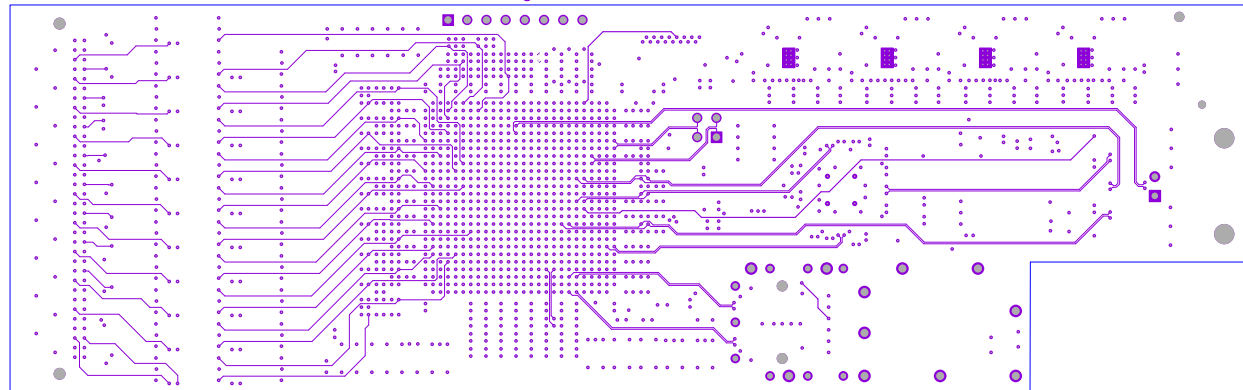

Jobname	Date	Designer	Layouter
CBM-RICH-FEE1	04.2012	M.Traxler	S.Voltz

name

IN3- Planes: +3V3,+1.2V\_lo\_L, +1.2V\_lo\_R

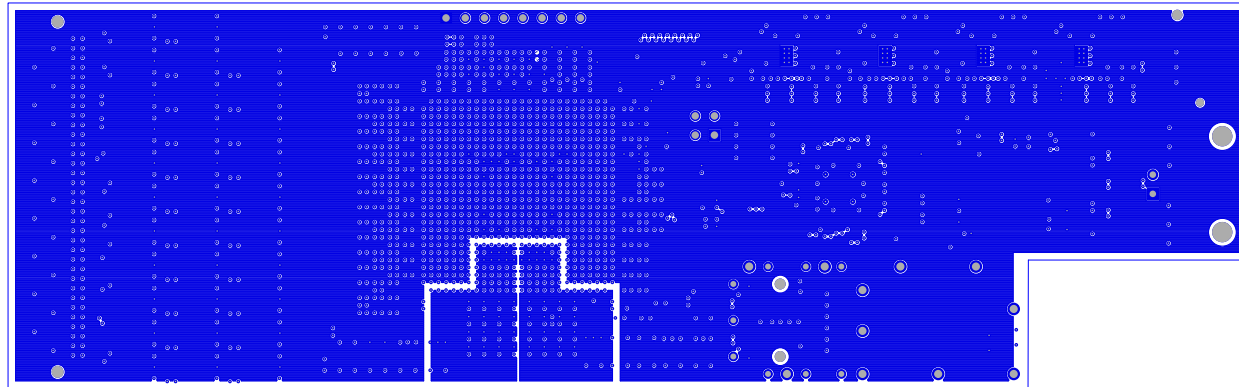

Jobname	Date	Designer	Layouter
CBM-RICH-FEE1	04.2012	M.Traxler	S.Voltz

name

IN4- 500hm single ended, Diff. Pairs

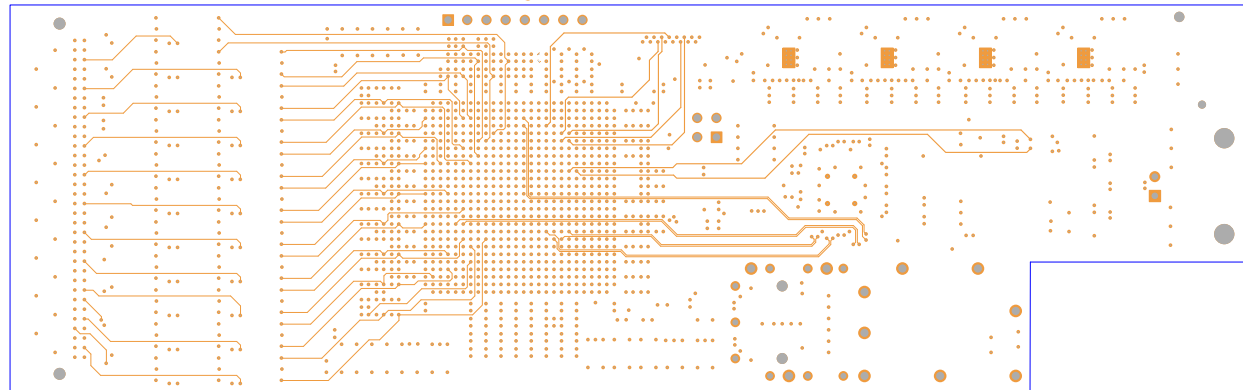

Jobname	Date	Designer	Layouter
CBM-RICH-FEE1	04.2012	M.Traxler	S.Voltz

n ame

## IN5- GND-Plane

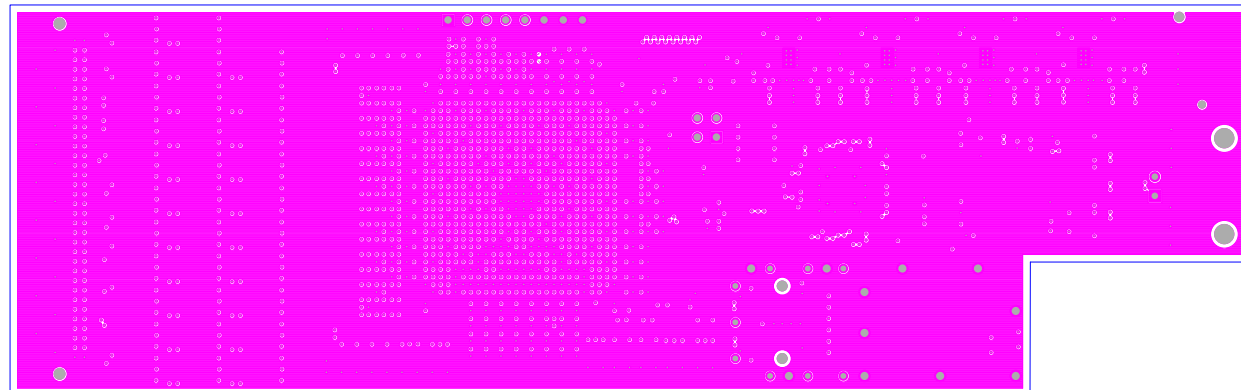

Jobname	Date	Designer	Layouter
CBM-RICH-FEE1	04.2012	M.Traxler	S.Voltz
name			

IN6- Planes: +2V0,+2V5

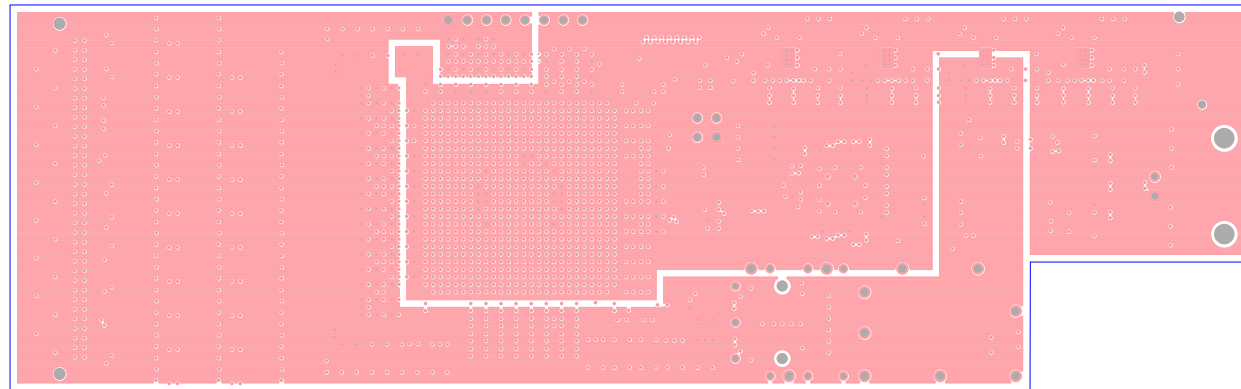

Jobname	Date	Designer	Layouter
CBM-RICH-FEE1	04.2012	M.Traxler	S.Voltz

n  
a  
m  
e



IN7- 500hm single ended, Diff. Pairs

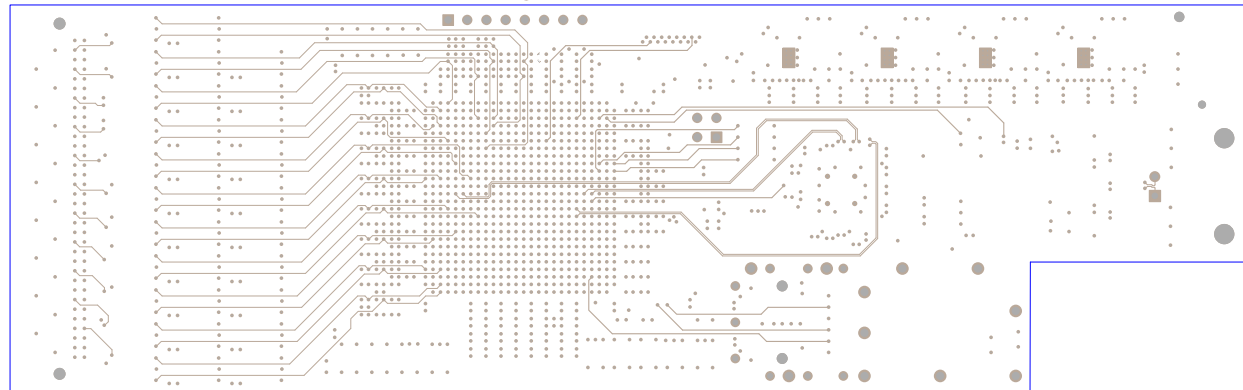

Jobname	Date	Designer	Layouter
CBM-RICH-FEE1	04.2012	M.Traxler	S.Voltz

n a m e

IN8- Planes: +1V2,+6V,GND

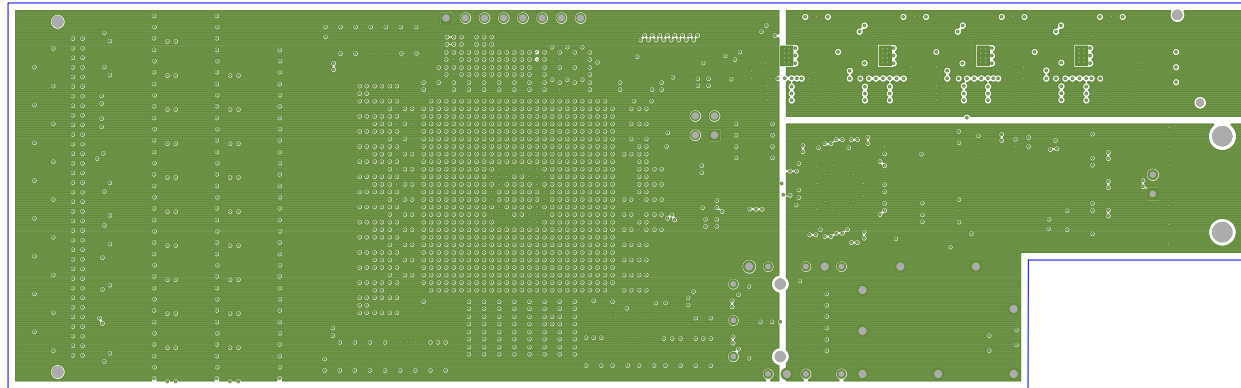

Jobname  
CBM-RICH-FEE1

Date  
04.2012

Designer  
M.Traxler

Layouter  
S.Voltz

name

IN9- 500hm single ended, Diff. Pairs

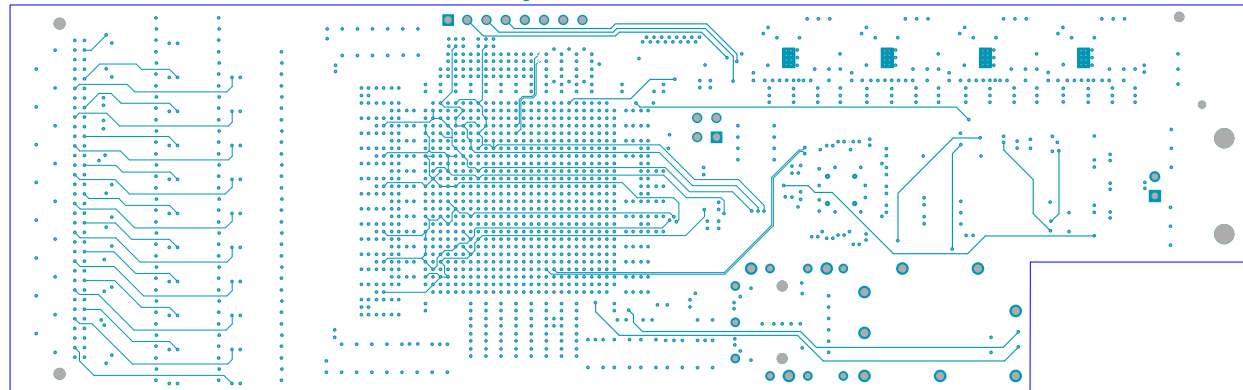

Jobname	Date	Designer	Layouter
CBM-RICH-FEE1	04.2012	M.Traxler	S.Voltz

n ame

# IN10- GND-Plane, +3.3V\_PLL

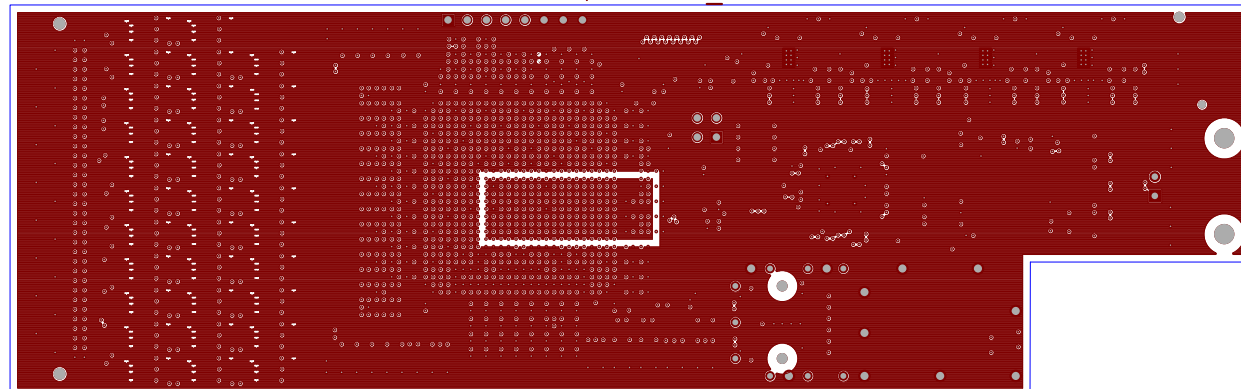

Jobname	Date	Designer	Layouter
CBM-RICH-FEE1	04.2012	M.Traxler	S.Voltz

name

# BOT- Signals

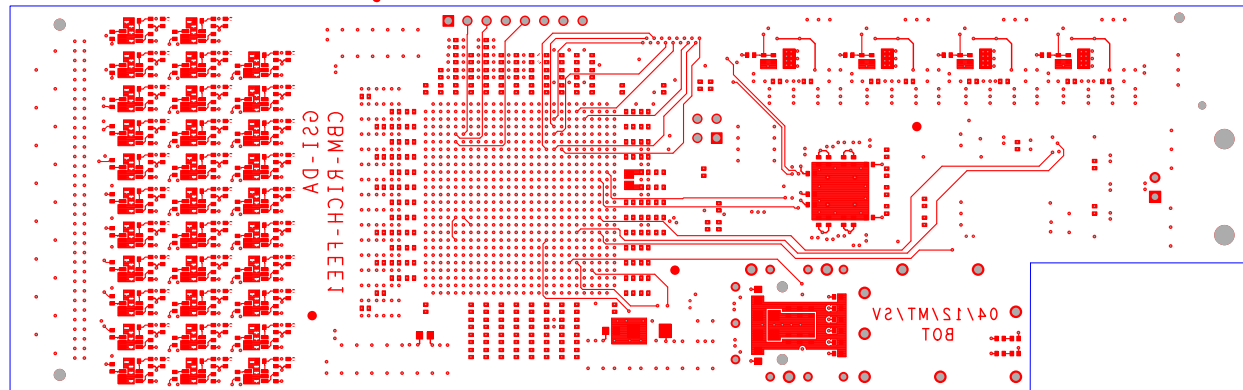

Jobname	Date	Designer	Layouter
CBM-RICH-FEE1	04.2012	M.Traxler	S.Voltz

name

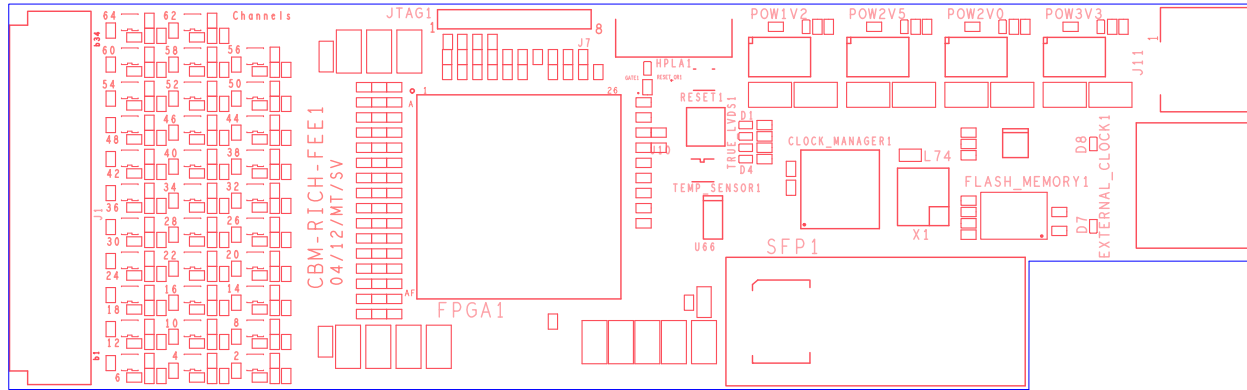

<b>Jobname</b>	<b>Date</b>	<b>Designer</b>	<b>Layouter</b>
CBM-RICH-FEE1	04.2012	M.Traxler	S.Voltz

Layer Nickname

Sst



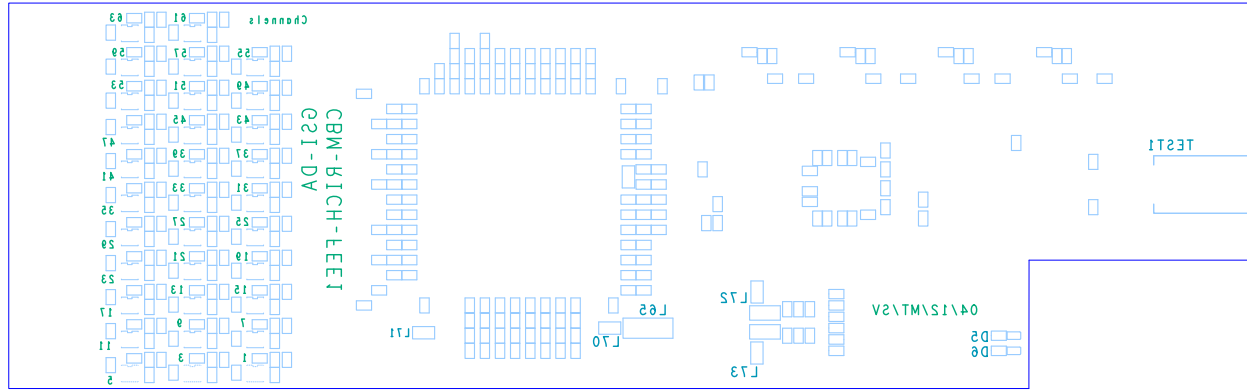

	Jobname	Date	Designer	Layouter
	CBM-RICH-FEE1	04.2012	M.Traxler	S.Voltz
Layer	Nickname			
	Ssb			

Material (µm)

Stack up

File

Assembly

25 Galvanic Cu  
 12 Copper  
 75 NP-155F-B  
 64 NP-155F-B  
 17 Copper  
 200 NP-155F-TL  
 17 Copper  
 64 NP-155F-B  
 64 NP-155F-B  
 17 Copper  
 200 NP-155F-TL  
 17 Copper  
 64 NP-155F-B  
 64 NP-155F-B  
 17 Copper  
 100 NP-155F-TL  
 17 Copper  
 64 NP-155F-B  
 64 NP-155F-B  
 17 Copper  
 200 NP-155F-TL  
 17 Copper  
 64 NP-155F-B  
 64 NP-155F-B  
 17 Copper  
 200 NP-155F-TL  
 17 Copper  
 64 NP-155F-B  
 75 NP-155F-B  
 12 Copper  
 25 Galvanic Cu

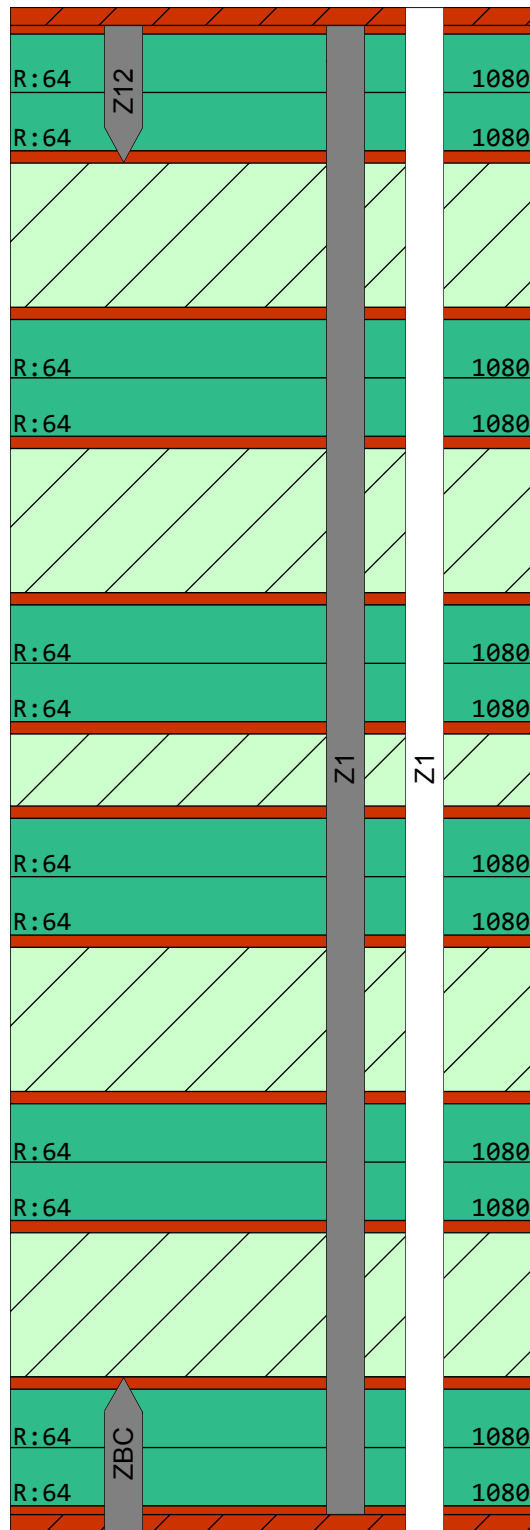

BS

I2

I3

I4

I5

I6

I7

I8

I9

I10

I11

LS

A1

Pressed thickness 1.88 mm

Date 28.03.2012  
 Generated by gbiernat

## i3

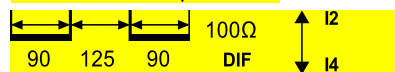
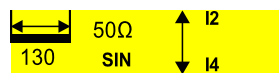

## i5

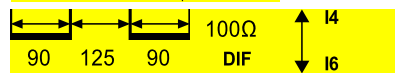
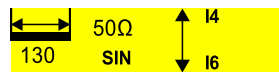

## i8

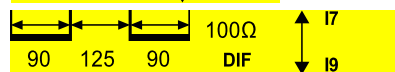
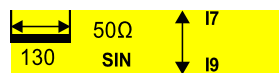

## 10

